



# INDUSTRY CATALOG



**Started in 1954 by a young Silvio Bonomi, Bonomi Industries Srl led product and process innovations of the brass valve industry for over 70 years**

**Our founder's motto was "Quality and trust". This is the legacy we bring forward every day.**







# About us

Bonomi Industries Srl is an Italian manufacturer of high quality shut-off brass valves, actuators and custom-engineered solutions. Under the RuB brand, its products are globally trusted for their reliability and performance in a variety of applications.

Bonomi Industries Srl is part of Hadron group — a private holding company established in 2018 during the strategic reorganization of Rubinetterie Utensilerie Bonomi (RuB), which also led to the creation of Shedstone, a real estate company — Bonomi Industries Srl continues to grow and innovate. Started in 1954, with entrepreneurial roots tracing back to 1828, the company upholds the values and tradition of a family business while embracing a vision focused towards the future.

Growth at Bonomi Industries Srl is driven by continuous investments in product improvements, advanced machining, assembly, and logistics technologies, as well as expanded manufacturing capabilities, enhanced system interconnectivity, database analysis and strengthened engineering and R&D efforts. At the same time, sustainability — encompassing environmental, social, and governance topics — has always been part of the company's DNA and inspires meaningful actions.

For Bonomi Industries Srl, innovation and responsibility go hand in hand. This commitment shapes a journey aimed at safeguarding the environment, empowering people, and fostering resilient governance for a better tomorrow.



**Bonomi Industries Srl turns words into actions for all stakeholders**  
Scan the QR code to discover our values



# Companies

*RuB* valves and actuators are trusted worldwide, installed across five continents and proven in the most demanding applications.

Production takes place entirely at our headquarters, Bonomi Industries Srl, in Mazzano (Brescia), Italy. Finished products are then distributed globally from Italy and through our international branches. In North America, *RuB, Incorporated* operates from a modern 5.000 sqm (50,000 sqf) facility, handling both assembly and distribution. In Japan, *RuB kk* serves as a strategic presence in a peculiar market.

With a strong global presence, we provide proximity, reliability, and outstanding service to our customers. Our sales team builds lasting partnerships with distributors and OEMs by offering responsive support and technical expertise. Certified, high-quality products, combined with deep knowledge of local cultures and regulations, make Bonomi Industries Srl the trusted partner in fluid control solutions.



**Bonomi Industries srl**

MAZZANO, BS - ITALY  
Manufacturing



**RuB, Inc.**

SHAKOPEE, MN - USA  
Distribution



**RuB KK**

TOKYO - JAPAN  
Distribution



**RuB, Inc.**  
SHAKOPEE, MN - USA  
Distribution



**Bonomi Industries Srl**  
MAZZANO, BS - ITALY  
Manufacturing



**RuB KK**  
TOKYO - JAPAN  
Distribution



# Quality

*Quality you can trust, proven through generations of experience.*

From rigorous incoming goods inspections to double leak testing, 24-72 hour valve assessments, and visual inspections for top markets/applications, Bonomi Industries Srl ensures consistent reliability and precision in every product. Advanced traceability systems, calibrated instruments, and statistical software enhance quality control throughout the production process.

Our dedicated Quality Control team supports continuous monitoring and improvement, ensuring that each production batch meets exactly applicable standards. Paired with robust testing protocols and expert technical support, we deliver solutions designed to meet the most challenging applications.



#### Approved by Lloyd's Register Quality Assurance:

ISO 9001:2015 (Quality Management) since 1998.  
ISO 14001:2018 (Environmental Management System) since 2021.  
ISO 45001:2018 (Occupational Health & Safety) since 2021.



**Environment:** Air and water are filtered and recovered. Use of recycled environment-friendly packaging materials. Scrap is recycled.



**Product Quality Assessment:** recognized by certifying bodies in all major industrialized countries worldwide



**Safety:** compliance with the provisions of decree 81/2008 for the safety system, extensive staff training, and continuous monitoring



**Customized products** developed by the Engineering Center



In compliance with the **PED Directive** since 2002



**Quality you can trust**

See our quality process in action/Experience every step of our quality process







# Sustainability

Sustainability has always been a necessity, not a choice. The adoption of sustainable practices at corporate level lays the foundation for creating virtuous cycles that inspire future generations.

Our commitment is stronger than ever, and we're proud to share with you here below figures that mark the tasks we focus on our actions, achievements, and the vision we have for the future. Localized production of electricity is now a reality and we have not been shy with our investments towards clean renewable energy.

Companies are finally waking up to producing their own electricity. Aside from covering the needs of our production manufacturing facility with through solar panels, we constantly reduce energy consumption by investing in smart technology and minimizing heavy material handling.

The diligence with which we strive to make our process and products less impactful on the environment is confirmed by the certifications awarded by international bodies, in particular ISO 14001:2018 and the "silver" medal in the EcoVadis sustainability assessment.

## HOW WE WALK THE TALK.

**100%** of our brass ball valves prevent unnecessary waste – lifetime guaranteed

**96%** manufacturing scrap is reused

**30%** of energy comes from our own renewable sources

**100%** cooling waters are recovered and reused



**Together, safeguarding our Planet**  
Learn more about our initiatives.







# OEM

Every year, OEMs all over the world rely on RuB custom solutions to reduce leaks, equipment breakages and production downtime. We're heavily invested in OEM customizations with custom-made machinery for innovative products and solutions.

We have proven expertise in solving technical and operational challenges for leading boilers, heat pumps and burners manufacturers, LPG gas tank and system manufacturers, manufacturers of watering systems, fire protection, refrigeration, HVAC manufacturers, marine applications with shipbuilders, compressors, tanks, machine tools manufacturers, filtration, chemical, food processing and pharmaceutical companies.

We are intrigued to learn about your obstacles and bring your custom, top shelf solution to life.

## PRIVATE LABEL

We strive to meet the needs of our customers in every way possible. And we do so not only through specifically designed, engineered and manufactured OEM products, but also by customizing standard RuB ball valves.

The possible branding options to choose from include:

- Changing the lever marking to the customer's trademark
- Packing with a custom label
- Customized handle colors and materials
- Customized valve fittings
- Dedicated valve body stamping
- Special marking on the valve body
- Custom installation instructions



**OEM solutions, custom made for you**

OEMs have a Partner to solve their challenges and develop new products





# Certifications

We are proud to offer 100% made-in-Italy shut-off brass valves, actuators, and OEM-engineered products, all manufactured in our ISO 9001:2015 certified headquarters in Brescia, Italy. Since adopting this quality management system in 1992 under Lloyd's Register, we have continuously improved product reliability, performance and traceability.

Our certifications, granted by leading global laboratories and agencies, demonstrate compliance with the highest standards for major applications and markets. Supported by rigorous testing and state of art technology, our products meet the demanding requirements of top manufacturers and distributors worldwide.

## PRODUCT TYPE APPROVALS

 Deutsche Vereinigung des Gas und Wasserfaches e.V. Technisch-wissenschaftlicher Verein		 General Directorate of Civil Defence	
 Deutsche Vereinigung des Gas und Wasserfaches		 The Australian Gas Association	
 Deutsche Vereinigung des Gas und Wasserfaches Hygiene		 OSHA Compliant	
 Schweizerischer Verein des Gas und Wasserfaches		 Factory Mutual Research Corporation	
 Attestation de Conformité Sanitaire		 Underwriter Laboratories Inc.	
 ARGB-KVBG		 CRN-TSSA	
 Water Regulations Advisory Scheme		 CSA International for Drinking Water to NSF/ANSI 61- NSF/ANSI 372	
 British Standards Institution		 CSA - Canadian Standards Association	
 Kiwa KUKreg4		 KSF - Kuwait Fire Service Directorate	
 Ri.se. / Boverket		 LIA - L.P Gas Instruments Inspections Association	
 Kiwa - Swedcert			

## COMPLIANCES

 ROHS		 PED 2014/68/UE by ICIM (0425)	<b>PED</b>
 Reach declaration	<b>Reach</b>	 Декларация соответствия	<b>EAC</b>



We developed and constantly innovate strict protocols and processes  
Discover all the certifications and awards received from international bodies



PATENTED  
NO. 1421306

OPEN  
SHUT

# RuB valve features

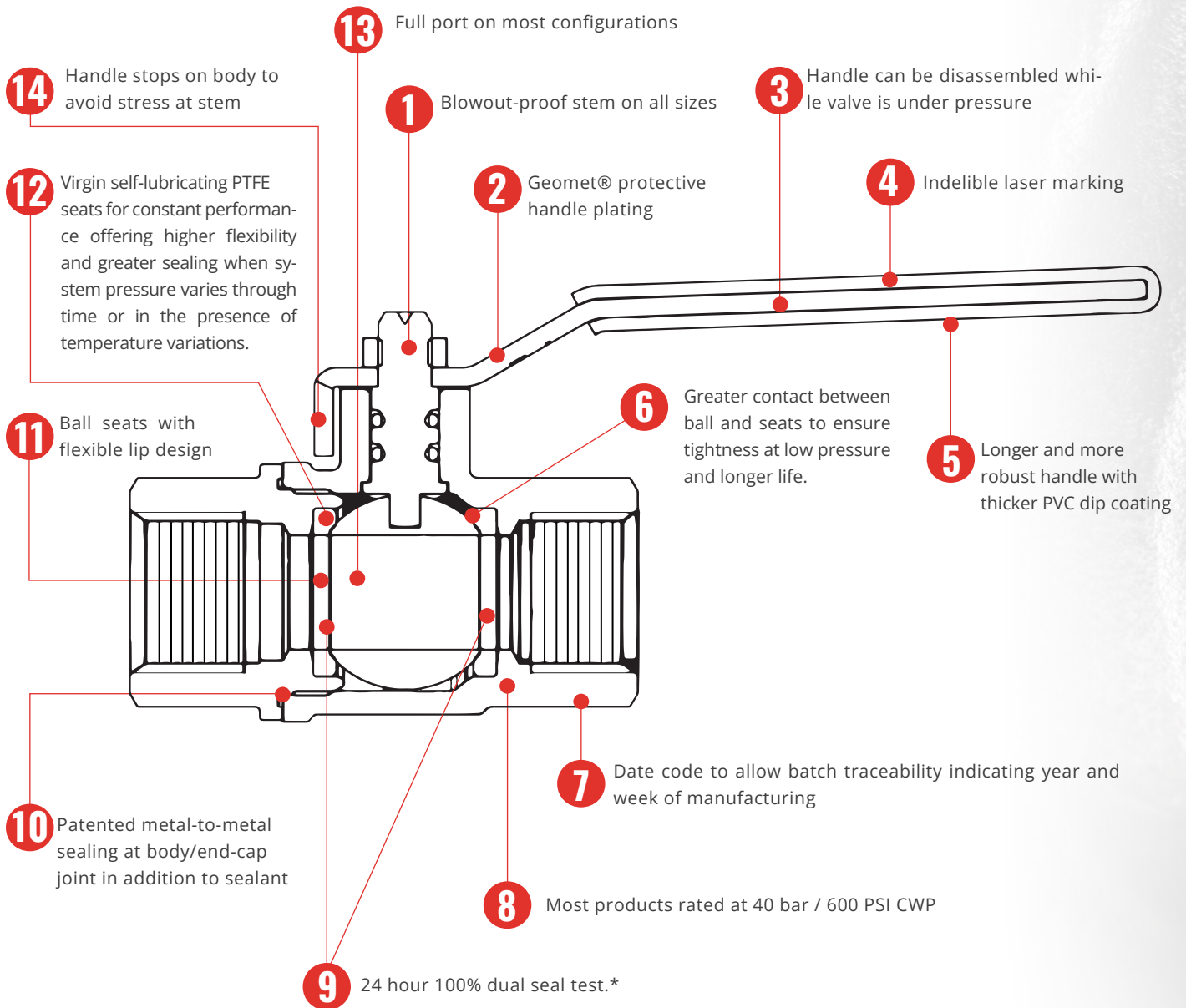

## RuB seal test

Valve in half open position is pressurized at 6 bar (87 psig), then closed, trapping compressed air in between ball seats and stem sealing. After adequate preset time, based upon valve size, any leaks are verified using extremely accurate electronic sensors and any defective valve is automatically rejected; all valves passing this initial seal test are filled with compressed air again and remain closed and under pressure for minimum 24 hours; after 24 hours, the valves go back again under the same accurate a new set of electronic pressure sensors and any leaking valve is automatically rejected.

\* Certain products are not suitable for double seal test



Our solutions come with an added benefit: maximizing your revenue  
Scan the QR code to discover our products





# INDUSTRY

From automotive and food processing to chemical, pharmaceutical, and power generation sectors, RuB valves are designed to meet the toughest operational demands. Our thorough 24-72 hour double-testing process ensures consistent performance, minimizing downtime and protecting your systems. Choose RuB for solutions that keep your operations running smoothly and efficiently, even in the most challenging environments.



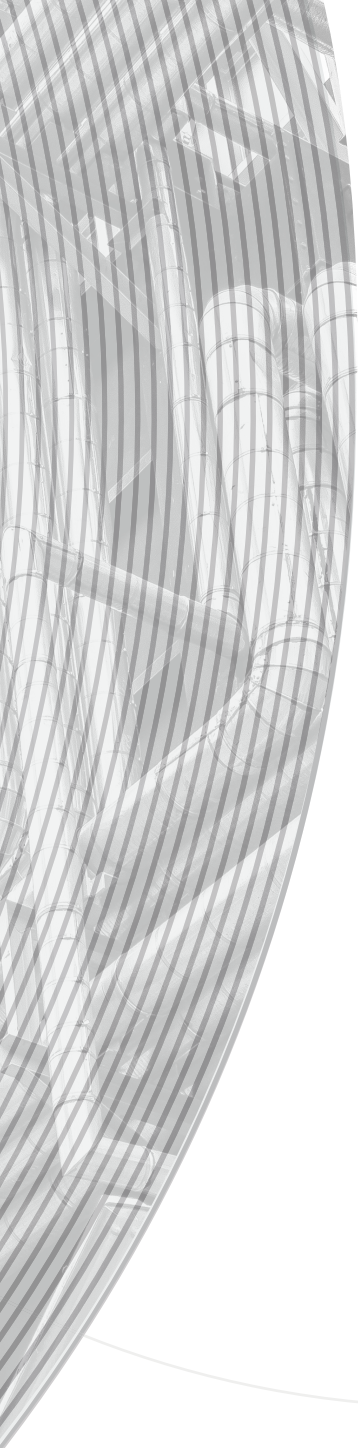

INDUSTRY  
Scan the QR code to discover our products



<b>s.17</b> motor-oil drain ball valve	Page 20
<b>s.33</b> 1/4" - 2" EN 10226-1, heavy duty packing gland	Page 22
<b>s.33 M/F</b> 1/4" - 2" EN 10226-1, heavy duty packing gland	Page 24
<b>k.60</b> spring return 1/4" - 2", heavy duty - DIN 16722 M3, EN 10226-1	Page 26
<b>s.7200L 3-way, lever, 4 seats, L-port (diverting)</b> 1/2" - 1", heavy duty	Page 28
<b>s.7241L 3-way, lever, 4 seats, L-port (diverting)</b> 1/2" - 1", heavy duty	Page 30
<b>s.7300L 3-way, lever, 4 seats, T-port</b> 1/4" - 2" EN 10226-1	Page 32
<b>s.7341L NPT 3-way, lever, 4 seats, T-port</b> 1/2" - 2" ISO 5211	Page 36
<b>s.7350L BSPT 3-way, lever, 4 seats, T-port</b> 1/2" - 2" ISO 7/1, BS21	Page 40
<b>s.7600L 3-way, lever, 2 seats, L-port (diverting)</b> 1/4" - 2" EN 10226-1	Page 44
<b>s.7641L NPT 3-way, lever, 2 seats, L-port (diverting)</b> 1/2" - 2" ISO 5211	Page 46
<b>s.7650L BSPT 3-way, lever, 2 seats, L-port (diverting)</b> 1/2" - 2" ISO 7/1, BS21	Page 48
<b>s.84</b> EN331 spring return 1/4" - 2" EN 10226-1	Page 50
<b>s.85</b> 1/4" - 2" EN 10226-1, packing gland	Page 52
<b>s.92</b> barrel drain 3/4" - 1"	Page 54
<b>s.92S</b> NPT solid ball 1/4" - 4"	Page 56
<b>s.92</b> NPT SS trim 1/4" - 2"	Page 58
<b>s.95</b> NPT spring return 1/4" - 2"	Page 60
<b>s.100</b> 3-way 4 seats T-port 1/4" - 2" ISO 228	Page 62
<b>s.101</b> 3-way 4 seats L-port 1/4" - 2" ISO 228	Page 64
<b>s.172</b> motor-oil compact drain ball valve	Page 66
<b>SNI7352</b> 1/4" NPT needle valve	Page 68
<b>Instrumentation package</b>	Page 70



## s.17 motor-oil drain ball valve

Specifically responding to a need in the automotive application, s.17 is fitted under the oil sump to ease drainage operations, and furthermore granting a most reliable tightness thanks to its special automatic locking device, even under severe conditions of vibration stress.

Frozen drain plug and stripped threads are eliminated, no more contact with hot oil, no messy hands or cloths and reduced oil changing time.



### QUALITY

- 24h 100% seal test guaranteed
- No metal-to-metal moving parts
- No maintenance ever required
- Handle clearly shows ball position
- Silicone-free lubricant on all seals
- Dual sealing system to prevent leakage
- Handle stops on body to avoid stresses at stem

### BODY

- Hot forged sand blasted, unplated brass body and cap sealed with Loctite® or equivalent thread sealant
- Compact design and solid structure
- Fines brass according to EN 12165 and EN 12164 to prevent corrosion

### STEM

- Blowout-proof unplated brass stem
- Maintenance-free, double FPM O-ring at the stem for maximum safety

### SEALING

- Glass filled pure PTFE self-lubricating seats with flexible-lip design

### THREADS

- M24x1.5 – 3/8" threads

### HANDLE

- Tamper proof and sealed to prevent dirt or dust from entering the rotation mechanism
- 90° opening rotation
- Automatic lock in closed position, to prevent accidental opening and thus warrant utmost safety

### OPTIONS

- M16x1.5 threads – hose connection
- M12x1.5 threads – hose connection
- M24x1.5 – 1/4" threads



### WORKING PRESSURE & TEMPERATURE

- 20 bar (300 PSI) non-shock cold working pressure
- -20°C to +130°C (-4°F to +266°F)
- **WARNING:** freezing of the fluid in the installation may severely damage the valve

### UPON REQUEST

- Stainless steel ball (1.4401 / AISI 316)
- Custom design

### PED DIRECTIVE

- The product meets the requirements of PED Directive 2014/68/UE and according to art.4 par.3, it does not require CE marking

### APPROVED BY OR IN COMPLIANCE WITH

- EAC – Declaration of conformity (Russia, Kazakhstan, Belarus)
- RoHS Compliant (EU)
- **NOTE:** approvals apply to specific configurations/sizes only.

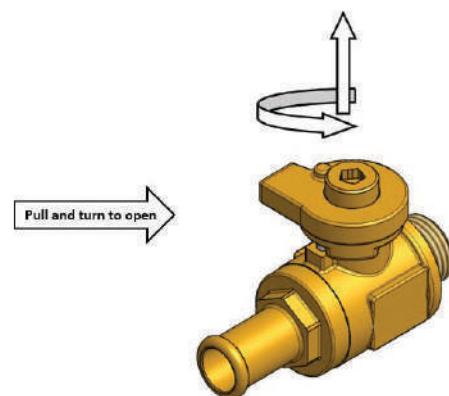

## s.17 XCES17 - 5813

Each user should perform his own tests to find out the suitability for his particular application. BONOMI INDUSTRIES makes no warranty, express or implied, as to the shape, fit or function of a product for any application. Contact us or consult with your supplier for additional information on the suitability of the BONOMI INDUSTRIES products with your specific field of use.



INDUSTRY

Part description		Q.ty	Material
1	Unplated sand blasted body	1	CW617N
2	Seat	2	PTFE glass filled 5-15%
3	Chrome plated ball	1	CW617N
4	Unplated end-cap - hose connection - custom	1	CW617N
5	Unplated stem O-ring design	1	CW617N
6	Unplated sand blasted handle	1	CW617N
7	Unplated handle cap	1	CW617N
8	Spring	1	X10CrNi 18-8
9	Spring pin $\varnothing$ 3x8 ISO 8752	2	X10CrNi 18-8
10	O-Ring	1	FPM

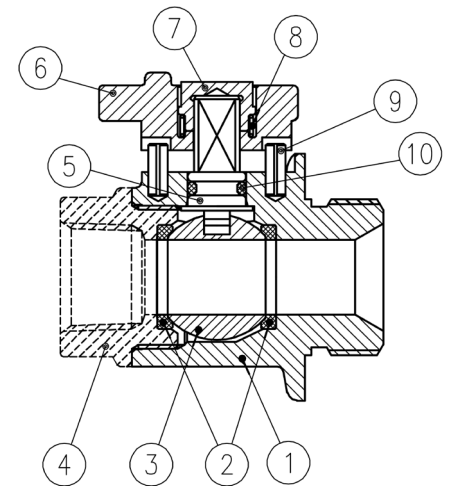

D (mm)	M12X1.5	M16X1.5	M24X1.5
DN (mm)	6	10	11.5
I (mm)	10	10	12
B (mm)	27	27	38
G (mm)	24.5	24.5	25.5
A (mm)	31.5	31.5	31.5
H (mm)	18	18	18
A/F (mm)	25	25	27
Kv (m <sup>3</sup> /h)		8.8	

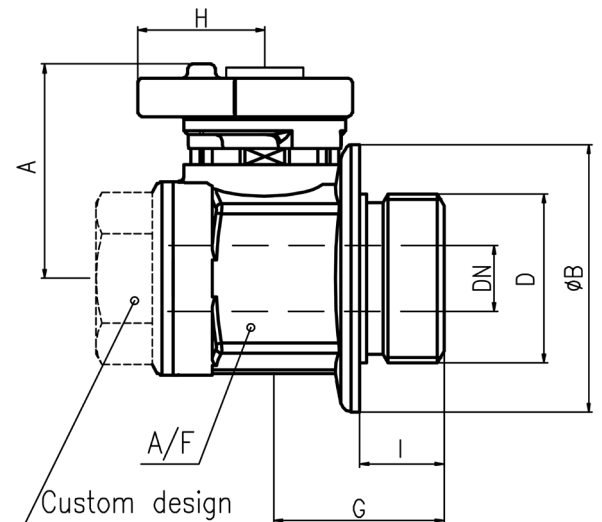

### PRESSURE-TEMPERATURE CHART

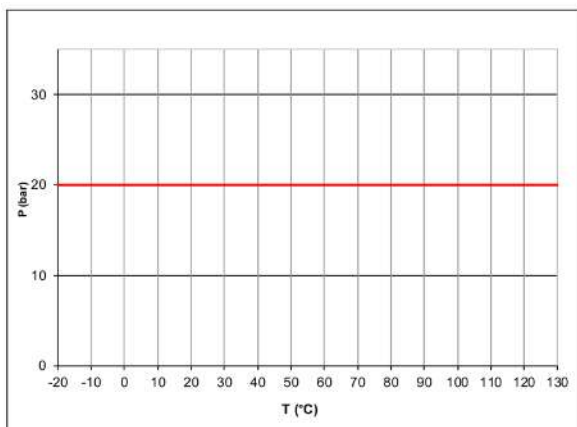

### PRESSURE DROP CHART

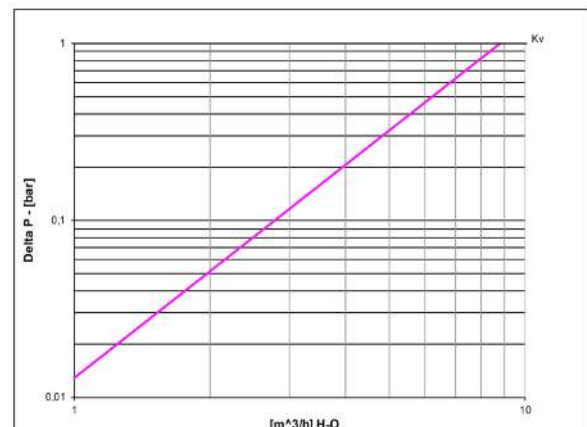



# s.33

Female/Female  
1/4" - 2"

EN 10226-1, heavy duty, packing gland



## QUALITY

- 24h 100% seal test guaranteed
- Dual sealing system allows valve to be operated in either direction making installation easier
- No metal-to-metal moving parts
- No maintenance ever required
- Handle clearly shows ball position
- Silicone-free lubricant on all seals
- Chrome plated brass ball for longer life
- Handle stops on body to avoid stresses at stem

## BODY

- Hot forged sand blasted, nickel plated brass body and cap sealed with Loctite® or equivalent threads sealant
- Finest brass according to EN 12165 and EN 12164 specifications

## STEM

- Blowout-proof nickel plated brass stem
- Pure PTFE adjustable packing gland and reinforced washer for lower torque and easy maintenance

## SEALING

- Pure PTFE self-lubricating seats with flexible-lip design

## THREADS

- EN 10226-1, ISO 228 parallel female by female threads

## FLOW

- 100 % full port for maximum flow

## HANDLE

- Geomet® carbon steel handle with thick PVC dip coating. Handle coating offers both thermal and electrical protection
- **WARNING:** do not exceed reasonable temperature and/or electrical load

## WORKING PRESSURE & TEMPERATURE

- 65 bar (940 PSI) up to 1", 40 bar (600 PSI) over 1" non- shock cold working pressure
- -40°C to +170°C (-40°F to +350°F)
- **WARNING:** freezing of the fluid in the installation may severely damage the valve

## UPON REQUEST

- Stainless steel ball and/or stem (1.4401 / AISI 316)
- Glass filled PTFE seals
- Custom design

## PED DIRECTIVE

- According to 2014/68/UE module A: it cannot be used with dangerous gases in sizes larger than 25mm

## APPROVED BY OR IN COMPLIANCE WITH

- RoHS Compliant (EU)
- EAC – Declaration of conformity (Russia, Kazakhstan, Belarus)

**NOTE:** approvals apply to specific configurations/sizes only.

## OPTIONS

- Oval lockable handle **1**
- Patented locking device **2**
- Stainless steel handle (1.4016 / AISI 430) **3**
- T-handle **4**

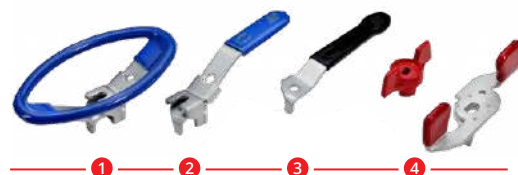

## s.33 XCES33 - 6012

Each user should perform his own tests to find out the suitability for his particular application. BONOMI INDUSTRIES makes no warranty, express or implied, as to the shape, fit or function of a product for any application. Contact us or consult with your supplier for additional information on the suitability of the BONOMI INDUSTRIES products with your specific field of use.



INDUSTRY

Part description	Q.ty	Material
1 Nickel plated body	1	CW617N
2 Seat	2	PTFE
3 Chrome plated ball	1	CW617N
4 Nickel plated end-cap	1	CW617N
5 Nickel plated stem packing gland design	1	CW617N
6 Nickel plated gland nut	1	CW617N
7 Geomet® nut	1	CB4FF (EN10263-2)
8 Packing gland seal	1	PTFE
9 Washer	1	PTFE carbon filled 25%
10 Black PVC coated Geomet® steel handle	1	DD11 (EN10111)

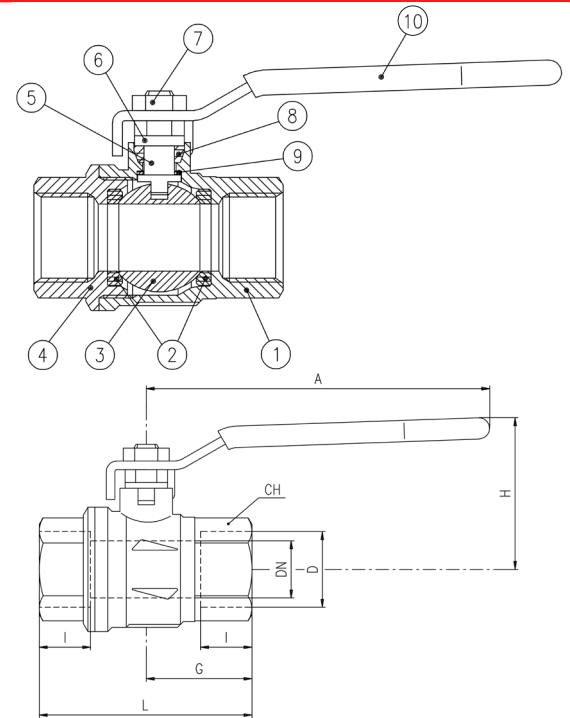

1 1/4"-2" hollow ball

Compliant to CE 2014/68/UE product  
Equipment category I Module A

Code	S33B00	S33C00	S33D00	S33E00	S33F00	S33G00	S33H00	S33I00
D (inch)	1/4"	3/8"	1/2"	3/4"	1"	1 1/4"	1 1/2"	2"
DN (mm)	8	10	15	20	25	32	40	50
I (mm)	14	14	16.5	19	22.5	25	26	29
L (mm)	51	51	61	74.5	90.5	104	117	135
G (mm)	25.5	25.5	30.5	37	45.5	52	59	67.5
A (mm)	82	82	100	120	120	158	158	158
H (mm)	39.5	39.5	43	52.5	56.5	78	85	91.5
CH (mm)	22	22	27	32	41	50	55	70
PN (Bar)	65	65	65	65	65	40	40	40
Kv (m3/h)	4.1	8.7	28	60	100	95	179	233

Ball valves are marked CE on handle from 1 1/4" to 2" as follow:  
CE XXCODEXX Cat I-A

### PRESSURE-TEMPERATURE CHART

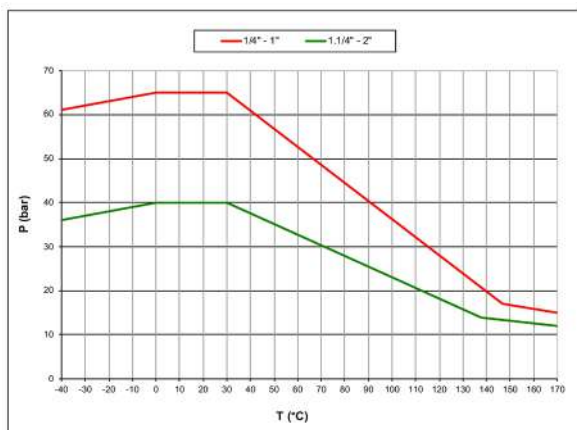

### PRESSURE DROP CHART

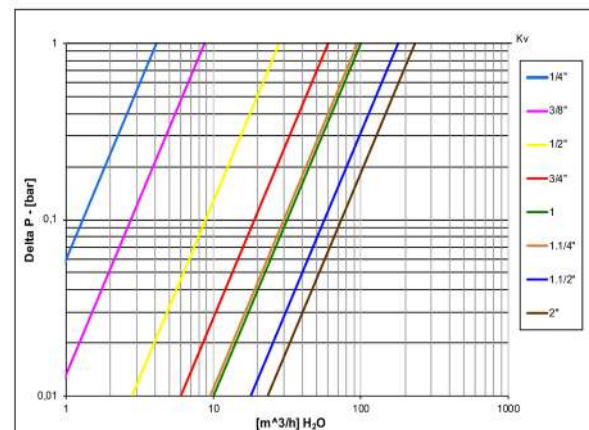



# s.33 M/F

Male/Female  
1/4" - 2"

EN 10226-1, heavy duty, packing gland



## QUALITY

- 24h 100% seal test guaranteed
- Dual sealing system allows valve to be operated in either direction making installation easier
- No metal-to-metal moving parts
- No maintenance ever required
- Handle clearly shows ball position
- Silicone-free lubricant on all seals
- Chrome plated brass ball for longer life
- Handle stops on body to avoid stresses at stem

## BODY

- Hot forged sand blasted, nickel plated brass body and cap sealed with Loctite® or equivalent threads sealant
- Finest brass according to EN 12165 and EN 12164 specifications

## STEM

- Blowout-proof nickel plated brass stem
- Pure PTFE adjustable packing gland and reinforced washer for lower torque and easy maintenance

## SEALING

- Pure PTFE self-lubricating seats with flexible-lip design

## THREADS

- EN 10226-1, ISO 228 parallel female thread by EN 10226-1 taper male thread

## FLOW

- 100 % full port for maximum flow

## HANDLE

- Geomet® carbon steel handle with thick PVC dip coating. Handle coating offers both thermal and electrical protection
- **WARNING:** do not exceed reasonable temperature and/or electrical load

## WORKING PRESSURE & TEMPERATURE

- 65 bar (940 PSI) up to 1", 40 bar (600 PSI) over 1" non- shock cold working pressure
- -40°C to +170°C (-40°F to +350°F)
- **WARNING:** freezing of the fluid in the installation may severely damage the valve

## UPON REQUEST

- Stainless steel ball and/or stem (1.4401 / AISI 316)
- Glass filled PTFE seals
- Custom design

## PED DIRECTIVE

- According to 2014/68/UE module A: it cannot be used with dangerous gases in sizes larger than 25mm

## APPROVED BY OR IN COMPLIANCE WITH

- RoHS Compliant (EU)
- EAC – Declaration of conformity (Russia, Kazakhstan, Belarus)

**NOTE:** approvals apply to specific configurations/sizes only.

## OPTIONS

- Oval lockable handle **1**
- Patented locking device **2**
- Stainless steel handle (1.4016 / AISI 430) **3**
- T-handle **4**

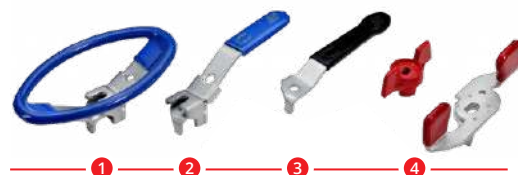



## s.33 M/F XCE3321 - 6012

Each user should perform his own tests to find out the suitability for his particular application. BONOMI INDUSTRIES makes no warranty, express or implied, as to the shape, fit or function of a product for any application. Contact us or consult with your supplier for additional information on the suitability of the BONOMI INDUSTRIES products with your specific field of use.



INDUSTRY

Part description	Q.ty	Material
1 Nickel plated body	1	CW617N
2 Seat	2	PTFE
3 Chrome plated ball	1	CW617N
4 Nickel plated male end-cap	1	CW617N
5 Nickel plated stem packing gland design	1	CW617N
6 Nickel plated gland nut	1	CW617N
7 Geomet® nut	1	CB4FF (EN10263-2)
8 Packing gland seal	1	PTFE
9 Washer	1	PTFE carbon filled 25%
10 Black PVC coated Geomet® steel handle	1	DD11 (EN10111)

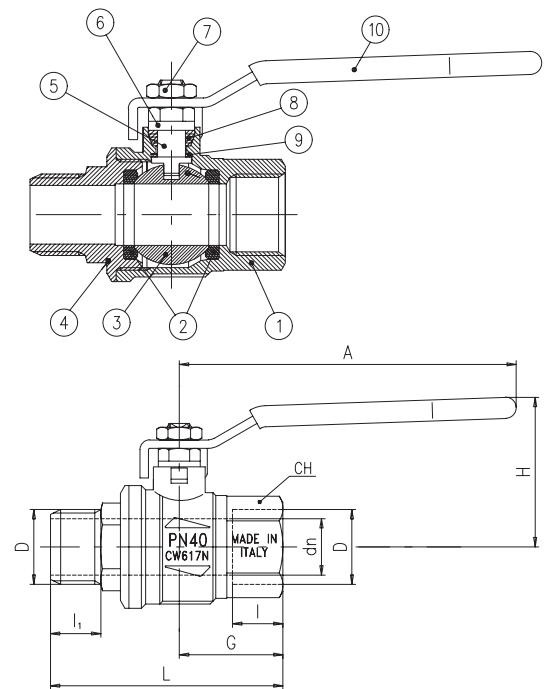

1 1/4"-2" hollow ball

Compliant to CE 2014/68/UE product  
Equipment category I Module A

Code	S33B20	S33C20	S33D20	S33E20	S33F20	S33G20	S33H20	S33I20
D (inch)	1/4"	3/8"	1/2"	3/4"	1"	1 1/4"	1 1/2"	2"
DN (mm)	8	10	15	20	25	32	40	50
I (mm)	14	14	16.5	19	22.5	25	26	29
I1 (mm)	13	13	16.5	18	22	24	24	27.5
L (mm)	62	62	72	83	99.5	112.5	127	143.5
G (mm)	25.5	25.5	30.5	37	45.5	52	59	67.5
A (mm)	82	82	100	120	120	158	158	158
H (mm)	39.5	39.5	43	52.5	56.5	78	85	91.5
CH (mm)	22	22	27	32	41	50	55	70
PN (Bar)	65	65	65	65	65	40	40	40
Kv (m3/h)	4.1	8.7	28	60	100	95	179	233

Ball valves are marked CE on handle from 1 1/4" to 2" as follow:  
CE XXCODEXX Cat I-A

### PRESSURE-TEMPERATURE CHART

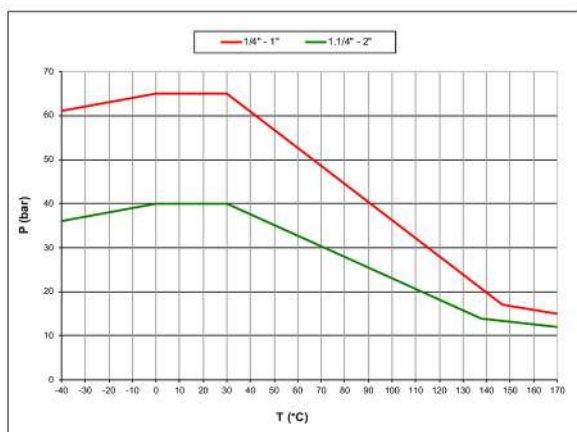

### PRESSURE DROP CHART

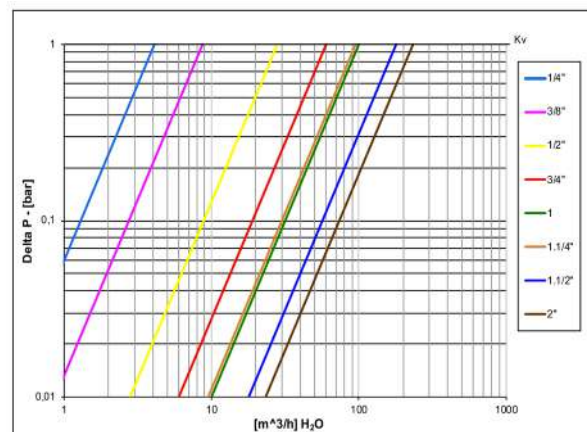



# k.60 spring return

**Female/Female  
1/4" - 2", heavy duty - DIN 16722 M3 EN 10226-1**



Access to fluid systems in public places could potentially convert into costs and safety problems. In order to avoid unattended valves being left open with negative economic or environmental consequences, **RuB** developed the automatic self-closing valve. The valve can be opened normally by rotating the handle 90° and when the user releases the handle, the valve shuts off automatically. Best solution for service stations, trucks, public areas, gardens. The same feature is useful in industrial applications, where a valve must not be left open unattended.

## HIGH TEMPERATURE RESISTANCE

Now approved for HTB use (Hochtemperaturbeständigkeit) - Class B 0,1 (0,1 bar @650°C for at least 30 minutes).



**H2 READY:** product approved in EU acc.to EN331 (sizes 1/4" to 2") for the 1st, 2nd and 3rd gas families, therefore compatible with hydrogen use up to 50% in the gas mixture, as established in the 1st gas family of the EN437 (ref. G110)



## QUALITY

- 24h 100% seal test guaranteed
- Dual sealing system allows valve to be operated in either direction making installation easier
- No metal-to-metal moving parts
- No maintenance ever required
- Handle clearly shows ball position
- Silicone-free lubricant on all seals
- Handle stops on body to avoid stresses at stem
- Chrome plated brass ball for longer life

## BODY

- Hot forged sand blasted, nickel plated brass body and cap sealed with Loctite® or equivalent thread sealant
- Valve length according to DIN 16722 M3 for sizes from 3/8" to 2" (DN10 to DN50). Size 1/4" (DN 8) complies to DIN 3202 M3.
- Finest brass according to EN 12165 and EN 12164 specifications

## STEM

- Blowout-proof nickel plated brass stem
- Maintenance-free, double FPM O-rings at the stem for maximum safety

## SEALING

- Pure PTFE self-lubricating seats with flexible-lip design

## THREADS

- EN 10226-1, ISO 228 parallel female by female threads

## FLOW

- 100% full port for maximum flow

## HANDLE

- Robust spring ensures auto shutt-off with max pressure in valve
- Geomet® carbon steel handle with thick PVC dip coating. Handle coating offers both thermal and electrical protection
- **WARNING:** do not exceed reasonable temperature and/or electrical load

## WORKING PRESSURE & TEMPERATURE

- 65 bar (940 PSI) up to 1", 40 bar (600 PSI) over 1" non-shock cold working pressure
- -20°C to +170°C (-4°F to +350°F)
- For use with dangerous fluids temperature rating is
- -20°C to +60°C (-4°F to +140°F) and pressure rating is
- 5 bar (72 PSI) / **HTB** Class B 0,1
- **WARNING:** freezing of the fluid in the installation may severely damage the valve

## UPON REQUEST

- Stainless steel ball (1.4401 / AISI 316)
- Custom design
- Stainless steel handle (1.4016 / AISI 430)

## PED DIRECTIVE

- Assessment according to Pressure Equipment Directive 2014/68/UE module B+D by ICIM (0425)

## APPROVED BY OR IN COMPLIANCE WITH

- DVGW (Germany) – MOP 5 B 0,1
- RoHS Compliant (EU)
- EAC – Declaration of conformity (Russia, Kazakhstan, Belarus)

**NOTE:** approvals apply to specific configurations/sizes only.

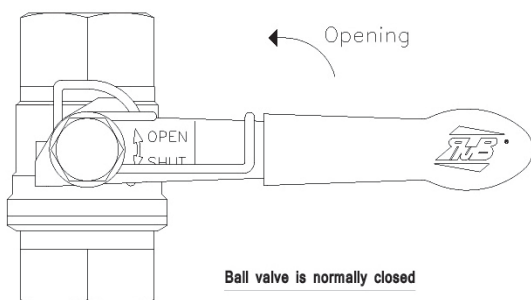

# k.60 spring return XCEK60MR - 5813

Each user should perform his own tests to find out the suitability for his particular application. BONOMI INDUSTRIES makes no warranty, express or implied, as to the shape, fit or function of a product for any application. Contact us or consult with your supplier for additional information on the suitability of the BONOMI INDUSTRIES products with your specific field of use.



Part description		Q.ty	Material
1	Nickel plated body	1	CW617N
2	Seat	2	PTFE
3	Chrome plated ball	1	CW617N
4	Nickel plated end-cap	1	CW617N
5	Nickel plated stem O-ring design	1	CW617N
6	Unplated spring nut	1	CW617N
7	O-Ring	2	FPM
8	Spring return	1	1.4310 (AISI 302)
9	Yellow PVC coated Geomet® steel handle	1	DC01

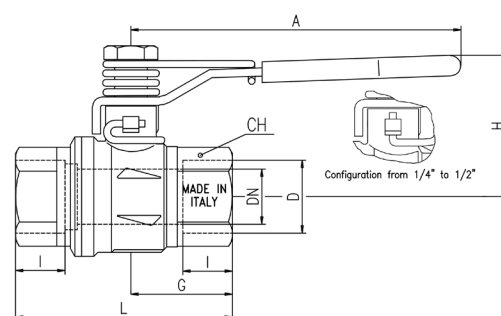
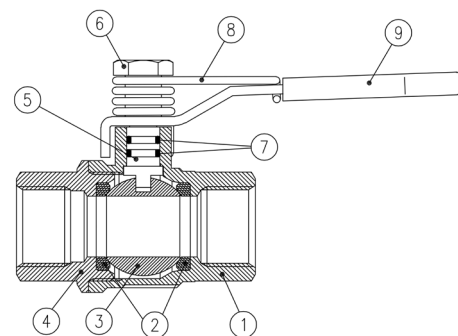

1 1/4"-2" hollow ball

Compliant to CE 2014/68/UE product Equipment category III Module B+D

Code	S60B05M	S60C05M	S60D05M	S60E05M	S60F05M	S60G05M	S60H05M	S60I05M
D (inch)	1/4"	3/8"	1/2"	3/4"	1"	1 1/4"	1 1/2"	2"
DN (mm)	8	10	15	20	25	32	40	50
I (mm)	14	14	16.5	19	22.5	25	26	29
L (mm)	50	60	75	80	90	110	120	140
G (mm)	25.5	25.5	30.5	37	45.5	52	59	67.5
A (mm)	100	100	100	120	120	158	158	158
H (mm)	40	40	43	51	55.5	75	81	88.5
CH (mm)	22	22	27	32	41	50	55	70
PN (bar)	65	65	65	65	65	40	40	40
Kv (m3/h)	4.1	8.7	28	60	100	95	179	233

Ball valves are marked CE on handle from 1 1/4" to 2" as follow: CE 0425 Cat IIIB+D PS: 5 GAS TS1: -20°C TS2: +60°C

## PRESSURE-TEMPERATURE CHART

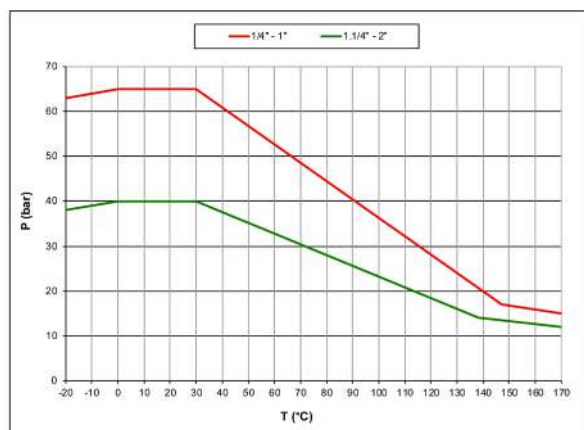

## PRESSURE DROP CHART

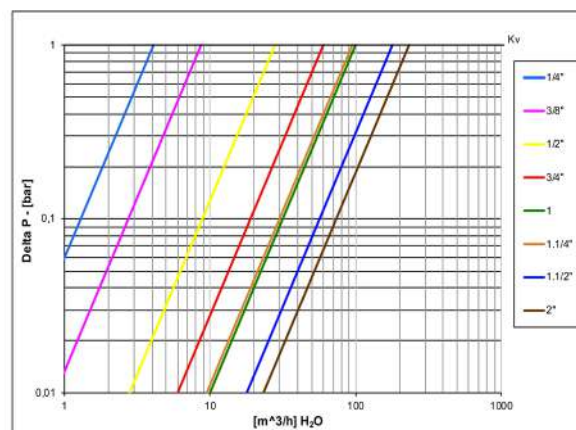



# s.7200L

## 3-way, lever, 4 seats, L-port (diverting)

**Female/Female/Female**  
**1/2" - 1"**  
**Heavy duty**

The RuB S.7200L is the right choice for fluid diversion and is designed with robust maintenance-free components ensuring ease of operation and safety. With a simple 90° turn of the handle, you can divert flow from one downstream outlet to the other. It combines traditional manual operation with modern automation. It is also very easy to convert from its sturdy lever handle to ISO 5211 actuator flange assembly. The valve can be purchased separately, with handle or with a RuB actuator already mounted.



### QUALITY

- Electronic 100% seal test guaranteed for maximum safety
- No metal-to-metal moving parts
- No maintenance ever required
- Silicone-free lubricant on all seals
- Chrome plated brass ball for longer life
- Each valve is seal tested for maximum safety
- Performs well in any orientation
- Strong configuration

### BODY

- Hot forged sand blasted, external nickel plated brass body and cap sealed with Loctite® or equivalent thread sealant
- Integrated ISO5211 / DIN3337 mounting flange for universal connection to actuator
- Finest brass according to EN 12165 and EN 12164 specifications
- 3-way L-port design for flow diversion

### STEM

- Blowout-proof nickel plated brass stem
- Maintenance-free, double FPM O-rings at the stem for maximum safety

### SEALING

- Pure PTFE self-lubricating seats with flexible-lip design
- Four seats design for mixing of various fluids in the system

### THREADS

- EN 10226-1, ISO 228 parallel female by female threads

### FLOW

- 100% full port for maximum flow

### HANDLE

- Geomet® carbon steel handle with thick PVC dip coating. Handle coating offers both thermal and electrical protection
- Handle removable with valve in service
- **WARNING:** do not exceed reasonable temperature and/or electrical load

### WORKING PRESSURE & TEMPERATURE

- 30 Bar up to 1", 20 bar over 1", non-shock cold working pressure
- -20°C to +170°C (-4°F to +350°F)
- **WARNING:** freezing of the fluid in the installation may severely damage the valve

### UPON REQUEST

- Custom design
- Stainless steel stem (1.4401 / AISI 316)
- Configurations with 4 seats, L-port (s.7200L) or T-port (s.7300L)

### PED DIRECTIVE

- The product meets the requirements of PED Directive 2014/68/UE and according to art.4 par.3, it does not require CE marking.

### APPROVED BY OR IN COMPLIANCE WITH

- RoHS Compliant (EU)
- EAC – Declaration of conformity (Russia – Kazakhstan – Belarus)

**NOTE:** approvals apply to specific configurations/sizes only.

S.72 3-WAY "L" PORT OPERATING POSITIONS

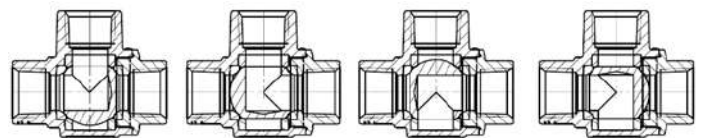

### OPTIONS

- Rack and pinion pneumatic actuator (spring return or double acting)
- S.7200 without handle, actuator ready
- Various actuator linkage kit



# s.7200L XGES7200L - 5941

Each user should perform his own tests to find out the suitability for his particular application. BONOMI INDUSTRIES makes no warranty, express or implied, as to the shape, fit or function of a product for any application. Contact us or consult with your supplier for additional information on the suitability of the BONOMI INDUSTRIES products with your specific field of use.



INDUSTRY

Part description		Q.ty	Material
1	Nickel plated body (External nickel plated, unplated inside)	1	CW617N
2	Seat	2	PTFE
3	Seat	2	PTFE
4	Chrome plated ball	1	CW617N
5	Nickel plated end-cap (External nickel plated, unplated inside)	1	CW617N
6	Washer	1	PTFE carbon filled 25%
7	Nickel plated stem O-ring design	1	CW617N
8	O-Ring	2	FPM
9	Screw handle stop	1	CW617N
10	Spring	1	1.4310 / AISI 302
11	Unplated spring bushing	1	CW617N
12	Stainless steel screw	1	1.4301 / AISI 304
13	Geomet® plated steel handle	1	DD11 (EN10111)
14	Black dipped coating	1	PVC

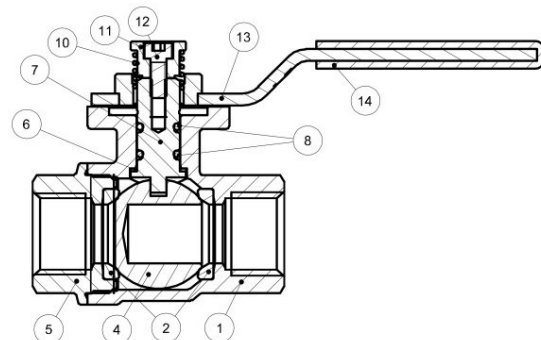

Code	S72D00L	S72E00L	S72F00L
Size (inch)	1/2"	3/4"	1"
DN (mm)	15	20	25
I (mm)	16.5	19	22.5
L (mm)	65	79	92.5
G (mm)	32.5	39.5	46.5
H (mm)	32.5	39.5	42.5
N (mm)	34.5	42	49.5
ØA (mm)	36	36	36
ØC (mm)	Ø5.2 (M6)	Ø5.2 (M6)	Ø5.2 (M6)
p (mm)	100	100	100
H1 (mm)	49	56	59
S (mm)	2.2	2.2	2.2
T (mm)	10	10	10
F (mm)	7.3	8.3	8.3
CH (mm)	27	32	41
Flange connection DIN ISO 522 DIN 3337	F03	F03	F03

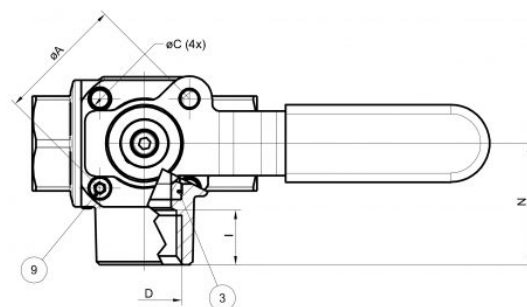
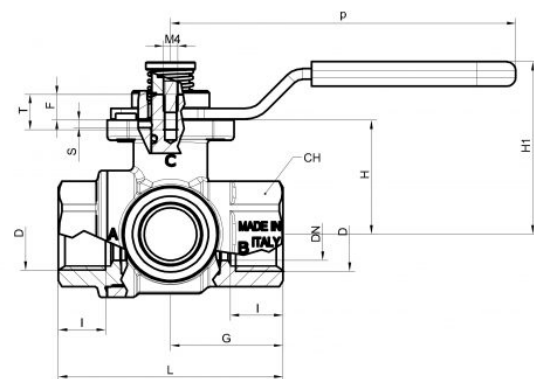

## TORQUE FOR ACTUATOR SIZING N.M

Delta P -->	0÷16 bar	
	to open	to close
1/2"	10.5	10.5
3/4"	13	13
1"	22	22

## TORQUE CORRECTION FACTORS

Valve torque can vary according to operating frequency, temperature and friction characteristics of the media.

If media has more or less friction than water, multiply torque by the following factors:

Lubricating oils or liquids	0.8
Dry gases, natural gas	1.5
Slurries or liquids bearing abrasive particles	1.5÷2.5



# s.7241L NPT

## 3-way, lever, 4 seats, L-port (diverting)

**Female/Female/Female**  
**1/2" - 1"**  
**Heavy duty**

The RuB S.7241L is the right choice for fluid diversion and is designed with robust maintenance-free components ensuring ease of operation and safety. With a simple 90° turn of the handle, you can divert flow from one downstream outlet to the other. It combines traditional manual operation with modern automation.

It is also very easy to convert from its sturdy lever handle to ISO 5211 actuator flange assembly.

The valve can be purchased separately, with handle or with a RuB actuator already mounted.



### QUALITY

- Electronic 100% seal test guaranteed for maximum safety
- No metal-to-metal moving parts
- No maintenance ever required
- Silicone-free lubricant on all seals
- Chrome plated brass ball for longer life
- Each valve is seal tested for maximum safety
- Performs well in any orientation
- Strong configuration

### BODY

- Hot forged sand blasted, external nickel plated brass body and cap sealed with Loctite® or equivalent thread sealant
- Integrated ISO5211 / DIN3337 mounting flange for universal connection to actuator
- Finest brass according to EN 12165 and EN 12164 specifications
- 3-way L-port design for flow diversion

### STEM

- Blowout-proof nickel plated brass stem
- Maintenance-free, double FPM O-rings at the stem for maximum safety

### SEALING

- Pure PTFE self-lubricating seats with flexible-lip design
- Four seats design for mixing of various fluids in the system

### THREADS

- NPT taper ANSI B.1.20.1 female by female threads

### FLOW

- 100% full port for maximum flow

### HANDLE

- Geomet® carbon steel handle with thick PVC dip coating. Handle coating offers both thermal and electrical protection
- Handle removable with valve in service
- **WARNING:** do not exceed reasonable temperature and/or electrical load

### WORKING PRESSURE & TEMPERATURE

- 300 PSI non-shock cold working pressure
- -4°F to +302°F (-20°C to +150°C)
- **WARNING:** freezing of the fluid in the installation may severely damage the valve

### UPON REQUEST

- Custom design
- Stainless steel stem (1.4401/ AISI 316)
- Configurations with 4 seats & T-port (s.7341L) or 2 seats & L-port (s.7641L)

### APPROVED BY OR IN COMPLIANCE WITH

- RoHS Compliant (EU)
- EAC – Declaration of conformity (Russia, Kazakhstan, Belarus)

**NOTE:** approvals apply to specific configurations/sizes only.

S.72 3-WAY "L" PORT OPERATING POSITIONS

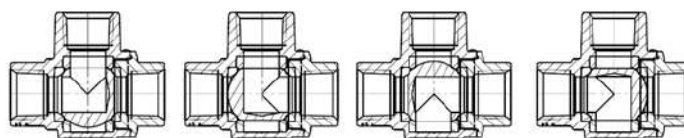

### OPTIONS

- Rack and pinion pneumatic actuator (spring return or double acting)
- S.7241 without handle, actuator ready
- Various actuator linkage kit



## s.7241L NPT XCES7241L - 5941

Each user should perform his own tests to find out the suitability for his particular application. BONOMI INDUSTRIES makes no warranty, express or implied, as to the shape, fit or function of a product for any application. Contact us or consult with your supplier for additional information on the suitability of the BONOMI INDUSTRIES products with your specific field of use.



INDUSTRY

Part description	Q.ty	Material
1 Sand blasted unplated body	1	CW617N
2 Seat	2	PTFE
3 Seat	2	PTFE
4 Chrome plated ball	1	CW617N
5 Sand blasted unplated end-cap	1	CW617N
6 Washer	1	PTFE carbon filled 25%
7 Nickel plated stem O-ring design	1	CW617N
8 O-Ring	2	FPM
9 Screw handle stop	1	CW617N
10 Black dipped coating	1	1.4310 / AISI302
11 Stainless steel screw	1	CW617N
12 Unplated stop	1	1.4301 / AISI304
13 Zinc plated steel nut	1	DD11 (EN10111)
14 Stainless steel Exagonal screw	1	PVC

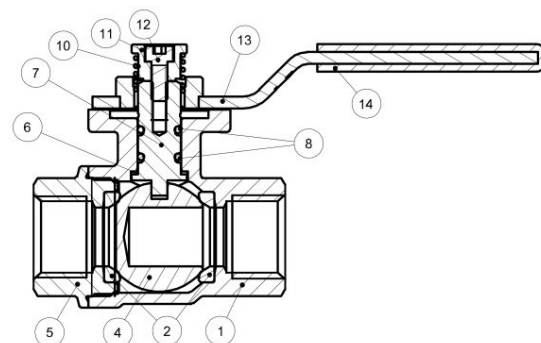

Code	S72D41L	S72E41L	S72F41L
Size (inch)	1/2"	3/4"	1"
DN (inch)	0.591	0.787	0.984
I (inch)	0.610	0.709	0.827
L (inch)	2.559	3.110	3.642
G (inch)	1.280	1.555	1.831
H (inch)	1.280	1.555	1.673
N (inch)	1.358	1.654	1.949
ØA (inch)	1.417	1.417	1.417
ØC (inch)	Ø 0.205 (M6)	Ø 0.205 (M6)	Ø 0.205 (M6)
p (inch)	4.055	4.055	4.055
H1 (inch)	2.185	2.461	2.579
S (inch)	0.087	0.087	0.087
T (inch)	0.394	0.394	0.394
F (inch)	0.287	0.327	0.327
CH (inch)	1.063	1.260	1.614
Flange connection DIN ISO 522 DIN 3337	F03	F03	F03

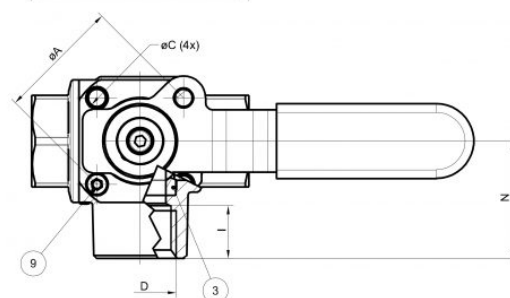
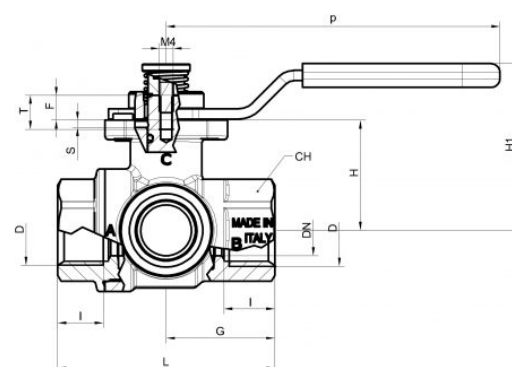

### TORQUE FOR ACTUATOR SIZING IN-LB

Delta P --> Valve size	0÷230 PSI	
	to open	to close
1/2"	93	93
3/4"	115	115
1"	195	195

### TORQUE CORRECTION FACTORS

Valve torque can vary according to operating frequency, temperature and friction characteristics of the media.

If media has more or less friction than water, multiply torque by the following factors:

Lubricating oils or liquids	0.8
Dry gases, natural gas	1.5
Slurries or liquids bearing abrasive particles	1.5÷2.5



# s.7300L

## 3-way, lever, 4 seats, T-port

**Female/Female/Female**  
**1/4" - 2"**  
**EN 10226-1**

The s.7300L series has a ball seal at every port, and offers a wide variety of possible flow configurations. Positive shut-off can be achieved at any of the exiting ports. By specifying the appropriate ball port configuration, the T-port design allows flow direction to be adjusted for virtually any situation and is ideal for mixing applications. Our s.73 multi-port valves can reduce the number of valves required in piping systems and can significantly lower overall costs by replacing two or three conventional 2-way valves, eliminating excess fittings, saving space and simplifying automation.



### QUALITY

- Electronic 100% seal test guaranteed
- No metal-to-metal moving parts
- No maintenance ever required
- Silicone-free lubricant on all seals
- Chrome plated brass ball for longer life
- Each valve is seal tested for maximum safety
- Performs well in any orientation
- Strong configuration

### BODY

- Hot forged sand blasted, external nickel plated brass body and cap sealed with Loctite® or equivalent thread sealant
- Integrated ISO 5211 /DIN 3337 mounting flange for universal connection to actuator
- Finest brass according to EN 12165 and EN 12164 specifications
- 3-way T-port design for flow mixing

### STEM

- Blowout-proof nickel plated brass stem
- Maintenance-free, double FPM O-rings at the stem for maximum safety

### SEALING

- Pure PTFE self-lubricating seats with flexible-lip design
- Four seats design for mixing of various fluids in the system

### THREADS

- EN 10226-1, ISO 228 parallel female threads

### FLOW

- 100% full port for maximum flow

### HANDLE

- Geomet® carbon steel handle with thick PVC dip coating. Handle coating offers both thermal and electrical protection
- Handle removable with valve in service
- **WARNING:** do not exceed reasonable temperature and/or electrical load

### WORKING PRESSURE & TEMPERATURE

- 20 bar (300 PSI) non-shock cold working pressure
- -20°C to +150°C (-4°F to +302°F)
- **WARNING:** freezing of the fluid in the installation may severely damage the valve

### UPON REQUEST

- Custom design
- Stainless steel stem
- Configurations with 4 seats & L-port (s.7200L) or 2 seats & L-port (s.7600L)

### PED DIRECTIVE

- The product meets the requirements of PED Directive 2014/68/UE and according to art.4 par.3, it does not require CE marking

### APPROVED BY OR IN COMPLIANCE WITH

- RoHS Compliant (EU)
- EAC – Declaration of conformity (Russia, Kazakhstan, Belarus)

**NOTE:** approvals apply to specific configurations/sizes only.

S.73 3-WAY "T" PORT OPERATING POSITIONS

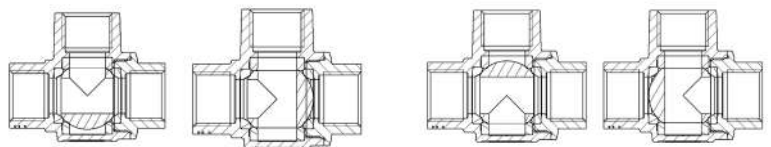

### OPTIONS

- Rack and pinion pneumatic actuator (spring return or double acting)
- S.7300 without handle actuator ready
- Various actuator linkage kit





Part description		Q.ty	Material
1	Nickel plated body (external nickel plated, unplated inside)	1	CW617N
2	Seat	2	PTFE
3	Seat	2	PTFE
4	Chrome plated ball	1	CW617N
5	Nickel plated end cap (external nickel plated, unplated inside)	1	CW617N
6	Washer	1	PTFE carbon filled 25%
7	Nickel plated stem O-ring design	1	CW617N
8	O-Ring	2	FPM
9	Screw handle stop	1	CW617N
10	Spring	1	1.4310 / AISI 302
11	Unplated spring bushing	1	CW617N
12	Stainless steel screw	1	1.4301 / AISI 304
13	Geomet® plated steel handle	1	DD11 (EN10111)
14	Black dipped coating	1	PVC
15	Unplated cap	1	CW614N
16	Stainless steel Hexagonal screw	1	1.4301 / AISI304
17	Square adapter 11-14 (only for 1 1/4" size)	1	Steel
18	Washer	1	PTFE
19	Unplated reduction (only 1/4" and 3/8" sizes)	3	CW617N

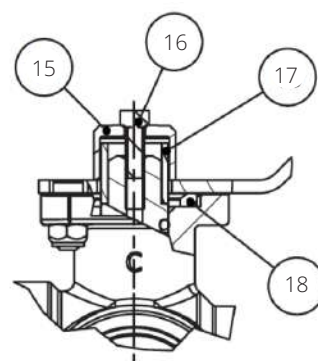
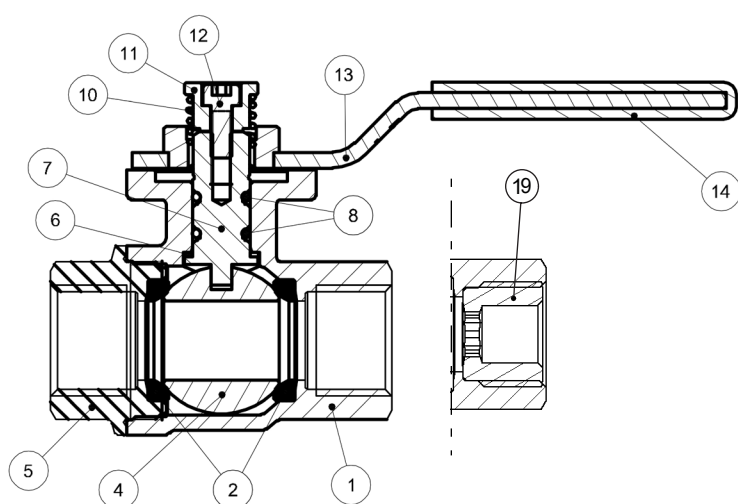



Code	S73B00L	S73C00L	S73D00L	S73E00L	S73F00L	S73G00L	S73H00L	S73I00L
Size (inch)	1/4"	3/8"	1/2"	3/4"	1"	1 1/4"	1 1/2"	2"
DN (mm)	8	10	15	20	25	30.4	38	48
I (mm)	12	12	16.5	19	22.5	25	26	29
L (mm)	65	65	65	79	92.5	109.5	126	150
G (mm)	32.5	32.5	32.5	39.5	46.5	55	63	75
H (mm)	32.5	32.5	32.5	39.5	42.5	56	62.5	72
N (mm)	34.5	34.5	34.5	42	49.5	60	69	82
ØA (mm)	36	36	36	36	36	50	50	50
ØC (mm)	Ø5.6	Ø5.6	Ø5.6	Ø5.6	Ø5.6	Ø6.6	Ø6.6	Ø6.6
p (mm)	103	103	103	103	103	145	145	145
H1 (mm)	55.5	55.5	55.5	62.5	65.5	79.3	85.5	93.4
S (mm)	2.2	2.2	2.2	2.2	2.2	3.2	3.2	3.2
T (mm)	10	10	10	10	10	14	14	14
F (mm)	7.3	7.3	7.3	8.3	8.3	14.5	14.5	14.5
CH (mm)	27	27	27	32	41	50	55	70
Flange connection DIN ISO 522 DIN 3337	F03	F03	F03	F03	F03	F05	F05	F05
Kv (m³/h) straight pattern	TBD	TBD	9.7	28.2	43.3	57.0	94.5	161.0
Kv (m³/h) 90° pattern	TBD	TBD	5.3	11.6	16.8	26.7	43.3	69.2

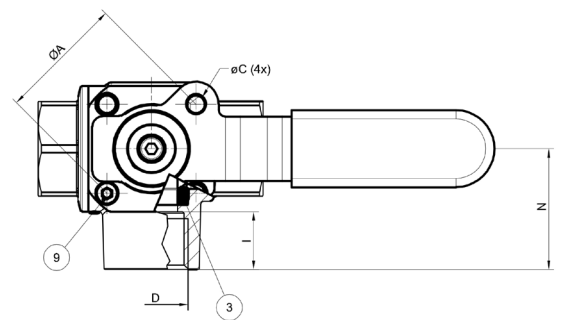
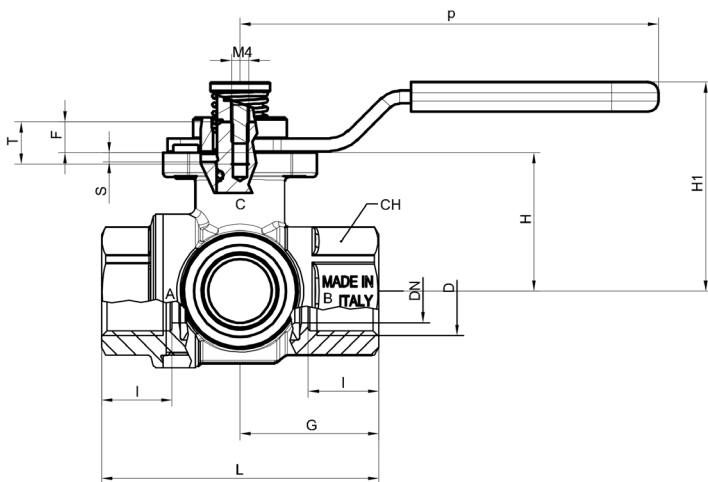

### TORQUE FOR ACTUATOR SIZING N.M

Delta P -->	0÷16 bar	
Valve size	to open	to close
1/4" - 3/8" - 1/2"	10,5	10,5
3/4"	13	13
1"	29,5	29,5
1 1/4"	14	14
1 1/2"	23	23
2"	38	38

### TORQUE CORRECTION FACTORS

Valve torque can vary according to operating frequency, temperature and friction characteristics of the media. If media has more or less friction than water, multiply torque by the following factors:

Lubricating oils or liquids	0.8
Dry gases, natural gas	1.5
Slurries or liquids bearing abrasive particles	1.5÷2.5

With the configuration of T-port a stop pin can be fixed in any position of the 4 provided in the flange (1, 2, 3 or 4) and the lever can be rotated freely through 90°, the flow assumes the directions indicated in the diagram; in case of need the lever can be pulled upwards and you can reach any of the four possible positions.

An alternative is to mount 2 pins in 2 near holes (e.g. 1 and 2). In this case, the valve does not assume a predetermined position but can be actuated just by pulling the lever towards the top.

The valve allows also to block the lever thanks to the addition of a lock on the lever's protrusion (in the drawing you can see position 2). The mixing configuration is achieved by placing the pin in position 2. The flows to be mixed enter through A and C and exit through A+C.

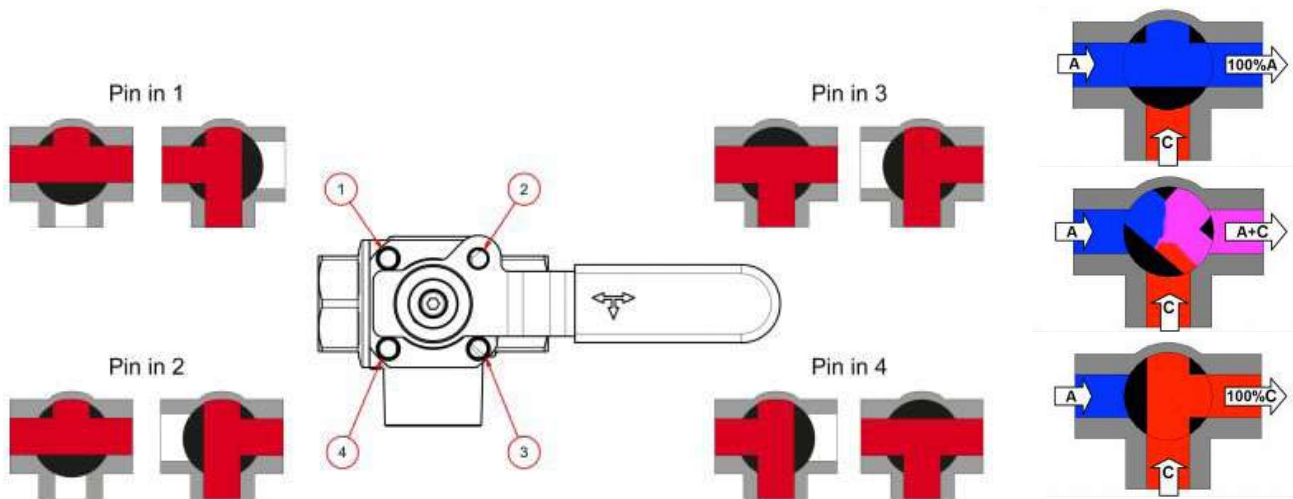

### PRESSURE DROP CHART (STRAIGHT FLOW PATTERN)

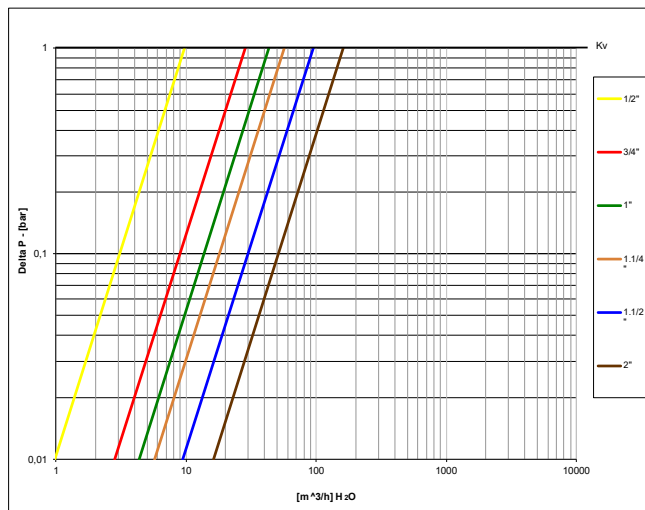

### PRESSURE DROP CHART (90° FLOW PATTERN)

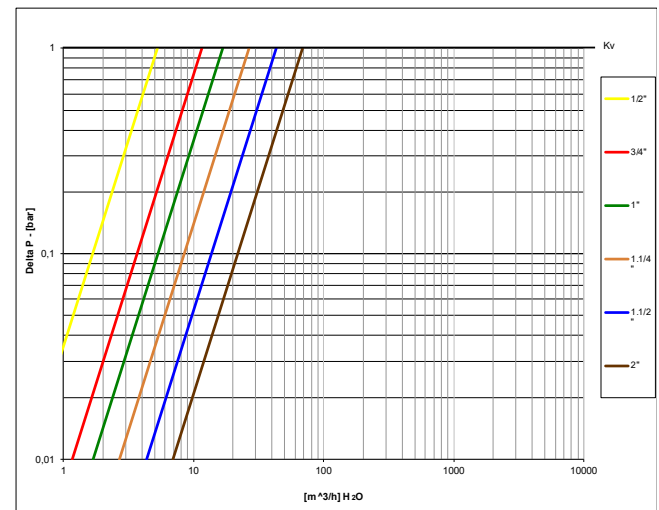



# s.7341L

## 3-way, lever, 4 seats, T-port

**Female/Female/Female**  
**1/2" - 2"**  
**ISO 5211**

The s.7341L series has a ball seal at every port, and offers a wide variety of possible flow configurations. Positive shut-off can be achieved at any of the exiting ports. By specifying the appropriate ball port configuration, the T-port design allows flow direction to be adjusted for virtually any situation and is ideal for mixing applications. Our s.73 multi-port valves can reduce the number of valves required in piping systems and can significantly lower overall costs by replacing two or three conventional 2-way valves, eliminating excess fittings, saving space and simplifying automation.



### QUALITY

- Electronic 100% seal test guaranteed
- No metal-to-metal moving parts
- No maintenance ever required
- Silicone-free lubricant on all seals
- Chrome plated brass ball for longer life
- Each valve is seal tested for maximum safety
- Performs well in any orientation
- Strong configuration

### BODY

- Hot forged sand blasted, external nickel plated brass body and cap sealed with Loctite® or equivalent thread sealant
- Integrated ISO 5211 /DIN 3337 mounting flange for universal connection to actuator
- Finest brass according to EN 12165 and EN 12164 specifications
- 3-way T-port design for flow mixing

### STEM

- Blowout-proof nickel plated brass stem
- Maintenance-free, double FPM O-rings at the stem for maximum safety

### SEALING

- Pure PTFE self-lubricating seats with flexible-lip design
- Four seats design for mixing of various fluids in the system

### THREADS

- NPT taper ANSI B.1.20.1 female threads

### FLOW

- 100% full port for maximum flow

### HANDLE

- Geomet® carbon steel handle with thick PVC dip coating. Handle coating offers both thermal and electrical protection
- Handle removable with valve in service
- **WARNING:** do not exceed reasonable temperature and/or electrical load

### WORKING PRESSURE & TEMPERATURE

- 300 PSI (20 bar) non-shock cold working pressure
- -4°F to +302°F (-20°C to +150°C)
- **WARNING:** freezing of the fluid in the installation may severely damage the valve

### UPON REQUEST

- Custom design
- Stainless steel stem
- Configurations with 4 seats & L-port (s.7241L) or 2 seats & L-port (s.7641L)

### APPROVED BY OR IN COMPLIANCE WITH

- RoHS Compliant (EU)
- EAC – Declaration of conformity (Russia, Kazakhstan, Belarus)

**NOTE:** approvals apply to specific configurations/sizes only.

S.73 3-WAY "T" PORT OPERATING POSITIONS

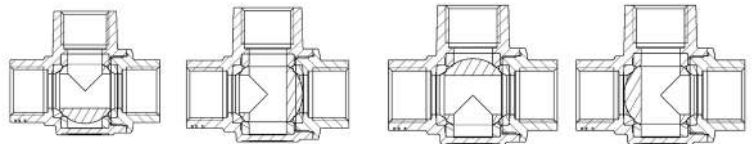

### OPTIONS

- Rack and pinion pneumatic actuator (spring return or double acting)
- S.7341 without handle actuator ready
- Various actuator linkage kit



# s.7341L XCES7341L - 5865

Each user should perform his own tests to find out the suitability for his particular application. BONOMI INDUSTRIES makes no warranty, express or implied, as to the shape, fit or function of a product for any application. Contact us or consult with your supplier for additional information on the suitability of the BONOMI INDUSTRIES products with your specific field of use.



	Part description	Q.ty	Material
1	Sand blasted unplated body	1	CW617N
2	Seat	2	PTFE
3	Seat	2	PTFE
4	Chrome plated ball	1	CW617N
5	Sand blasted unplated end-cap	1	CW617N
6	Washer	1	PTFE carbon filled 25%
7	Nickel plated stem O-ring design	1	CW617N
8	O-Ring	2	FPM
9	Screw handle stop	1	CW617N
10	Spring	1	1.4310 / AISI 302
11	Unplated spring bushing	1	CW617N
12	Stainless steel screw	1	1.4301 / AISI 304
13	Geomet® plated steel handle	1	DD11 (EN10111)
14	Black dipped coating	1	PVC
15	Unplated cap	1	CW614N
16	Stainless steel Hexagonal screw	1	1.4301 / AISI304
17	Square adapter 11-14 (only for 1 1/4" size)	1	Steel
18	Washer	1	PTFE

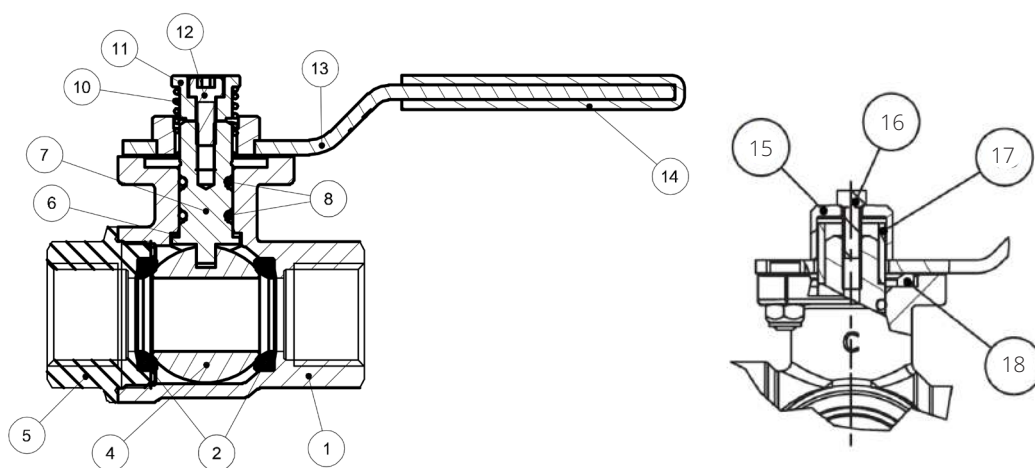



Code	S73D41L	S73E41L	S73F41L	S73G41L	S73H41L	S73I41L
Size (inch)	1/2"	3/4"	1"	1 1/4"	1 1/2"	2"
DN (inch)	0.591	0.787	0.984	1.197	1.496	1.890
I (inch)	0.610	0.709	0.827	0.906	0.965	1.043
L (inch)	2.559	3.110	3.642	4.331	4.961	5.906
G (inch)	1.280	1.555	1.831	2.165	2.480	2.953
H (inch)	1.280	1.555	1.673	2.205	2.460	2.854
N (inch)	1.358	1.654	1.949	2.362	2.717	3.228
ØA (inch)	1.417	1.417	1.417	1.969	1.969	1.969
ØC (inch)	Ø 0.22	Ø 0.22	Ø 0.22	Ø 0.26	Ø 0.26	Ø 0.26
p (inch)	4.055	4.055	4.055	5.709	5.709	5.709
H1 (inch)	2.185	2.461	2.579	3.122	3.366	3.677
S (inch)	0.087	0.087	0.087	0.126	0.126	0.126
T (inch)	0.394	0.394	0.394	0.551	0.551	0.551
F (inch)	0.287	0.327	0.327	0.571	0.571	0.571
CH (inch)	1.063	1.260	1.614	1.969	2.165	2.756
Flange connection DIN ISO 522 DIN 3337	F03	F03	F03	F05	F05	F05
P (ISO 262 Thread)	M4	M4	M4	M5	M5	M5
Cv (GPM) straight pattern	11.2	32.5	50.0	65.8	109.2	186
Cv (GPM) 90° pattern	6.1	13.4	19.5	30.9	50.0	80.0

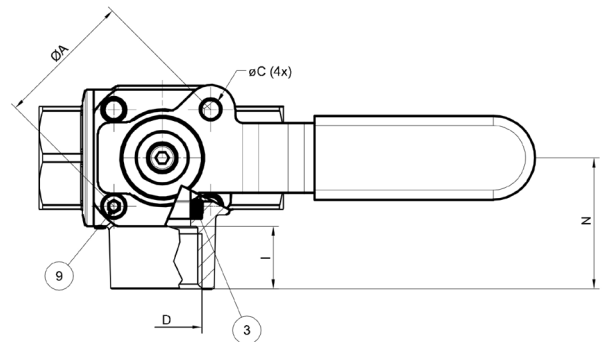
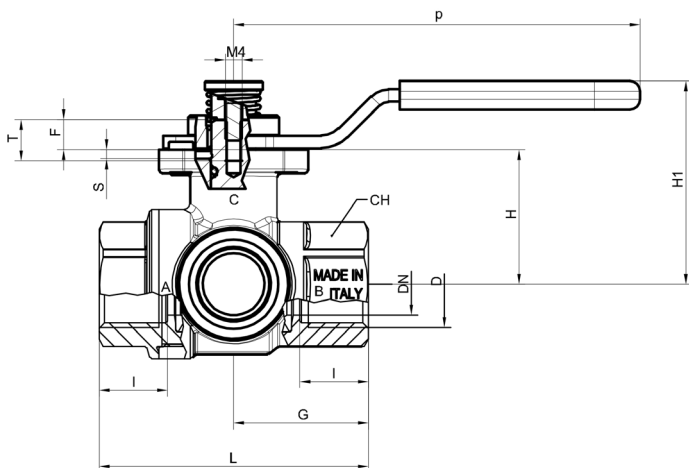

### TORQUE FOR ACTUATOR SIZING N.M

Delta P -->	0÷230 PSI	
	to open	to close
1/2"	93	93
3/4"	115	115
1"	261	261
1 ¼"	124	124
1 ½"	204	204
2"	336	336

### TORQUE CORRECTION FACTORS

Valve torque can vary according to operating frequency, temperature and friction characteristics of the media. If media has more or less friction than water, multiply torque by the following factors:

Lubricating oils or liquids	0.8
Dry gases, natural gas	1.5
Slurries or liquids bearing abrasive particles	1.5÷2.5

With the configuration of T-port a stop pin can be fixed in any position of the 4 provided in the flange (1, 2, 3 or 4) and the lever can be rotated freely through 90°, the flow assumes the directions indicated in the diagram; in case of need the lever can be pulled upwards and you can reach any of the four possible positions.

An alternative is to mount 2 pins in 2 near holes (e.g. 1 and 2). In this case, the valve does not assume a predetermined position but can be actuated just by pulling the lever towards the top.

The valve allows also to block the lever thanks to the addition of a lock on the lever's protrusion (in the drawing you can see position 2). The mixing configuration is achieved by placing the pin in position 2. The flows to be mixed enter through A and C and exit through A+C.

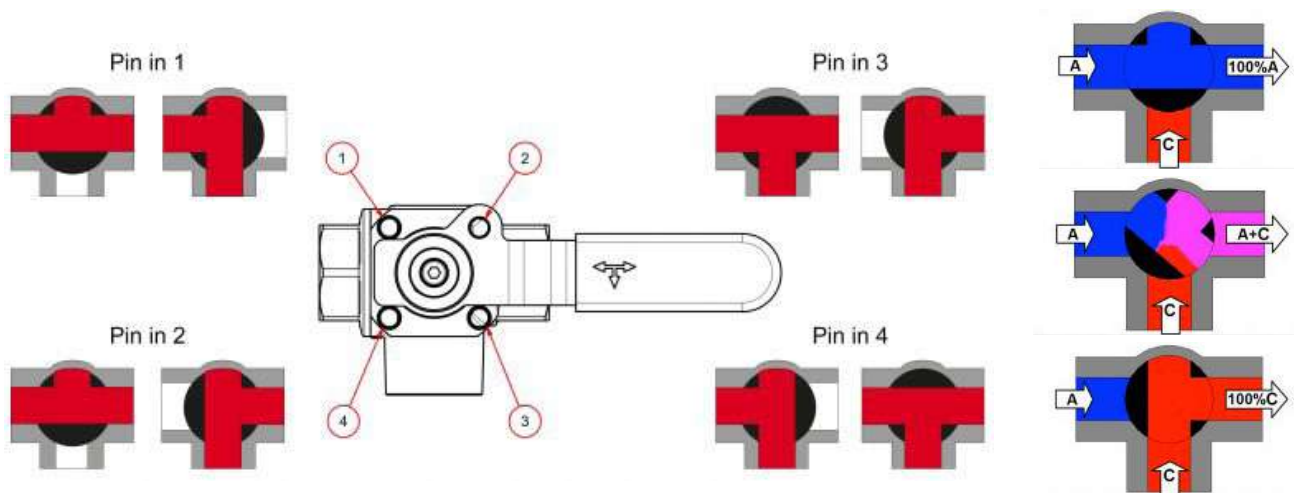

### PRESSURE DROP CHART (STRAIGHT FLOW PATTERN)

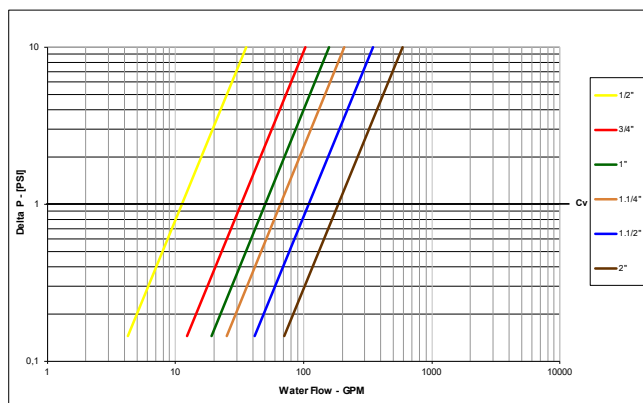

### PRESSURE DROP CHART (90° FLOW PATTERN)

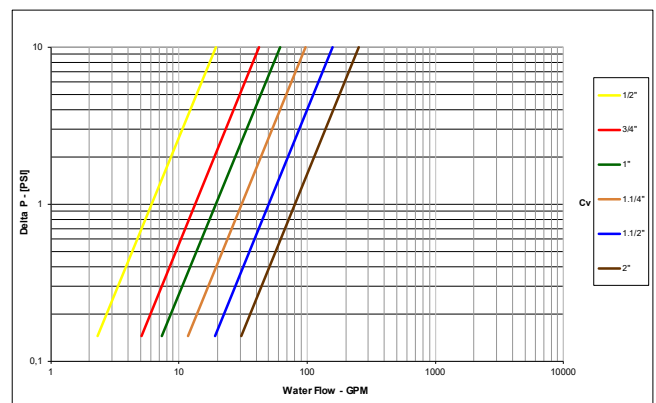



# s.7350L

## 3-way, lever, 4 seats, T-port

**Female/Female/Female**  
**1/2" - 2"**  
**ISO 7/1, BS21**



The s.7350L series has a ball seal at every port, and offers a wide variety of possible flow configurations. Positive shut-off can be achieved at any of the exiting ports. By specifying the appropriate ball port configuration, the T-port design allows flow direction to be adjusted for virtually any situation and is ideal for mixing applications. Our s.73 multi-port valves can reduce the number of valves required in piping systems and can significantly lower overall costs by replacing two or three conventional 2-way valves, eliminating excess fittings, saving space and simplifying automation.

### QUALITY

- Electronic 100% seal test guaranteed
- No metal-to-metal moving parts
- No maintenance ever required
- Silicone-free lubricant on all seals
- Chrome plated brass ball for longer life
- Each valve is seal tested for maximum safety
- Performs well in any orientation
- Strong configuration

### BODY

- Hot forged sand blasted, external nickel plated brass body and cap sealed with Loctite® or equivalent thread sealant
- Integrated ISO 5211 /DIN 3337 mounting flange for universal connection to actuator
- Finest brass according to EN 12165 and EN 12164 specifications
- 3-way T-port design for flow mixing

### STEM

- Blowout-proof nickel plated brass stem
- Maintenance-free, double FPM O-rings at the stem for maximum safety

### SEALING

- Pure PTFE self-lubricating seats with flexible-lip design
- Four seats design for mixing of various fluids in the system

### THREADS

- ISO71, BS21 BSPT taper female threads

### FLOW

- 100% full port for maximum flow

### HANDLE

- Geomet® carbon steel handle with thick PVC dip coating. Handle coating offers both thermal and electrical protection
- Handle removable with valve in service
- **WARNING:** do not exceed reasonable temperature and/or electrical load

### WORKING PRESSURE & TEMPERATURE

- 20 bar (300 PSI) non-shock cold working pressure
- -20°C to +150°C (-4°F to +302°F)
- **WARNING:** freezing of the fluid in the installation may severely damage the valve

### UPON REQUEST

- Custom design
- Stainless steel stem
- Configuration with 2 seats & L-port (s.7650L)

### PED DIRECTIVE

- The product meets the requirements of PED Directive 2014/68/UE and according to art.4 par.3, it does not require CE marking

### APPROVED BY OR IN COMPLIANCE WITH

- RoHS Compliant (EU)
- EAC – Declaration of conformity (Russia, Kazakhstan, Belarus)

**NOTE:** approvals apply to specific configurations/sizes only.

S.73 3-WAY "T" PORT OPERATING POSITIONS

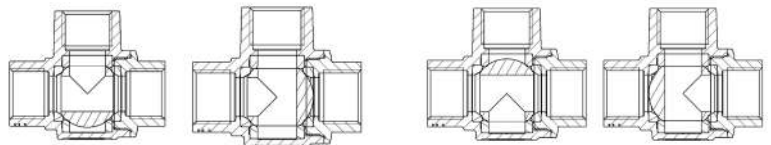

### OPTIONS

- Rack and pinion pneumatic actuator (spring return or double acting)
- S.7350 without handle actuator ready
- Various actuator linkage kit





# s.7350L XCES7350L - 5865

Each user should perform his own tests to find out the suitability for his particular application. BONOMI INDUSTRIES makes no warranty, express or implied, as to the shape, fit or function of a product for any application. Contact us or consult with your supplier for additional information on the suitability of the BONOMI INDUSTRIES products with your specific field of use.



Part description		Q.ty	Material
1	Nickel plated body (external nickel plated, unplated inside)	1	CW617N
2	Seat	2	PTFE
3	Seat	2	PTFE
4	Chrome plated ball	1	CW617N
5	Nickel plated end cap (external nickel plated, unplated inside)	1	CW617N
6	Washer	1	PTFE carbon filled 25%
7	Nickel plated stem O-ring design	1	CW617N
8	O-Ring	2	FPM
9	Screw handle stop	1	CW617N
10	Spring	1	1.4310 / AISI 302
11	Unplated spring bushing	1	CW617N
12	Stainless steel screw	1	1.4301 / AISI 304
13	Geomet® plated steel handle	1	DD11 (EN10111)
14	Black dipped coating	1	PVC
15	Unplated cap	1	CW614N
16	Stainless steel Hexagonal screw	1	1.4301 / AISI304
17	Square adapter 11-14 (only for 1 1/4" size)	1	Steel
18	Washer	1	PTFE

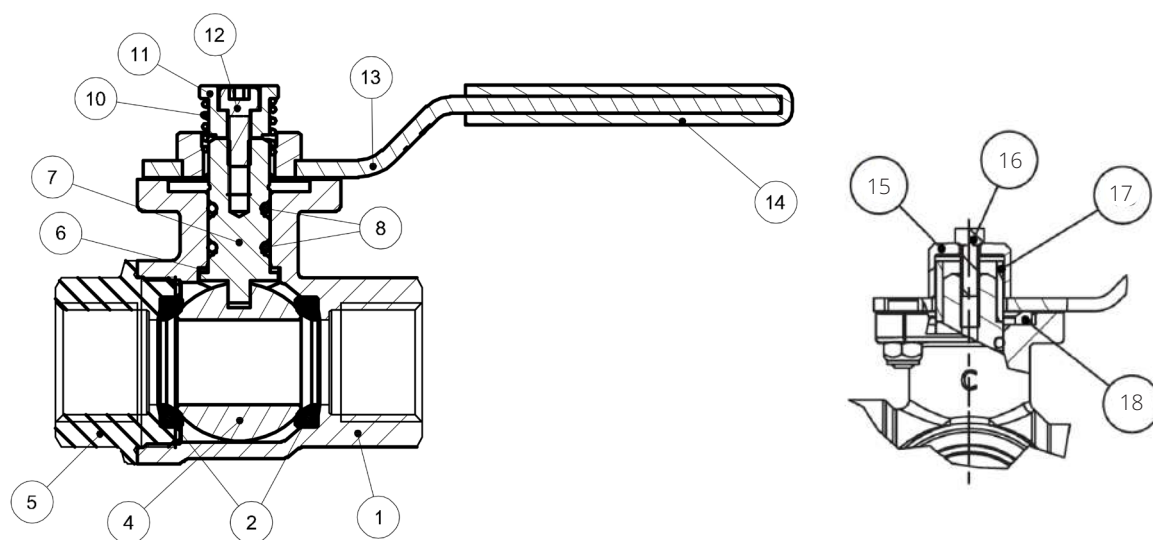



Code	S73D50L	S73E50L	S73F50L	S73G50L	S73H50L	S73I50L
Size (inch)	1/2"	3/4"	1"	1 1/4"	1 1/2"	2"
DN (mm)	15	20	25	30.4	38	48
I (mm)	16.5	19	22.5	25	26	29
L (mm)	65	79	92.5	109.5	126	150
G (mm)	32.5	39.5	46.5	55	63	75
H (mm)	32.5	39.5	42.5	56	62.5	72
N (mm)	34.5	42	49.5	60	69	82
ØA (mm)	36	36	36	50	50	50
ØC (mm)	Ø5.6	Ø5.6	Ø5.6	Ø6.6	Ø6.6	Ø6.6
p (mm)	103	103	103	145	145	145
H1 (mm)	55.5	62.5	65.5	79.3	85.5	93.4
S (mm)	2.2	2.2	2.2	3.2	3.2	3.2
T (mm)	10	10	10	14	14	14
F (mm)	7.3	8.3	8.3	14.5	14.5	14.5
CH (mm)	27	32	41	50	55	70
Flange connection DIN ISO 522 DIN 3337	F03	F03	F03	F05	F05	F05
Kv (m³/h) straight pattern	9.7	28.2	43.3	57.0	94.5	161.0
Kv (m³/h) 90° pattern	5.3	11.6	16.8	26.7	43.3	69.2

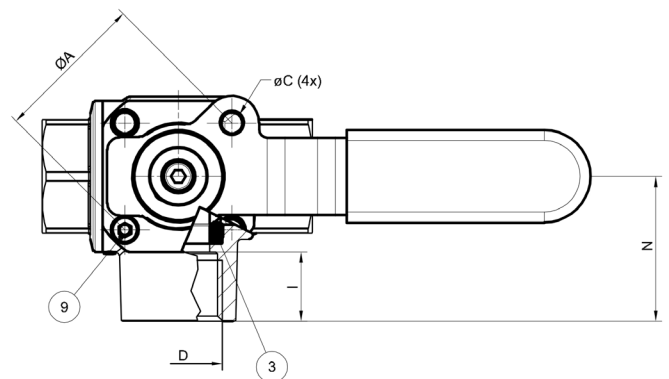
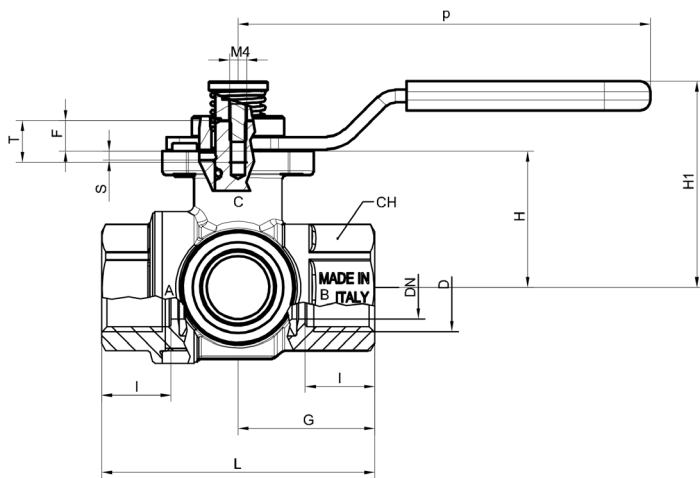

### TORQUE FOR ACTUATOR SIZING N.M

Delta P -->	0÷16 bar	
Valve size	to open	to close
1/2"	10,5	10,5
3/4"	13	13
1"	22	22
1 ¼"	14	14
1 ½"	23	23
2"	38	38

### TORQUE CORRECTION FACTORS

Valve torque can vary according to operating frequency, temperature and friction characteristics of the media. If media has more or less friction than water, multiply torque by the following factors:

Lubricating oils or liquids	0.8
Dry gases, natural gas	1.5
Slurries or liquids bearing abrasive particles	1.5÷2.5

With the configuration of T-port a stop pin can be fixed in any position of the 4 provided in the flange (1, 2, 3 or 4) and the lever can be rotated freely through 90°, the flow assumes the directions indicated in the diagram; in case of need the lever can be pulled upwards and you can reach any of the four possible positions.

An alternative is to mount 2 pins in 2 near holes (e.g. 1 and 2). In this case, the valve does not assume a predetermined position but can be actuated just by pulling the lever towards the top.

The valve allows also to block the lever thanks to the addition of a lock on the lever's protrusion (in the drawing you can see position 2). The mixing configuration is achieved by placing the pin in position 2. The flows to be mixed enter through A and C and exit through A+C.

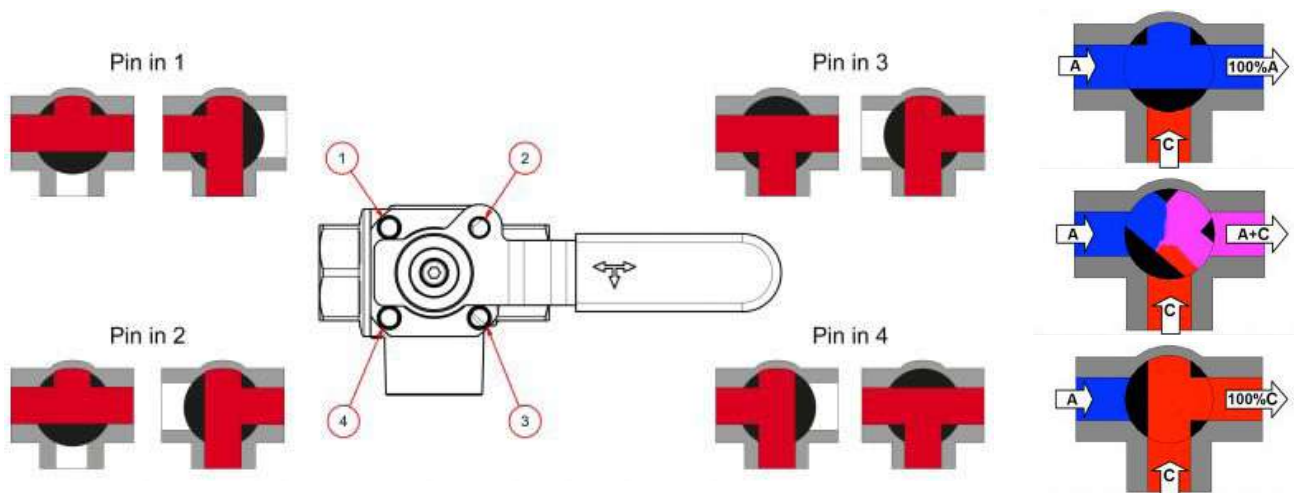

### PRESSURE DROP CHART (STRAIGHT FLOW PATTERN)

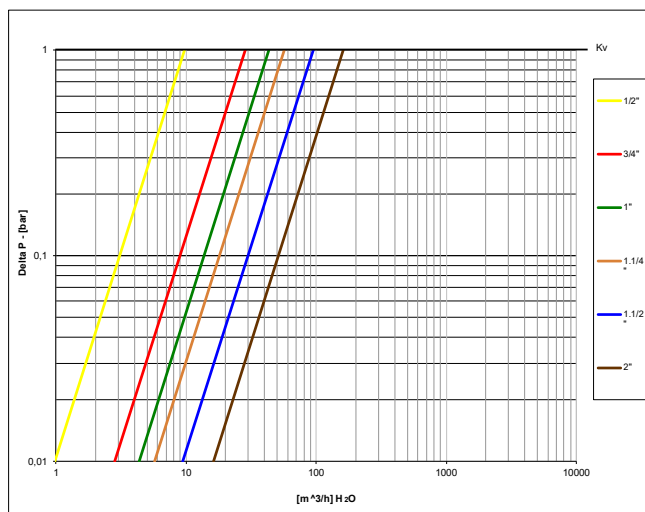

### PRESSURE DROP CHART (90° FLOW PATTERN)

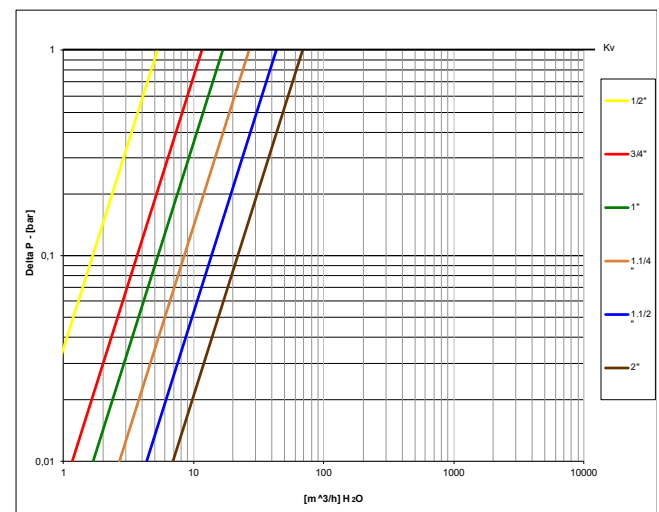



# s.7600L

## 3-way, lever, 2 seats, L-port (diverting)

**Female/Female/Female**  
**1/4" - 2"**  
**EN 10226-1**



The RuB s.7600L is the right choice for fluid diversion and is designed with robust maintenance-free components ensuring ease of operation and safety. With a simple 90° turn, you can divert flow from one downstream outlet to the other. It combines traditional manual operation with modern automation. It is also very easy to convert from its sturdy lever handle to ISO 5211 actuator flange assembly. It features low operating torque and a special wear reducing self-compensating valve seat design that meets our 100,000 cycle life test requirement. The valve can be purchased separately, with handle or with a RuB actuator already mounted.

### QUALITY

- Electronic 100% seal test guaranteed for maximum safety
- No metal-to-metal moving parts
- No maintenance ever required
- Silicone-free lubricant on all seals
- Chrome plated brass ball for longer life
- Each valve is seal tested for maximum safety
- Performs well in any orientation
- Strong configuration

### BODY

- Hot forged sand blasted, external nickel plated brass body and cap sealed with Loctite® or equivalent thread sealant
- Integrated ISO5211 / DIN3337 mounting flange for universal connection to actuator
- Finest brass according to EN 12165 and EN 12164 specifications
- 3-way L-port design for flow diversion

### STEM

- Blowout-proof nickel plated brass stem
- Maintenance-free, double O-rings at the stem for maximum safety

### SEALING

- Reinforced PTFE self-lubricating seats with flexible-lip and wear compensation design

### THREADS

- EN 10226-1, ISO 228 parallel female by female threads

### FLOW

- 100% full port for maximum flow

### HANDLE

- Geomet® carbon steel handle with thick PVC dip coating. Handle coating offers both thermal and electrical protection
- Handle removable with valve in service
- **WARNING:** do not exceed reasonable temperature and/or electrical load

### WORKING PRESSURE & TEMPERATURE

- Shell rating: 30 bar (450 PSI) up to 1", 20 bar (300 PSI) over 1", non-shock cold working pressure
- Seat rating: Delta P max permissible 8 bar (100 PSI)
- -20°C to +150°C (-4°F to +302°F)
- **WARNING:** freezing of the fluid in the installation may severely damage the valve

### UPON REQUEST

- Custom design
- Stainless steel stem (1.4401/ AISI 316)
- Configurations with 4 seats & T-port (s.7300L) or 2 seats & L-port (s.7600L)

### PED DIRECTIVE

- The product meets the requirements of PED Directive 2014/68/UE and according to art.4 par.3, it does not require CE marking.

### APPROVED BY OR IN COMPLIANCE WITH

- RoHS Compliant (EU)
- EAC – Declaration of conformity (Russia – Kazakhstan – Belarus)

**NOTE:** approvals apply to specific configurations/sizes only.

S.76 3-WAY "L" PORT OPERATING POSITIONS

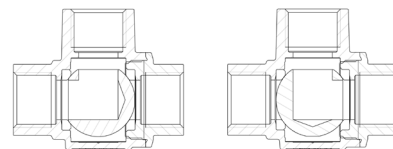

### OPTIONS

- Rack and pinion pneumatic actuator (spring return or double acting)
- Compact Power electric actuator
- ISO 7/1, BS 21 BSPT taper female threads
- S.7600 without handle, actuator ready
- Various actuator linkage kit



# s.7600L XGES7600L - 5942

Each user should perform his own tests to find out the suitability for his particular application. BONOMI INDUSTRIES makes no warranty, express or implied, as to the shape, fit or function of a product for any application. Contact us or consult with your supplier for additional information on the suitability of the BONOMI INDUSTRIES products with your specific field of use.



INDUSTRY

Part description	Q.ty	Material
1 Nickel plated body (External nickel plated, unplated inside)	1	CW617N
2 Seat	2	PTFE graphite filled 15%
3 Chrome plated ball	1	CW617N
4 Sand blasted nickel plated end cap (External nickel plated, unplated inside)	1	CW617N
5 Washer	1	PTFE carbon filled 25%
6 Nickel plated stem O-ring design	1	CW617N
7 O-Ring	2	FPM
8 O-Ring	2	FPM
9 Geomet® plated steel handle	1	DD11 (EN10111)
10 Black dipped coating	1	PVC
11 Stainless steel screw	1	1.4301 / AISI304
12 Unplated stop	1	CW617N
13 Zinc plated steel nut	1	Class 8 (UNI7474)
14 Unplated cap	1	CW614N
15 Stainless steel Exagonal screw	1	1.4301 / AISI304
16 Square adaptor 11-14 (only for 1 1/4 size)	1	Steel
17 Washer	1	PTFE
18 Unplated reduction (only 1/4" and 3/8" sizes)	3	CW617N

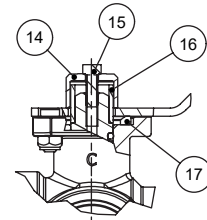
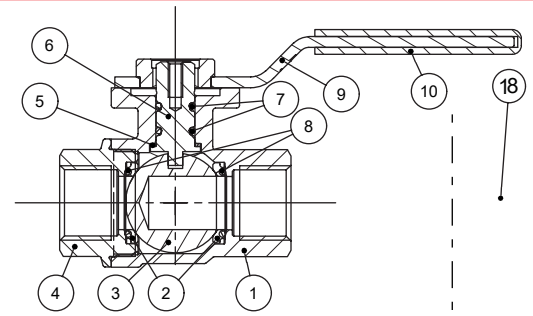

1.1/4"-1.1/2"-2" handle configuration

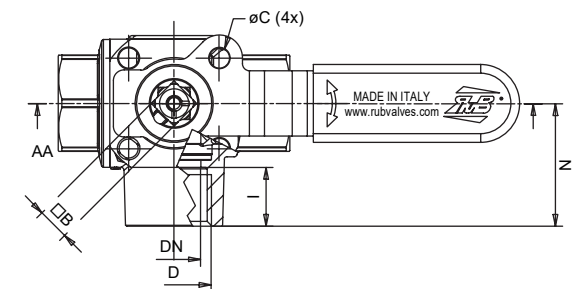
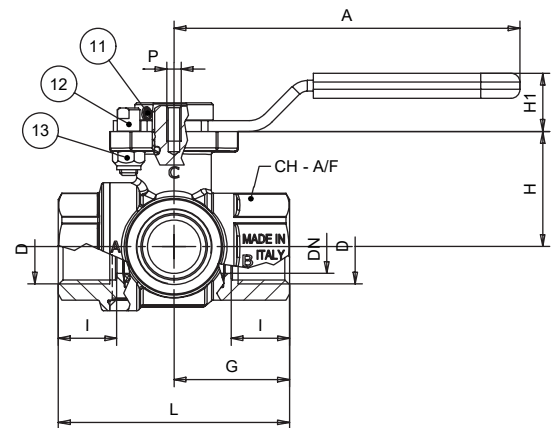

Code	S76B00L	S76C00L	S76D00L	S76E00L	S76F00L	S76G00L	S76H00L	S76I00L
Size (inch)	1/4"	3/8"	1/2"	3/4"	1"	1 1/4"	1 1/2"	2"
DN (mm)	8	10	15	20	25	30.4	38	48
I (mm)	12	12	16.5	19	22.5	25	26	29
L (mm)	65	65	65	79	92.5	109.5	126	150
G (mm)	32.5	32.5	32.5	39.5	46.5	55	63	75
H (mm)	32.5	32.5	32.5	39.5	42.5	56	63.2	72
N (mm)	34.5	34.5	34.5	42	49.5	60	69	82
A (mm)	103	103	103	103	103	145	145	145
øC (mm)	ø5.6	ø5.6	ø5.6	ø5.6	ø5.6	ø6.6	ø6.6	ø6.6
H1 (mm)	23	23	23	23	23	23	23	23
Square B (mm)	9	9	9	9	9	11	11	14
CH A/F (mm)	27	27	27	32	41	50	55	70
Flange connection DIN ISO 522 DIN 3337	F03	F03	F03	F03	F03	F05	F05	F05
P (ISO 262 Thread)	M4	M4	M4	M4	M4	M5	M5	M5
Kv (m³/h)	TBD	TBD	5.7	11.1	16.7	28.1	44.5	71.1

## TORQUE FOR ACTUATOR SIZING N.M

Delta P -->	0±16 bar	
	to open	to close
14" - 3/8" - 1/2"	3,5	3,5
3/4"	4,0	4,0
1"	4,5	4,5
1 1/4"	11,7	11,7
1 1/2"	21,5	21,5
2"	28,0	28,0

## TORQUE CORRECTION FACTORS

Valve torque can vary according to operating frequency, temperature and friction characteristics of the media.

If media has more or less friction than water, multiply torque by the following factors:

Lubricating oils or liquids	0.8
Dry gases, natural gas	1.5
Slurries or liquids bearing abrasive particles	1.5±2.5

## PRESSURE DROP CHART

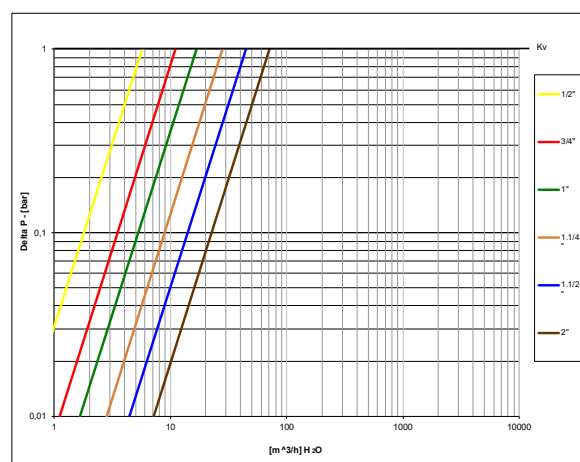



# s.7641L

## 3-way, lever, 2 seats, L-port (diverting)

Female/Female/Female  
1/2" - 2"  
ISO 5211



The **RuB** s.7641L is the right choice for fluid diversion and is designed with robust maintenance-free components ensuring ease of operation and safety. With a simple 90° turn, you can divert flow from one downstream outlet to the other. It combines traditional manual operation with modern automation. It is also very easy to convert from its sturdy lever handle to ISO 5211 actuator flange assembly. It features low operating torque and a special wear reducing self-compensating valve seat design that meets our 100,000 cycle life test requirement. The valve can be purchased separately, with handle or with a **RuB** actuator already mounted.



### QUALITY

- Electronic 100% seal test guaranteed for maximum safety
- No metal-to-metal moving parts
- No maintenance ever required
- Silicone-free lubricant on all seals
- Chrome plated brass ball for longer life
- Each valve is seal tested for maximum safety
- Performs well in any orientation
- Strong configuration

### BODY

- Hot forged sand blasted, external nickel plated brass body and cap sealed with Loctite® or equivalent thread sealant
- Integrated ISO5211 / DIN3337 mounting flange for universal connection to actuator
- Finest brass according to EN 12165 and EN 12164 specifications
- 3-way L-port design for flow diversion

### STEM

- Blowout-proof nickel plated brass stem
- Maintenance-free, double O-rings at the stem for maximum safety

### SEALING

- Reinforced PTFE self-lubricating seats with flexible-lip and wear compensation design

### THREADS

- NPT taper ANSI B.1.20.1 female by female threads

### FLOW

- 100% full port for maximum flow

### HANDLE

- Geomet® carbon steel handle with thick PVC dip coating. Handle coating offers both thermal and electrical protection
- Handle removable with valve in service
- **WARNING:** do not exceed reasonable temperature and/or electrical load

### WORKING PRESSURE & TEMPERATURE

- Shell rating: 450 PSI (30 bar) up to 1", 300 PSI (20 bar) over 1", non-shock cold working pressure
- Seat rating: Delta P max permissible 100 PSI (8 bar)
- -4°F to +350°F (-20°C to +170°C)
- **WARNING:** freezing of the fluid in the installation may severely damage the valve

### UPON REQUEST

- Custom design
- Stainless steel stem (1.4401/ AISI 316)
- Configurations with 4 seats, L-port (s.7241L) or T-port (s.7341L)

### APPROVED BY OR IN COMPLIANCE WITH

- RoHS Compliant (EU)
- EAC – Declaration of conformity (Russia – Kazakhstan – Belarus)

**NOTE:** approvals apply to specific configurations/sizes only.

S.76 3-WAY "L" PORT OPERATING POSITIONS

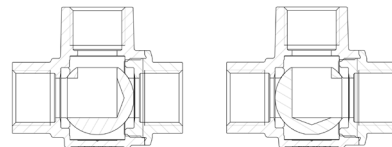

### OPTIONS

- Rack and pinion pneumatic actuator (spring return or double acting)
- Compact Power electric actuator
- S.7641 without handle, actuator ready
- Various actuator linkage kit



# s.7641L XCES7641L - 5942

Each user should perform his own tests to find out the suitability for his particular application. BONOMI INDUSTRIES makes no warranty, express or implied, as to the shape, fit or function of a product for any application. Contact us or consult with your supplier for additional information on the suitability of the BONOMI INDUSTRIES products with your specific field of use.



INDUSTRY

Part description	Q.ty	Material
1 Sand blasted unplated body	1	CW617N
2 Seat	2	PTFE graphite filled 15%
3 Chrome plated ball	1	CW617N
4 Sand blasted unplated end-cap	1	CW617N
5 Washer	1	PTFE carbon filled 25%
6 Nickel plated stem O-ring design	1	CW617N
7 O-Ring	2	FPM
8 O-Ring	2	FPM
9 Geomet® plated steel handle	1	DD11(EN10111)
10 Black dipped coating	1	PVC
11 Stainless steel screw	1	1.4401 / AISI304
12 Unplated stop	1	CW617N
13 Zinc plated steel nut	1	Class 8 (UNI7474)
14 Stainless steel Exagonal screw	1	1.4401 / AISI304
15 Unplated cap	1	CW614N
16 Washer	1	PTFE

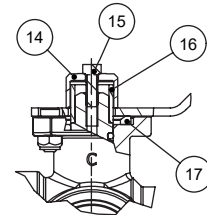
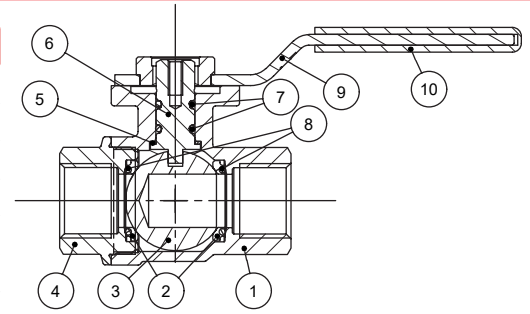

1.1/4"-1.1/2"-2" handle configuration

Code	S76D41L	S76E41L	S76F41L	S76G41L	S76H41L	S76I41L
Size (inch)	1/2"	3/4"	1"	1 1/4"	1 1/2"	2"
DN (inch)	0.591	0.787	0.984	1.197	1.496	1.890
I (inch)	0.610	0.709	0.827	0.906	0.965	1.043
L (inch)	2.559	3.110	3.642	4.311	4.961	5.906
G (inch)	1.280	1.555	1.831	2.165	2.480	2.953
H (inch)	1.280	1.555	1.673	2.205	2.500	2.854
N (inch)	1.358	1.654	1.949	2.362	2.717	3.228
A (inch)	4.055	4.055	4.055	5.709	5.709	5.709
ØC (inch)	Ø 0.22	Ø 0.22	Ø 0.22	Ø 0.26	Ø 0.26	Ø 0.26
H1 (inch)	0.905	0.905	0.905	1.378	1.378	1.378
Square B (inch)	0.354	0.354	0.354	0.551	0.551	0.551
CH A/F (inch)	1.063	1.260	1.614	1.969	2.165	2.756
Flange connection DIN ISO 5211 DIN 3337	F03	F03	F03	F05	F05	F05
P (ISO 262 Thread)	M4	M4	M4	M5	M5	M5
CV (GPM)	6.6	12.9	19.3	32.5	51.4	82.2

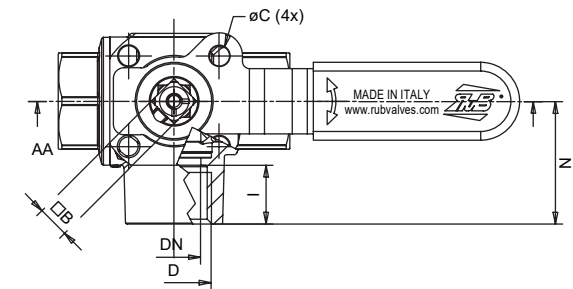
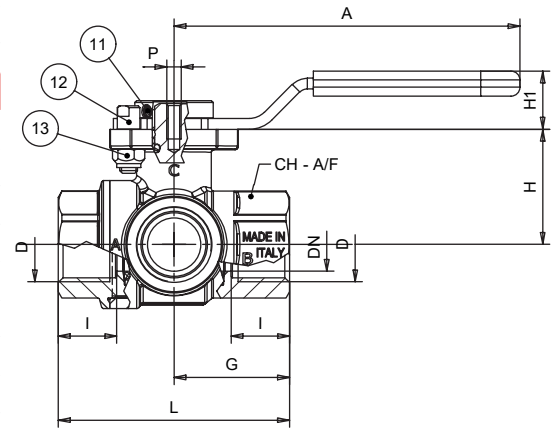

## TORQUE FOR ACTUATOR SIZING IN-LB

Delta P -->	0÷230 PSI	
	to open	to close
Valve size		
1/2"	31	31
3/4"	36	36
1"	40	40
1 1/4"	104	104
1 1/2"	190	190
2"	248	248

## TORQUE CORRECTION FACTORS

Valve torque can vary according to operating frequency, temperature and friction characteristics of the media.

If media has more or less friction than water, multiply torque by the following factors:

Lubricating oils or liquids	0.8
Dry gases, natural gas	1.5
Slurries or liquids bearing abrasive particles	1.5÷2.5

## PRESSURE DROP CHART

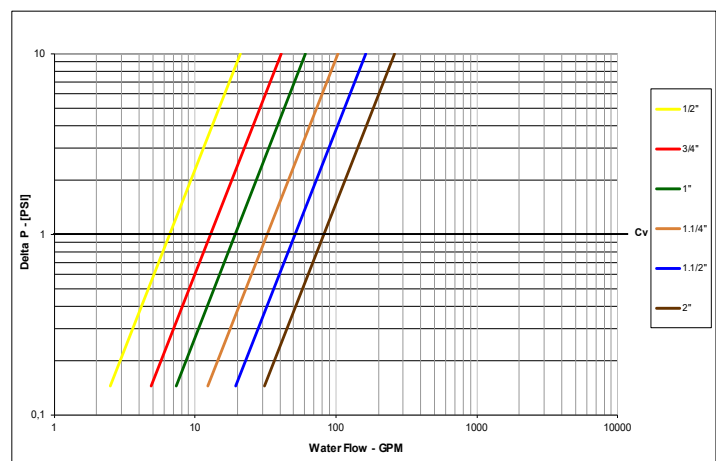



# s.7650L

## 3-way, lever, 2 seats, L-port (diverting)

**Female/Female/Female**  
**1/2" - 2"**  
**ISO 7/1, BS21**

The RuB s.7650L is the right choice for fluid diversion and is designed with robust maintenance-free components ensuring ease of operation and safety. With a simple 90° turn, you can divert flow from one downstream outlet to the other. It combines traditional manual operation with modern automation. It is also very easy to convert from its sturdy lever handle to ISO 5211 actuator flange assembly. It features low operating torque and a special wear reducing self-compensating valve seat design that meets our 100,000 cycle life test requirement. The valve can be purchased separately, with handle or with a RuB actuator already mounted.



### QUALITY

- Electronic 100% seal test guaranteed for maximum safety
- No metal-to-metal moving parts
- No maintenance ever required
- Silicone-free lubricant on all seals
- Chrome plated brass ball for longer life
- Each valve is seal tested for maximum safety
- Performs well in any orientation
- Strong configuration

### BODY

- Hot forged sand blasted, external nickel plated brass body and cap sealed with Loctite® or equivalent thread sealant
- Integrated ISO5211 / DIN3337 mounting flange for universal connection to actuator
- Finest brass according to EN 12165 and EN 12164 specifications
- 3-way L-port design for flow diversion

### STEM

- Blowout-proof nickel plated brass stem
- Maintenance-free, double O-rings at the stem for maximum safety

### SEALING

- Reinforced PTFE self-lubricating seats with flexible-lip and wear compensation design

### THREADS

- ISO 7/1, BS 21 BSPT taper female threads

### FLOW

- 100% full port for maximum flow

### HANDLE

- Geomet® carbon steel handle with thick PVC dip coating. Handle coating offers both thermal and electrical protection
- Handle removable with valve in service
- **WARNING:** do not exceed reasonable temperature and/or electrical load

### WORKING PRESSURE & TEMPERATURE

- Shell rating: 30 bar (450 PSI) up to 1", 20 bar (300 PSI) over 1", non-shock cold working pressure
- Seat rating: Delta P max permissible 8 bar (100 PSI)
- -20°C to +170°C (-4°F to +350°F)
- **WARNING:** freezing of the fluid in the installation may severely damage the valve

### UPON REQUEST

- Custom design
- Stainless steel stem (1.4401/ AISI 316)
- Configurations with 4 seats, L-port (s.7250L) or T-port (s.7350L)

### PED DIRECTIVE

- The product meets the requirements of PED Directive 2014/68/UE and according to art.4 par.3, it does not require CE marking.

### APPROVED BY OR IN COMPLIANCE WITH

- RoHS Compliant (EU)
- EAC – Declaration of conformity (Russia, Kazakhstan, Belarus)

**NOTE:** approvals apply to specific configurations/sizes only.

S.76 3-WAY "L" PORT OPERATING POSITIONS

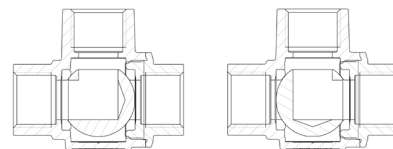

### OPTIONS

- Rack and pinion pneumatic actuator (spring return or double acting)
- Compact Power electric actuator
- S.7650 without handle, actuator ready
- Various actuator linkage kit





# s.7650L XCES7650L - 5942

Each user should perform his own tests to find out the suitability for his particular application. BONOMI INDUSTRIES makes no warranty, express or implied, as to the shape, fit or function of a product for any application. Contact us or consult with your supplier for additional information on the suitability of the BONOMI INDUSTRIES products with your specific field of use.



INDUSTRY

Part description		Q.ty	Material
1	Sand blasted nickel plated body (External nickel plated, unplated inside)	1	CW617N
2	Seat	2	PTFE graphite filled 15%
3	Chrome plated ball	1	CW617N
4	Sand blasted nickel plated end cap (External nickel plated, unplated inside)	1	CW617N
5	Washer	1	PTFE carbon filled 25%
6	Nickel plated stem O-ring design	1	CW617N
7	O-Ring	2	FPM
8	O-Ring	2	FPM
9	Geomet® plated steel handle	1	DD11 (EN10111)
10	Black dipped coating	1	PVC
11	Stainless steel screw	1	1.4301 / AISI304
12	Unplated stop	1	CW617N
13	Zinc plated steel nut	1	Class 8 (UNI7474)
14	Unplated cap	1	CW614N
15	Stainless steel Exagonal screw	1	1.4301 / AISI304
16	Square adaptor 11-14 (only for 1 1/4 size)	1	Steel
17	Washer	1	PTFE

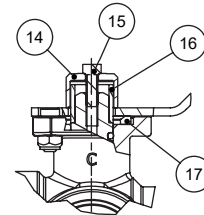
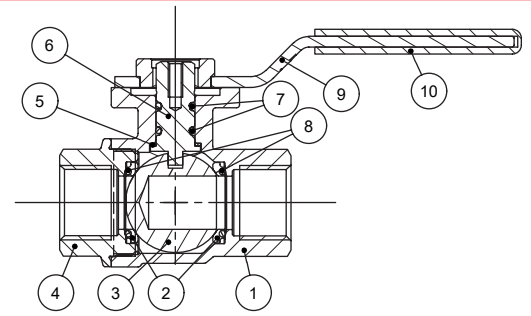

1.1/4"-1.1/2"-2" handle configuration

Code	S76D50L	S76E50L	S76F50L	S76G50L	S76H50L	S76I50L
Size (inch)	1/2"	3/4"	1"	1 1/4"	1 1/2"	2"
DN (mm)	15	20	25	30.4	38	48
I (mm)	16.5	19	22.5	25	26	29
L (mm)	65	79	92.5	109.5	126	150
G (mm)	32.5	39.5	46.5	55	63	75
H (mm)	32.5	39.5	42.5	56	63.2	72
N (mm)	34.5	42	49.5	60	69	82
A (mm)	103	103	103	145	145	145
ØC (mm)	Ø5.6	Ø5.6	Ø5.6	Ø6.6	Ø6.6	Ø6.6
H1 (mm)	23	23	23	23	23	23
Square B (mm)	9	9	9	11	11	14
CH A/F (mm)	27	32	41	50	55	70
Flange connection DIN ISO 522 DIN 3337	F03	F03	F03	F05	F05	F05
P (ISO 262 Thread)	M4	M4	M4	M5	M5	M5
Kv (m³/h)	5.7	11.1	16.7	28.1	44.5	71.1

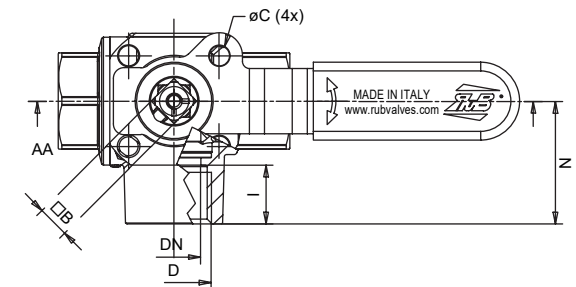
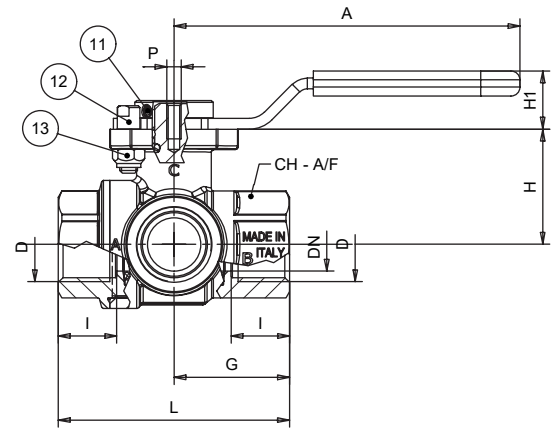

## TORQUE FOR ACTUATOR SIZING N.M

Delta P -->	0÷16 bar	
	to open	to close
Valve size		
1/2"	3,5	3,5
3/4"	4,0	4,0
1"	4,5	4,5
1 1/4"	11,7	11,7
1 1/2"	21,5	21,5
2"	28,0	28,0

## TORQUE CORRECTION FACTORS

Valve torque can vary according to operating frequency, temperature and friction characteristics of the media.

If media has more or less friction than water, multiply torque by the following factors:

Lubricating oils or liquids	0.8
Dry gases, natural gas	1.5
Slurries or liquids bearing abrasive particles	1.5÷2.5

## PRESSURE DROP CHART

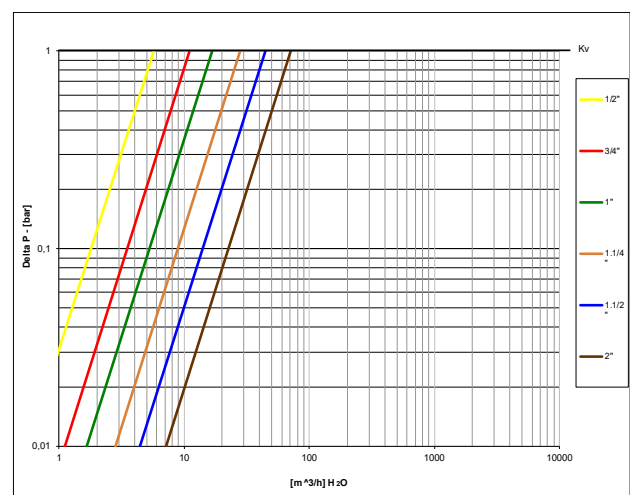



# s.84 EN331 spring return

**Female/Female**  
**1/4" - 2", EN 10226-1**

Access to fluid systems in public places could potentially convert into costs and safety problems. In order to avoid unattended valves being left open with negative economic or environmental consequences, **RuB** developed the automatic self-closing valve.

The valve can be opened normally by rotating the handle 90° and when the user releases the handle, the valve shuts off automatically. Best solution for service stations, trucks, public areas, gardens. The same features are also useful in industrial applications, where a valve must not be left open unattended.



## QUALITY

- 24h 100% seal test guaranteed
- Dual sealing system allows valve to be operated in either direction making installation easier
- No metal-to-metal moving parts
- No maintenance ever required
- Handle clearly shows ball position
- Silicone-free lubricant on all seals
- Travel stops on body to avoid stresses at stem
- Chrome plated brass ball for longer life with rinse hole

## BODY

- Hot forged sand blasted, external nickel plated brass body and cap sealed with Loctite® or equivalent thread sealant
- Finest brass according to EN 12165 and EN 12164 specifications

## STEM

- Blowout-proof nickel plated brass stem
- Maintenance-free, double FPM O-rings at the stem for maximum safety

## SEALING

- Pure PTFE self-lubricating seats with flexible-lip design

## THREADS

- EN 10226-1, ISO 228 parallel female by female threads

## FLOW

- Full port to DIN 3357 for maximum flow

## HANDLE

- Robust spring ensures auto shutt-off with max pressure in valve
- Geomet® carbon steel handle with thick PVC dip coating. Handle coating offers both thermal and electrical protection

## WORKING PRESSURE & TEMPERATURE

- 40 bar (600 PSI) non-shock cold working pressure
- -40°C to +170°C (-40°F to +350°F)
- **WARNING:** freezing of the fluid in the installation may severely damage the valve

## UPON REQUEST

- Stainless steel ball (1.4401 / AISI 316)
- Custom Design

## PED DIRECTIVE

- According to 2014/68/UE module A: it cannot be used with dangerous gases in sizes larger than 25 mm.

## APPROVED BY OR IN COMPLIANCE WITH

- RoHS Compliant (EU)
- EAC – Declaration of conformity (Russia, Kazakhstan, Belarus)

**NOTE:** approvals apply to specific configurations/sizes only.

## OPTIONS

- Stainless steel handle (1.4016 / AISI 430)
- Taper male by parallel female threads

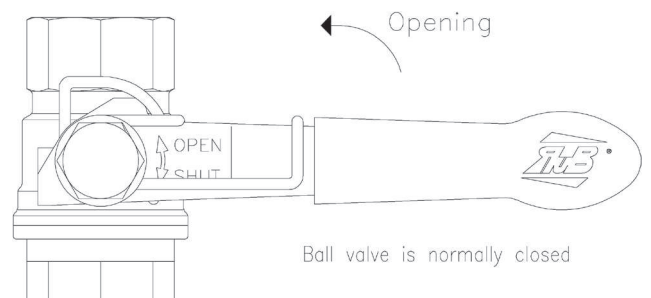

## s.84 EN331 spring return XCES84EMR - 6012

Each user should perform his own tests to find out the suitability for his particular application. BONOMI INDUSTRIES makes no warranty, express or implied, as to the shape, fit or function of a product for any application. Contact us or consult with your supplier for additional information on the suitability of the BONOMI INDUSTRIES products with your specific field of use.



INDUSTRY

Part description		Q.ty	Material
1	Nickel plated body (external treatment)	1	CW617N
2	Seat	2	PTFE
3	Chrome plated ball with rinse hole (read rinse hole on sizes from 3/4" up to 2")	1	CW617N
4	Nickel plated end-cap (external treatment)	1	CW617N
5	Nickel plated stem O-ring design	1	CW617N
6	Unplated spring nut	1	CW617N
7	O-Ring	2	FPM
8	Spring return	1	1.4310 (AISI 302)
9	Yellow PVC coated Geomet® steel handle	1	DD11 (EN10111)

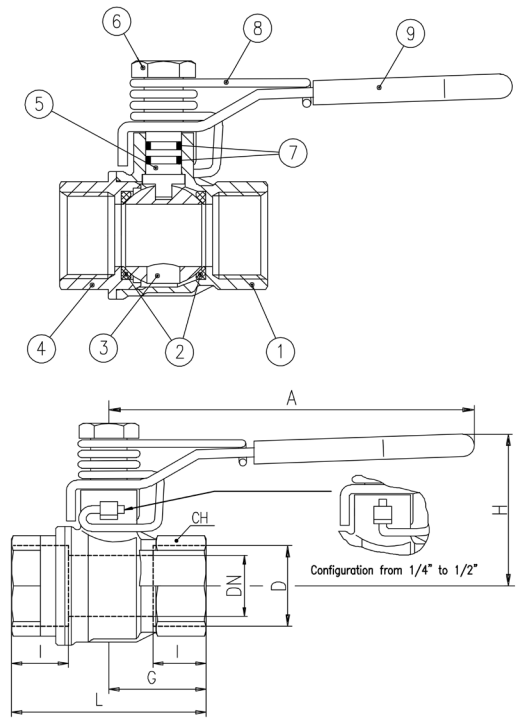

1 1/4" - 2" hollow ball

Compliant to CE 2014/68/UE product  
Equipment category I Module A

Code	S84B00M	S84C00M	S84D00M	S84E00M	S84F00M	S84G00M	S84H00M	S84I00M
D (Inch)	1/4"	3/8"	1/2"	3/4"	1"	1 1/4"	1 1/2"	2"
DN (mm)	8	10	15	20	25	32	40	50
I (mm)	12	12	15,5	17	21	23	23	26,5
L (mm)	45	45	59	64	81	93	102	121
G (mm)	22,5	22,5	29,5	32	40,5	46,5	51	60,5
A (mm)	100	100	100	120	120	158	158	158
H (mm)	38	38	43	50	54	73	79	86
CH (mm)	17	20	25	31	40	49	54	68,5
Kv (m3/h)	3,9	8,2	28	36	62	79	124	178

DN shows the nominal flow diameter. Actual flow diameter complies with full port DIN 3357 part 4.

Ball valves are marked CE on handle from 1 1/4" to 2" as follow: CE XXCODEXX Cat I-A

### PRESSURE-TEMPERATURE CHART

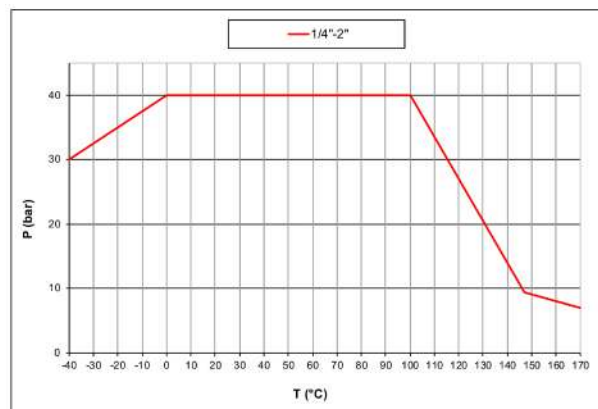

### PRESSURE DROP CHART

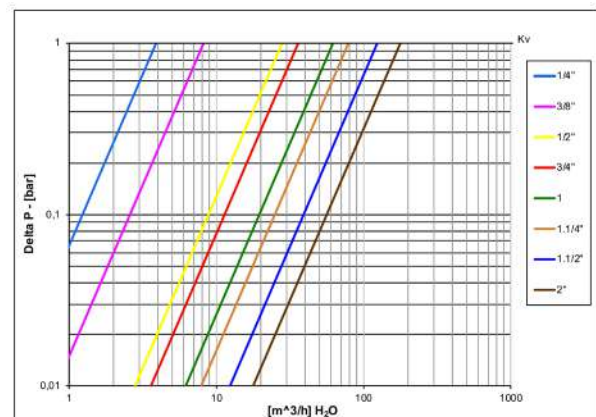



# s.85

**Female/Female**  
**1/4" - 2"**  
**EN 10226-1, packing gland**



## QUALITY

- 24h 100% seal test guaranteed
- Dual sealing system allows valve to be operated in either direction making installation easier
- No metal-to-metal moving parts
- Handle clearly shows ball position
- Silicone-free lubricant on all seals
- Chrome plated brass ball for longer life
- Handle stops on body to avoid stress at stem

## BODY

- Hot forged sand blasted, external nickel plated brass body and cap sealed with Loctite® or equivalent thread sealant
- Finest brass according to EN 12165 and EN 12164 specifications

## STEM

- Blowout-proof nickel plated brass stem
- Pure PTFE adjustable packing gland and reinforced washer for lower torque and easy maintenance

## SEALING

- Pure PTFE self-lubricating seats with flexible-lip design

## THREADS

- EN 10226-1, ISO 228 parallel female by female threads

## FLOW

- Full port to DIN 3357 for maximum flow

## HANDLE

- Geomet® carbon steel handle with thick PVC dip coating. Handle coating offers both thermal and electrical protection
- **WARNING:** do not exceed reasonable temperature and/or electrical load

## WORKING PRESSURE & TEMPERATURE

- 40 bar (600 PSI) non-shock cold working pressure
- -40°C to +170°C (-40°F to +350°F)
- **WARNING:** freezing of the fluid in the installation may severely damage the valve

## UPON REQUEST

- Stainless steel ball and/or stem (1.4401 / AISI 316)
- Glass filled PTFE seals
- Custom design

## PED DIRECTIVE

- According to 2014/68/UE module A: it cannot be used with dangerous gases in sizes larger than 25mm

## APPROVED BY OR IN COMPLIANCE WITH

- RoHS Compliant (EU)
- EAC – Declaration of conformity (Russia, Kazakhstan, Belarus)

**NOTE:** approvals apply to specific configurations/sizes only.

## OPTIONS

- Oval lockable handle **1**
- Patented locking device **2**
- Stainless steel handle (1.4016 / AISI 430) **3**
- T-handle **4**
- Stem extension
- Stubby handle



# s.85 XCES85 - 6012

Each user should perform his own tests to find out the suitability for his particular application. BONOMI INDUSTRIES makes no warranty, express or implied, as to the shape, fit or function of a product for any application. Contact us or consult with your supplier for additional information on the suitability of the BONOMI INDUSTRIES products with your specific field of use.



INDUSTRY

Part description		Q.ty	Material
1	Nickel plated body (external treatment)	1	CW617N
2	Seat	2	PTFE
3	Chrome plated ball	1	CW617N
4	Nickel plated end-cap (external treatment)	1	CW617N
5	Nickel plated stem packing gland design	1	CW617N
6	Nickel plated gland nut	1	CW617N
7	Geomet® nut	1	C4C (EN10263-2)
8	Packing gland seal	1	PTFE
9	Washer	1	PTFE carbon filled 25%
10	Black PVC coated Geomet® steel handle	1	DD11 (EN10111)

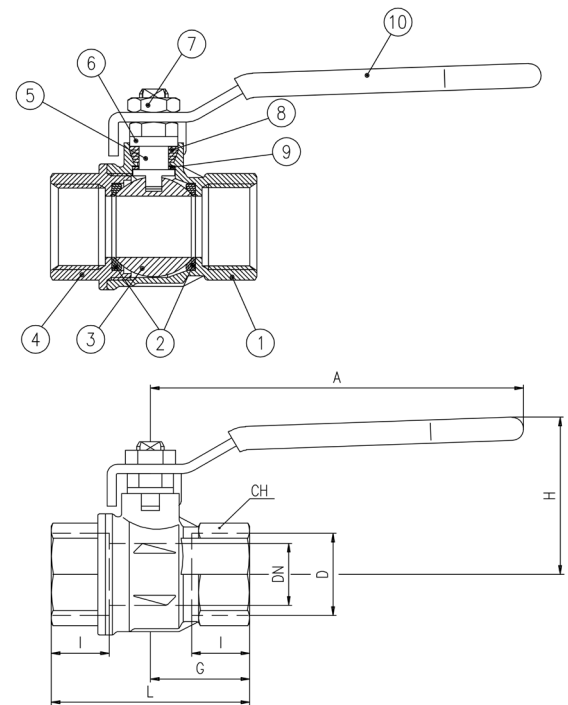

1 1/4"-2" hollow ball

Compliant to CE 2014/68/UE product  
Equipment category I Module A

Code	S85B01	S85C01	S85D01	S85E01	S85F01	S85G01	S85H01	S85I01
D (Inch)	1/4"	3/8"	1/2"	3/4"	1"	1 1/4"	1 1/2"	2"
DN (mm)	8	10	15	20	25	32	40	50
I (mm)	12	12	15,5	17	21	23	23	26,5
L (mm)	45	45	59	64	81	93	102	121
G (mm)	22,5	22,5	29,5	32	40,5	46,5	51	60,5
A (mm)	82	82	100	120	120	158	158	158
H (mm)	39,5	39,5	43	50,5	54,5	76	82	89
CH (mm)	17	20	25	31	40	49	54	68,5
Kv (m3/h)	3,9	8,2	28	42	70	80	125	179

Ball valves are marked CE on handle from 1 1/4" to 2" as follow:  
CE XXCODEXX Cat I-A

## PRESSURE-TEMPERATURE CHART

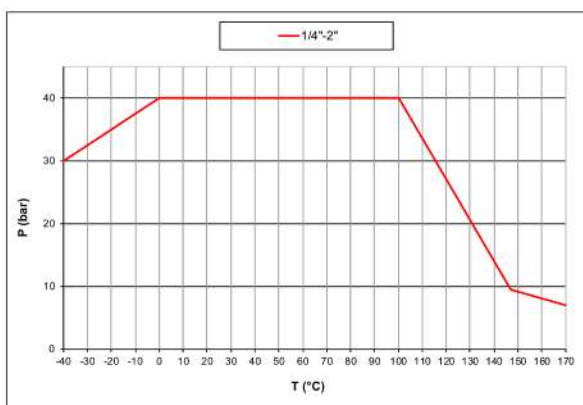

## PRESSURE DROP CHART

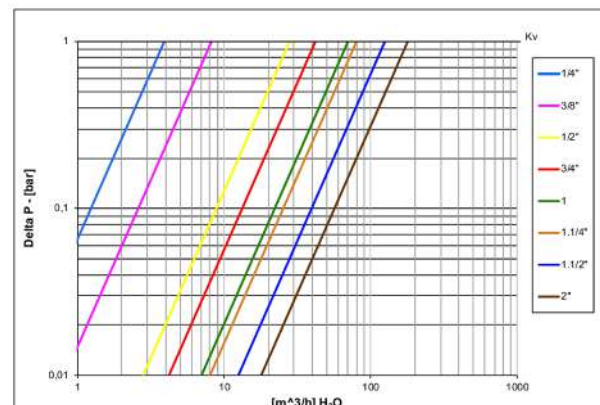



# s.92 barrel drain

**Male/Female  
3/4" - 1"**

The s.92 **RuB** brass ball valve is specifically designed to offer easy and effective drainage of storage tanks and can be installed at the bottom of your barrel or tank and operated with a simple 90° turn to allow full flow accessibility to quickly drain your water, oil, gasoline or other fluids. Its 45° threaded elbow allows for additional pipe connection to conveniently install the drain valve in the best location and in addition the valve features a patented **RuB** tamper-proof locking handle to ensure there is no unauthorized access to the tank. The s.92 can easily be installed on small tanks, utility tanks, overhead farm tanks, and drums as a gravity flow shut-off valve. Another good idea from **RuB!**



## QUALITY

- 24h 100% seal test guaranteed
- Dual sealing system allows valve to be operated in either direction making installation easier
- No metal-to-metal moving parts
- Handle clearly shows ball position
- Silicone-free lubricant on all seals
- Chrome plated brass ball for longer life
- Handle stops on body to avoid stress at stem

## BODY

- Hot forged sand blasted, unplated brass body and cap sealed with Loctite® or equivalent thread sealant
- Finest brass according to EN 12165 and EN 12164 specifications

## STEM

- Blowout-proof nickel plated brass stem
- Pure PTFE adjustable packing gland and reinforced washer for lower torque and easy maintenance

## SEALING

- Glass filled pure PTFE self-lubricating seats with flexible-lip design

## THREADS

- NPT taper ANSI B.1.20.1 male by female threads

## FLOW

- Full port to DIN 3357 for maximum flow

## HANDLE

- Geomet® carbon steel lockable handle patent n. 7074-B/90 with thick PVC dip coating. Handle coating offers both thermal and electrical protection
- Handle removable with valve in service

## WORKING PRESSURE & TEMPERATURE

- 600 PSI (40 bar), (150 WSP / -10 bar all sizes) non-shock cold working pressure
- \*150 psig (10 bar) non-shock steam working pressure. Not suitable for throttling steam
- -40°F to +366°F (-40°C to + 170 °C)
- **WARNING:** freezing of the fluid in the installation may severely damage the valve

## UPON REQUEST

- Stainless steel ball and/or stem (1.4401 / AISI 316)
- Custom design
- Pure PTFE seals
- EN 10226-1, ISO 228 parallel female by female threads
- ISO 7/1, BS 21 BSPT taper female by female threads

## PED DIRECTIVE

- The product meets the requirements of PED Directive 2014/68/UE and according to art.4 par.3, it does not require CE marking

## APPROVED BY OR IN COMPLIANCE WITH

- RoHS Compliant (EU)
- EAC – Declaration of conformity (Russia, Kazakhstan, Belarus)

**NOTE:** approvals apply to specific configurations/sizes only.

## OPTIONS

- Oval lockable handle **1**
- Stainless steel handle (1.4016 / AISI 430) **2**
- Stubby handle **3**
- T-handle **4**
- Non-locking Geomet® carbon steel lever handle



## s.92 barrel drain XGES92S2 - 5813

Each user should perform his own tests to find out the suitability for his particular application. BONOMI INDUSTRIES makes no warranty, express or implied, as to the shape, fit or function of a product for any application. Contact us or consult with your supplier for additional information on the suitability of the BONOMI INDUSTRIES products with your specific field of use.



INDUSTRY

Part description		Q.ty	Material
1	Unplated NPT body	1	CW617N
2	Seat	2	PTFE glass filled 5-15%
3	Chrome plated ball	1	CW617N
4	Unplated NPT end-cap	1	CW617N
5	Nickel plated stem packing gland design	1	CW617N
6	Nickel plated gland nut	1	CW617N
7	Geomet® nut	1	CB4FF (EN10263-2)
8	Packing gland seal	1	PTFE
9	Washer	1	PTFE carbon filled 25%
10	Light blue PVC coated Geomet® steel lockable handle	1	DD11 (EN10111)
11	Elbow	1	CW617N

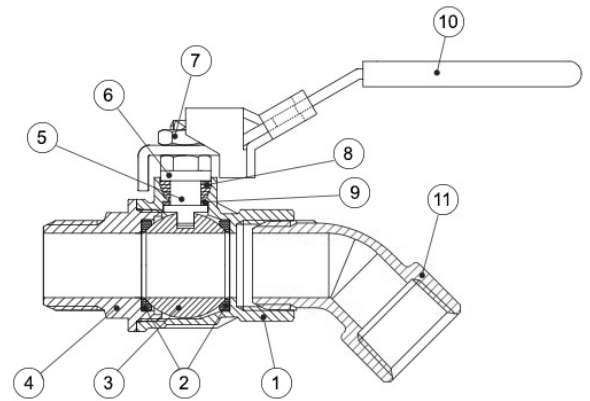

Code	S92ES2MO	S92FS2MO
D (inch)	3/4"	1"
DN (mm)	20	25
I (mm)	17	21
L (mm)	76,5	92,4
G (mm)	32	40,5
A (mm)	117	117
H (mm)	60	64
CH (mm)	31	40
Kv (m3/h)	42	70

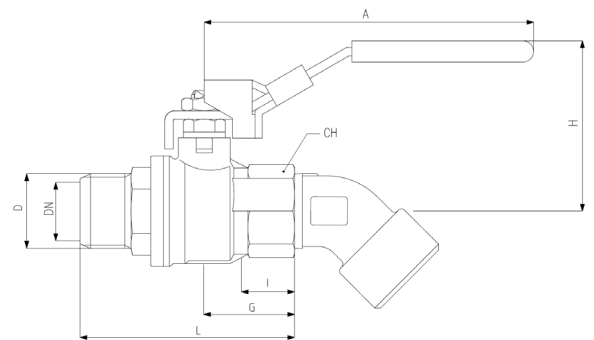

DN shows the nominal flow diameter. Actual flow diameter complies with full port DIN 3357 part 4.

### PRESSURE-TEMPERATURE CHART

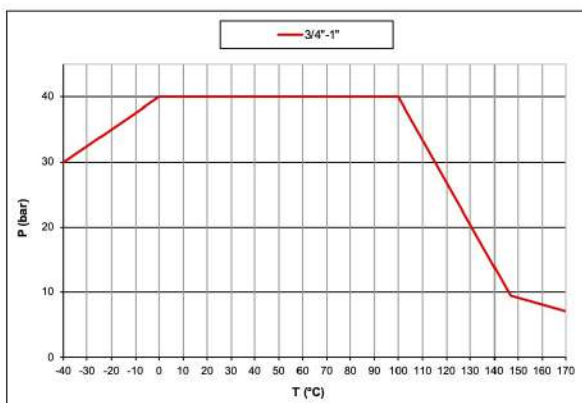

### PRESSURE DROP CHART

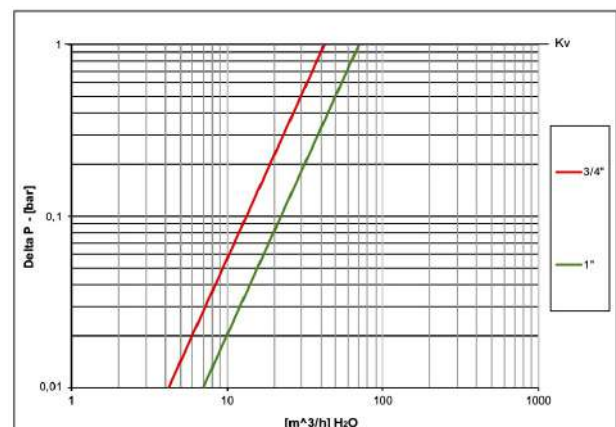



# s.92S NPT solid ball

Female/Female  
1/4" - 4"



## QUALITY

- 24h 100% seal test guaranteed
- Dual sealing system allows valve to be operated in either direction making installation easier
- No metal-to-metal moving parts
- Handle clearly shows ball position
- Silicone-free lubricant on all seals
- Chrome plated brass solid ball for longer life
- Handle stops on body to avoid stress at stem

## BODY

- Hot forged sand blasted, unplated brass body and cap sealed with Loctite® or equivalent thread sealant
- Finest brass according to EN 12165 and EN 12164 specifications

## STEM

- Blowout-proof nickel plated brass stem
- Pure PTFE adjustable packing gland and reinforced washer for lower torque and easy maintenance
- Triple stem seals in sizes over 2"

## SEALING

- Glass filled pure PTFE self-lubricating seats with flexible-lip design

## HANDLE

- Geomet® carbon steel handle with thick PVC dip coating. Handle coating offers both thermal and electrical protection
- **WARNING:** do not exceed reasonable temperature and/or electrical load

## FLOW

- Full port to DIN 3357 for maximum flow
- Solid ball for optimum CV

## OPTIONS UP TO 2" SIZE

- Oval lockable handle up to 2", round over 2" **1**
- Patented locking device for valves up to 4" **2**
- Stainless steel handle (1.4016 / AISI 430) **3**
- Stem extension
- Stubby handle **4**
- T-handle **5**

## THREADS

- NPT taper ANSI B. 1.20.1 female by female threads

## WORKING PRESSURE & TEMPERATURE

- 600 PSI (40 bar) up to 2", 450 PSI (30 bar) over 2", (150 WSP / -10 bar all sizes) non-shock cold working pressure
- 250 PSI (17 bar) non-shock working pressure for LP-Gas
- \*150 psig (10 bar) non-shock steam working pressure. Not suitable for throttling steam
- -40°F to +366°F (-40°C to +185°C)
- **WARNING:** freezing of the fluid in the installation may severely damage the valve

## UPON REQUEST

- Stainless steel ball and/or stem (1.4401 / AISI 316)
- Custom design
- Pure PTFE seals
- \*For sales within EU: CE marking needed, please contact us

## APPROVED BY OR IN COMPLIANCE WITH

- Canadian standards Association (United States, Canada)\*
- Factory Mutual (United States)\*
- RoHS Compliant (EU)
- EAC – Declaration of conformity (Russia, Kazakhstan, Belarus)
- Underwriters Laboratories (United States, Canada)\*:
  - Guide YSDT: LP-Gas shut-off valve
  - Guide YRBX: Flammable liquid shut-off valve
  - Guide YRPV: Gas shut-off valve for use with natural and manufactured gases
  - Guide MHKZ: No. 6 oil at 250°F
- CRN-TSSA acc. to MSS SP110 (Canada)\*
- Kuwait Fire Service Directorate (Kuwait)
- Meeting WW-V-35C Federal U.S. Specification (United States)

**NOTE:** approvals apply to specific configurations/sizes only.

**\*NOTE:** for sizes 1/4" - 1" and 2 1/2"-4"





# x.92S NPT solid ball XCES92S - 6012

Each user should perform his own tests to find out the suitability for his particular application. BONOMI INDUSTRIES makes no warranty, express or implied, as to the shape, fit or function of a product for any application. Contact us or consult with your supplier for additional information on the suitability of the BONOMI INDUSTRIES products with your specific field of use.



INDUSTRY

	Part description	Q.ty	Material
1	Unplated NPT body	1	CW617N
2	Seat	2	PTFE glass filled 5-15%
3	Chrome plated solid ball	1	CW617N
4	Unplated NPT end-cap	1	CW617N
5	Nickel plated stem packing gland design	1	CW617N
6	Nickel plated gland nut	1	CW617N
7	Geomet® nut	1	C4C (EN10263-2)
8	Packing gland seal	1	PTFE
9	Washer	1	PTFE carbon filled 25%
10	Yellow PVC coated Geomet® steel handle	1	DD11 (EN10111)

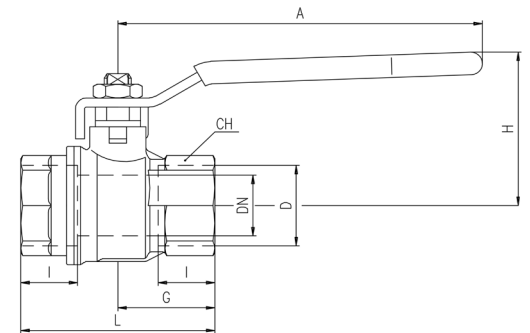
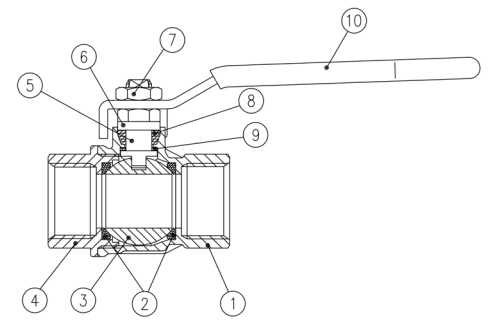

For sales within EU: CE marking needed, please contact us

Code	S92B41	S92C41	S92D41	S92E41	S92F41	S92GP1	S92HP1	S92IP1	S92L41	S92M41	S92N41
D (inch)	1/4"	3/8"	1/2"	3/4"	1"	1 1/4"	1 1/2"	2"	2 1/2"	3"	4"
DN (inch)	0,315	0,374	0,591	0,748	0,945	1,181	1,496	1,890	2,520	2,992	3,937
I (inch)	0,472	0,472	0,61	0,669	0,827	0,906	0,906	1,043	1,26	1,378	1,634
L (inch)	1,772	1,772	2,323	2,520	3,189	3,661	4,016	4,764	6,142	6,969	8,504
G (inch)	0,886	0,886	1,161	1,260	1,594	1,831	2,008	2,382	3,071	3,484	4,252
A (inch)	3,228	3,228	3,937	4,724	4,724	6,22	6,22	6,22	10,039	10,039	10,039
H (inch)	1,563	1,563	1,695	1,988	2,153	2,988	3,236	3,5	5,197	5,512	6,063
CH (inch)	0,669	0,787	0,984	1,22	1,575	1,929	2,126	2,697	3,346	3,898	4,921
Cv (GPM)	4,5	9,5	32,3	48,5	80,9	127,1	214,9	295,8	596,2	896,5	1305,5

DN shows the nominal flow diameter. Actual flow diameter complies with full port DIN 3357 part 4. Stem configuration of valves over 2" is slightly different.

## PRESSURE-TEMPERATURE CHART

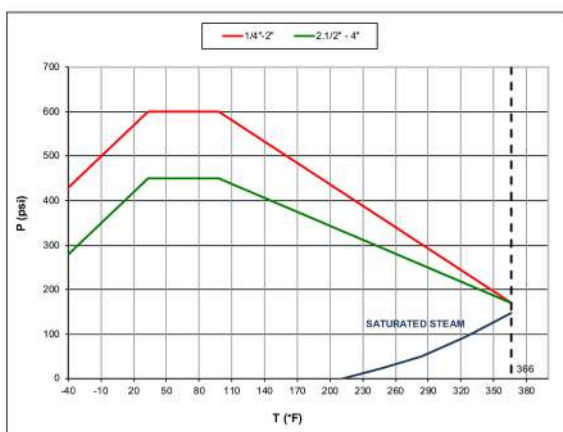

## PRESSURE DROP CHART

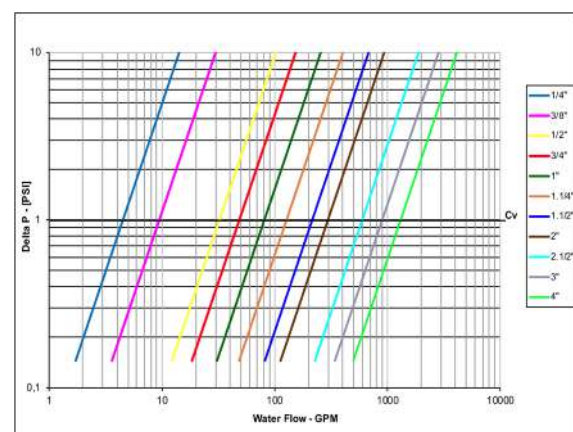



## s.92 NPT SS TRIM XCES9248 - 6012

Each user should perform his own tests to find out the suitability for his particular application. BONOMI INDUSTRIES makes no warranty, express or implied, as to the shape, fit or function of a product for any application. Contact us or consult with your supplier for additional information on the suitability of the BONOMI INDUSTRIES products with your specific field of use.



INDUSTRY

	Part description	Q.ty	Material
1	Unplated NPT body	1	CW617N
2	Seat	2	PTFE glass filled 5-15%
3	Stainless steel ball	1	1.4401 / AISI 316
4	Unplated NPT end-cap	1	CW617N
5	Stainless steel stem packing gland design	1	1.4401 / AISI 316
6	Nickel plated gland nut	1	CW617N
7	Nickel plated handle nut	1	CW617N
8	Packing gland seal	1	PTFE
9	Washer	1	PTFE carbon filled 25%
10	Yellow PVC coated Geomet® steel handle	1	DD11 (EN10111)

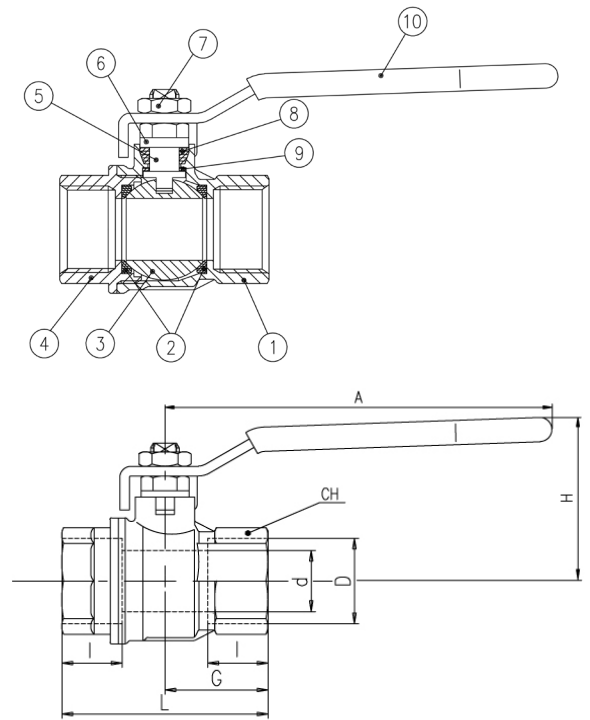

For sales within EU: CE marking needed, please contact us

Code	S92B48	S92C48	S92D48	S92E48	S92F48	S92G48	S92H48	S92I48
D (inch)	1/4"	3/8"	1/2"	3/4"	1"	1 1/4"	1 1/2"	2"
DN (inch)	0,315	0,374	0,591	0,748	0,945	1,181	1,496	1,890
I (inch)	0,472	0,472	0,610	0,669	0,827	0,906	0,906	1,043
L (inch)	1,772	1,772	2,323	2,520	3,189	3,661	4,016	4,764
G (inch)	0,886	0,886	1,161	1,260	1,594	1,831	2,008	2,382
A (inch)	3,228	3,228	3,937	4,724	4,724	6,220	6,220	6,220
H (inch)	1,563	1,563	1,695	1,988	2,153	2,988	3,236	3,500
CH (inch)	0,669	0,787	0,984	1,22	1,575	1,929	2,126	2,697
Cv (GPM)	4,5	9,5	32,3	48,5	80,9	127,10	214,90	295,80

d shows the nominal flow diameter. Actual flow diameter complies with full port DIN 3357 part 4.

### PRESSURE-TEMPERATURE CHART

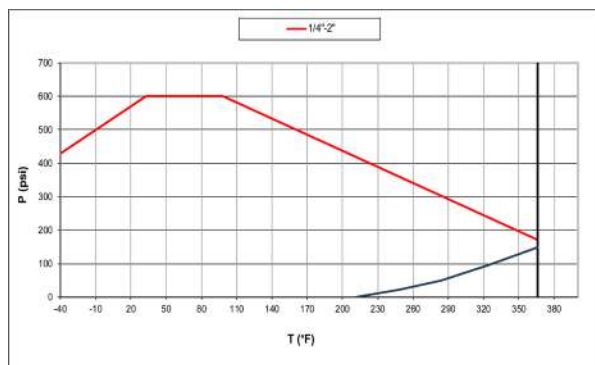

### PRESSURE DROP CHART

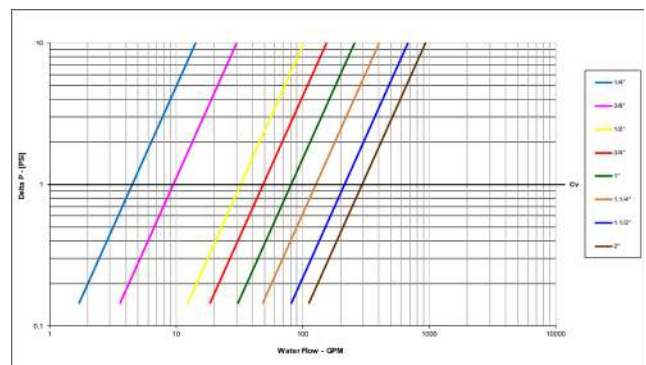



# s.95 NPT spring return

**Female/Female**  
**1/4" - 2"**

Access to fluid systems in public places could potentially convert into costs and safety problems.

In order to avoid unattended valves being left open with negative economic or environmental consequences, **RuB** developed the automatic self-closing valve.

The valve can be opened normally by rotating the handle 90° and when the user releases the handle, the valve shuts off automatically.

Best solution for service stations, trucks, public areas, gardens. The same feature is useful in industrial applications, where a valve must not be left open unattended.



## QUALITY

- 24h 100% seal test guaranteed
- Dual sealing system allows valve to be operated in either direction making installation easier
- No metal-to-metal moving parts
- No maintenance ever required
- Handle clearly shows ball position
- Silicone-free lubricant on all seals
- Handle stops on body to avoid stresses at stem
- Chrome plated brass ball for longer life

## BODY

- Hot forged sand blasted, unplated brass body and cap sealed with Loctite® or equivalent thread sealant
- Finest brass according to EN 12165 and EN 12164 specifications

## STEM

- Blowout-proof nickel plated brass stem
- Maintenance-free, double FPM O-rings at the stem for maximum safety

## SEALING

- Pure PTFE self-lubricating seats with flexible-lip design

## THREADS

- NPT taper ANSI B.1.20.1 female by female threads

## FLOW

- Full port to DIN 3357 for maximum flow

## PED DIRECTIVE

- Assessment according to Pressure Equipment Directive 2014/68/UE module B+D by ICIM (0425)

## OPTIONS

- Stainless steel handle (1.4016 / AISI 430)

## HANDLE

- Robust spring ensures auto shut-off with max pressure in valve
- Geomet® carbon steel handle with thick PVC dip coating. Handle coating offers both thermal and electrical protection
- **WARNING:** do not exceed reasonable temperature and/or electrical load

## WORKING PRESSURE & TEMPERATURE

- 600 PSI (40 bar) non-shock cold working pressure
- 250 PSI (17 bar) non-shock working pressure for LP-Gas
- -40°F / +350°F (-40°C / +170°C)
- **WARNING:** freezing of the fluid in the installation may severely damage the valve

## UPON REQUEST

- Stainless steel ball (1.4401 / AISI 316)
- Custom design

## APPROVED BY OR IN COMPLIANCE WITH

- EAC – Declaration of conformity (Russia, Kazakhstan, Belarus)
- Underwriters Laboratories (United States, Canada):
  - Guide YSDT: LP-Gas shut-off valve
  - Guide YRBX: Flammable liquid shut-off valve
  - Guide YRPV: Gas shut-off valve for use with natural and manufactured gases
  - Guide MHKZ: No. 6 oil at 250°F
- Canadian standards Association (United States, Canada)
- Factory Mutual (United States)
- RoHS Compliant (EU)
- Meeting WW-V-35C Federal U.S. Specification (United States)

**NOTE:** approvals apply to specific configurations/sizes only.

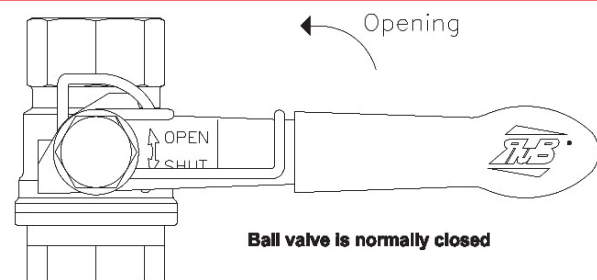

# S.95 NPT SPRING RETURN XGES95MR - 6012

Each user should perform his own tests to find out the suitability for his particular application. BONOMI INDUSTRIES makes no warranty, express or implied, as to the shape, fit or function of a product for any application. Contact us or consult with your supplier for additional information on the suitability of the BONOMI INDUSTRIES products with your specific field of use.



	Part description	Q.ty	Material
1	Unplated NPT body	1	CW617N
2	Seat	2	PTFE
3	Chrome plated ball	1	CW617N
4	Unplated NPT end-cap	1	CW617N
5	Nickel plated stem O-ring design	1	CW617N
6	Unplated spring nut	1	CW617N
7	O-Ring	2	FPM
8	Spring return	1	1.4310 (AISI 302)
9	Yellow PVC coated Geomet® steel handle	1	DD11 (EN10111)

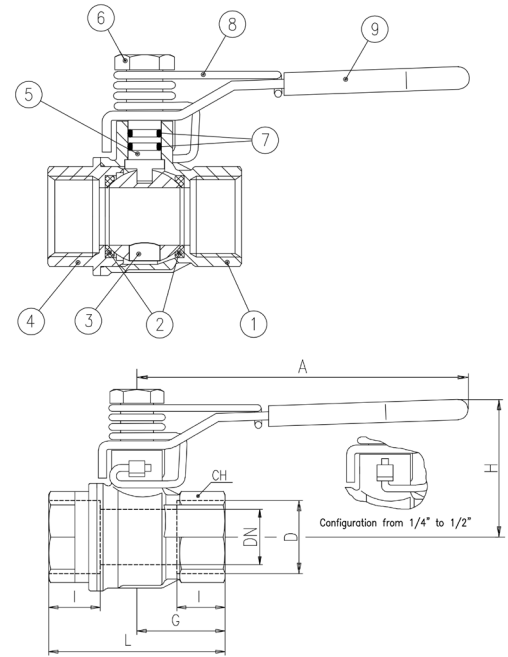

1 1/4"- 2" hollow ball

For sales within EU: CE marking needed, use following codes:  
**S95G41MRCE S95H41MRCE S95I41MRCE**

Code	S95B41MR	S95C41MR	S95D41MR	S95E41MR	S95F41MR	S95G41MR	S95H41MR	S95I41MR
<b>D (inch)</b>	1/4"	3/8"	1/2"	3/4"	1"	1 1/4"	1 1/2"	2"
<b>DN (inch)</b>	0.315	0.375	0.591	0.748	0.945	1.181	1.496	1.890
<b>I (inch)</b>	0.472	0.472	0.610	0.669	0.827	0.906	0.906	1.043
<b>L (inch)</b>	1.772	1.772	2.323	2.520	3.189	3.661	4.016	4.764
<b>G (inch)</b>	0.886	0.886	1.162	1.260	1.594	1.831	2.008	2.382
<b>A (inch)</b>	3.228	3.228	3.937	4.724	4.724	6.220	6.220	6.220
<b>H (inch)</b>	1.480	1.480	1.679	1.956	2.114	2.858	3.094	3.370
<b>CH (inch)</b>	0.669	0.787	0.984	1.220	1.575	1.929	2.126	2.697
<b>Cv (GPM)</b>	4.5	9.5	32.3	48.5	80.9	92.4	144.4	206.8

DN shows the nominal flow diameter. Actual flow diameter complies with full port DIN 3357 part 4. For sales within EU: ball valves are marked CE on handle from 1 1/4" to 2" as follow: CE 0425 cat IIIB+D PS: 5 GAS TS1: -20°C TS2: +60°C

## PRESSURE-TEMPERATURE CHART

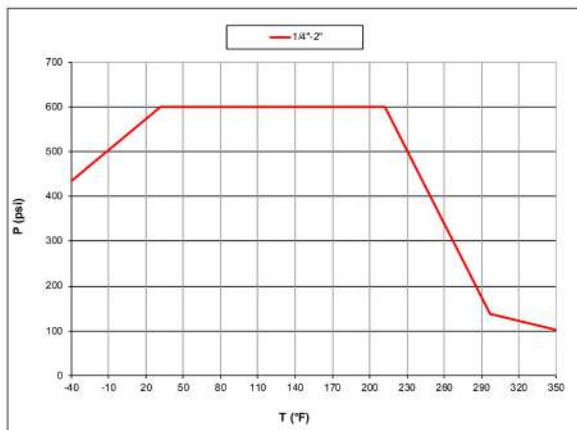

## PRESSURE DROP CHART

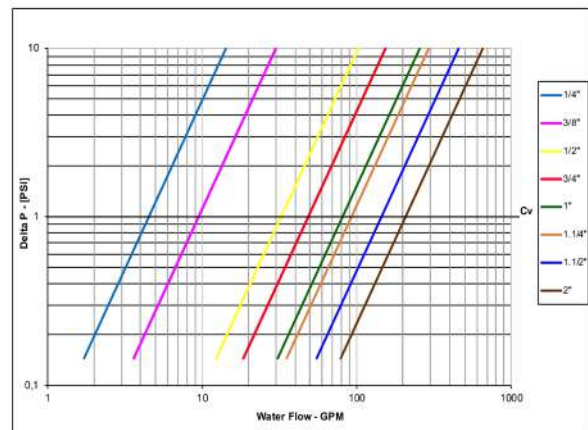



# s.100 3-way 4 seats T-port

Female/Female/Female  
1/4" - 2", ISO 228



EAC

## QUALITY

- Chrome plated brass ball for longer life
- UNI 8858 cycle and torque tests performed

## BODY

- Hot forged sand blasted nickel plated brass body and caps
- 3-way T design allows complete range of flow handling applications
- Copper alloy brass according to EN 12165 and EN 12164 specifications

## STEM

- Maintenance-free, double NBR O-rings at the stem for maximum safety

## SEALING

- Four seats design limits mixture among various fluids in the system
- PTFE seats

## THREADS

- ISO 228 female threads

## FLOW

- Extra port for lowest pressure drop

## WORKING PRESSURE & TEMPERATURE

- See non-shock cold working pressure on chart
- -10°C to +120°C (+15°F to +250°F)
- **WARNING:** freezing of the fluid in the installation may severely damage the valve

## PED DIRECTIVE

- The product described in this document meets the requirements of PED Directive 2014/68/UE and according to art.4 par.3, it does not require CE marking; it cannot be used with dangerous gases in sizes larger than 25mm; it cannot be used with non-dangerous gases in size larger than 32 mm

## APPROVED BY OR IN COMPLIANCE WITH

- EAC – Declaration of conformity (Russia, Kazakhstan, Belarus)

**NOTE:** approvals apply to specific configurations/ sizes only.

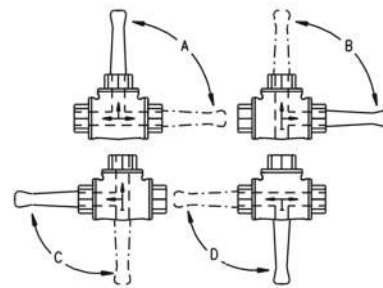

s.100 3-way T port

Each user should perform his own tests to find out the suitability for his particular application. BONOMI INDUSTRIES makes no warranty, express or implied, as to the shape, fit or function of a product for any application. Contact us or consult with your supplier for additional information on the suitability of the BONOMI INDUSTRIES products with your specific field of use.



Part description		Q.ty	Material
1	Nickel plated body	1	CW617N
2	Seat	4	PTFE
3	Chrome plated ball	1	CW617N
4	Nickel plated end-cap	3	CW617N
5	Nickel plated stem O-ring design	1	CW614N
6	Nickel plated nut	1	CW614N
7	O-Ring	2	NBR
8	Screw	1	Steel
9	Red handle	1	Aluminum

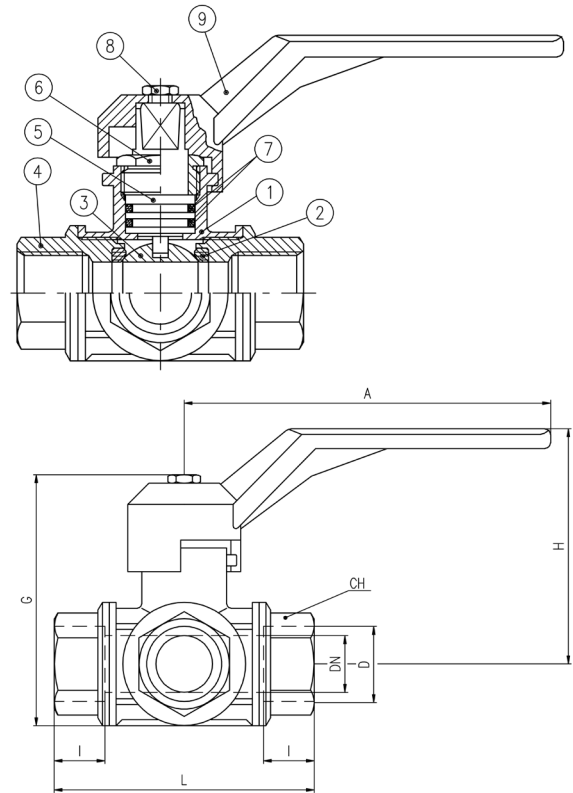

Code	100B00	100C00	100D00	100E00	100F00	100G00	100H00	100I00
D (inch)	1/4"	3/8"	1/2"	3/4"	1"	1 1/4"	1 1/2"	2"
DN (mm)	10	12	14	18	23	29	36	45
I (mm)	19	19	19	23	25	27	31	36
L (mm)	77	77	77	92	104	118	138	162
G (mm)	75	75	75	91	105	115	128	165
A (mm)	125	125	125	145	170	170	170	260
H (mm)	65	65	65	83	96	102	109	139
CH (mm)	22	22	27	34	41	50	57	70
Kv (m <sup>3</sup> /h)	1.5	2.5	3.5	7.0	12	19.5	37	52

**PRESSURE-TEMPERATURE CHART**

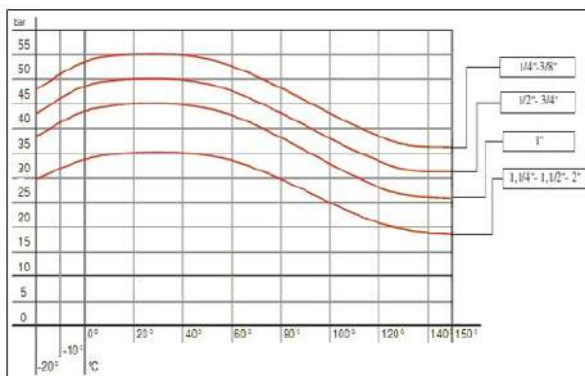

**PRESSURE DROP CHART**

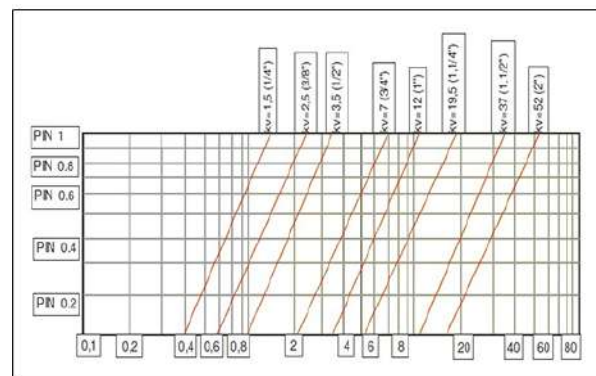



# S.101 3-way 4 seats L-port

Female/Female/Female  
1/4" - 2", ISO 228



EAC

## QUALITY

- Chrome plated brass ball for longer life
- UNI 8858 cycle and torque tests performed

## BODY

- Hot forged sand blasted nickel plated brass body and caps
- 3- way L design allows complete range of flow handling applications
- Copper alloy brass according to EN 12165 and EN 12164 specifications

## STEM

- Maintenance-free, double NBR O-rings at the stem for maximum safety

## SEALING

- Four seats design limits mixture among various fluids in the system
- PTFE seats

## THREADS

- ISO 228 female threads

## FLOW

- Extra port for lowest pressure drop

## WORKING PRESSURE & TEMPERATURE

- See non- shock cold working pressure on chart
- -10°C to + 120°C (+15°F to +250°F)
- **WARNING:** freezing of the fluid in the installation may severely damage the valve

## PED DIRECTIVE

- The product described in this document meets the requirements of PED Directive 2014/68/UE and according to art.4 par.3, it does not require CE marking; it cannot be used with dangerous gases in sizes larger than 25mm; it cannot be used with non-dangerous gases in size larger than 32 mm

## APPROVED BY OR IN COMPLIANCE WITH

- EAC – Declaration of conformity (Russia, Kazakhstan, Belarus)

**NOTE:** approvals apply to specific configurations/ sizes only.

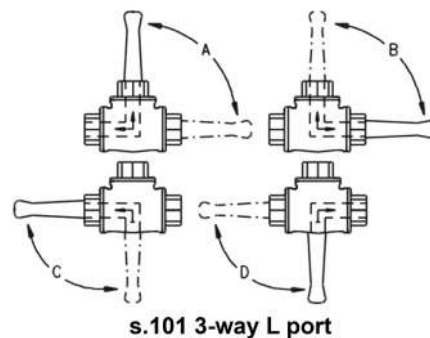



# s.101 XCE101 - 5813

Each user should perform his own tests to find out the suitability for his particular application. BONOMI INDUSTRIES makes no warranty, express or implied, as to the shape, fit or function of a product for any application. Contact us or consult with your supplier for additional information on the suitability of the BONOMI INDUSTRIES products with your specific field of use.



INDUSTRY

Part description		Q.ty	Material
1	Nickel plated body	1	CW617N
2	Seat	4	PTFE
3	Chrome plated ball	1	CW617N
4	Nickel plated end-cap	3	CW617N
5	Nickel plated stem O-ring design	1	CW614N
6	Nickel plated nut	1	CW614N
7	O-Ring	2	NBR
8	Screw	1	Steel
9	Red handle	1	Aluminum

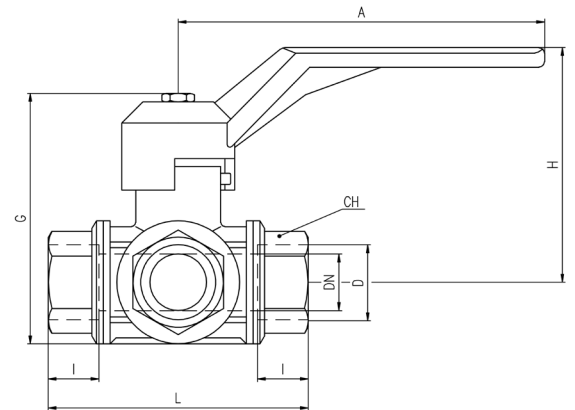
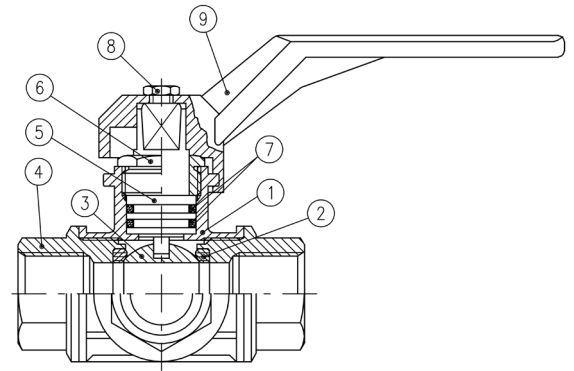

Code	101B00	101C00	101D00	101E00	101F00	101G00	101H00	101I00
D (inch)	1/4"	3/8"	1/2"	3/4"	1"	1 1/4"	1 1/2"	2"
DN (mm)	10	12	14	18	23	29	36	45
I (mm)	19	19	19	23	25	27	31	36
L (mm)	77	77	77	92	104	118	138	162
G (mm)	75	75	75	91	105	115	128	165
A (mm)	125	125	125	145	170	170	170	260
H (mm)	65	65	65	83	96	102	109	139
CH (mm)	22	22	27	34	41	50	57	70
Kv (m <sup>3</sup> /h)	1.5	2.5	3.5	7.0	12	19.5	37	52

## PRESSURE-TEMPERATURE CHART

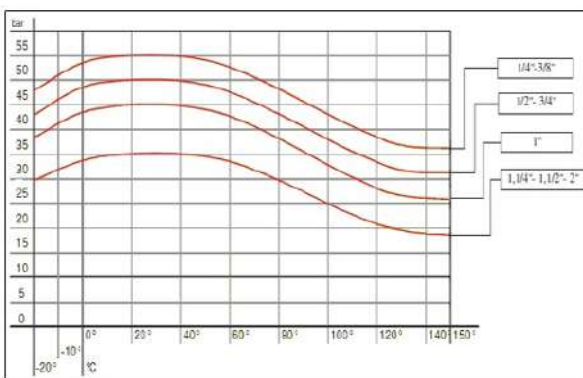

## PRESSURE DROP CHART

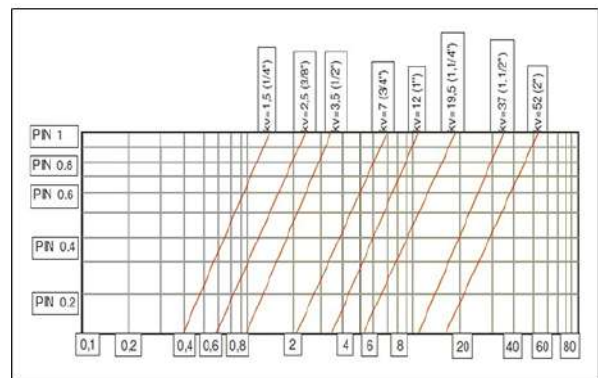



# s.172 motor-oil compact drain ball valve

Specifically responding to a need in the automotive application, s.17 is fitted under the oil sum to ease drainage operations, and furthermore granting a most reliable tightness thanks to its special automatic locking device, even under severe conditions of vibration stress. Frozen drain plug and stripped threads are eliminated, no more contact with hot oil, no messy hands or cloths and reduced oil changing time.

PATENT PENDING



## QUALITY

- 24h 100% seal test guaranteed
- No metal-to-metal moving parts
- No maintenance ever required
- Silicone-free lubricant on all seals
- Screwdriver slot, the slot orientation shows the ball position

## BODY

- Hot forged sand blasted, unplated brass body and cap sealed with metacrylate sealant
- Compact design and solid structure
- Finest brass according to EN 12165 and EN 12164 to prevent corrosion

## STEM

- Blowout-proof AISI 316 stainless steel stem
- Maintenance-free, double FPM O-ring at the stem for maximum safety

## SEALING

- Pure PTFE self-lubricating seats

## THREADS

- M22X1.5 thread with seat for O-ring seal

## HANDLE

- 90° open / close

## WORKING PRESSURE & TEMPERATURE

- 20 bar (300 PSI) non-shock cold working pressure
- -20°C to +130°C (-4°F to +266°F)
- **WARNING:** freezing of the fluid in the installation may severely damage the valve

## UPON REQUEST

- AISI 316 stainless steel ball
- Custom design
- Aluminum body

## PED DIRECTIVE

- The product meets the requirements of PED Directive 2014/68/UE and according to art.4 par.3, it does not require CE marking

## APPROVED BY OR IN COMPLIANCE WITH

- EAC – Declaration of conformity (Russia, Kazakhstan, Belarus)
- RoHS Compliant (EU)

**NOTE:** approvals apply to specific configurations/sizes only.

## OPTIONS

- Elbow version with hose connection
- Allen stem





### STRAIGHT CONFIGURATION

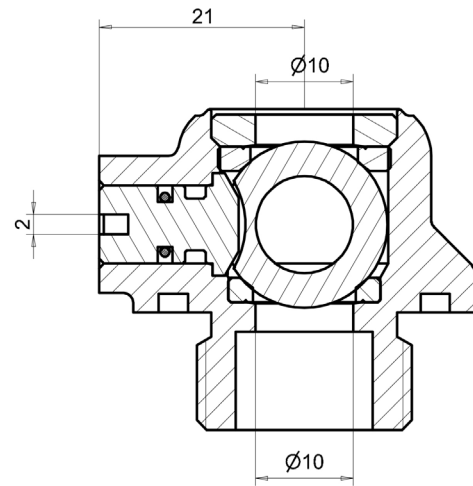
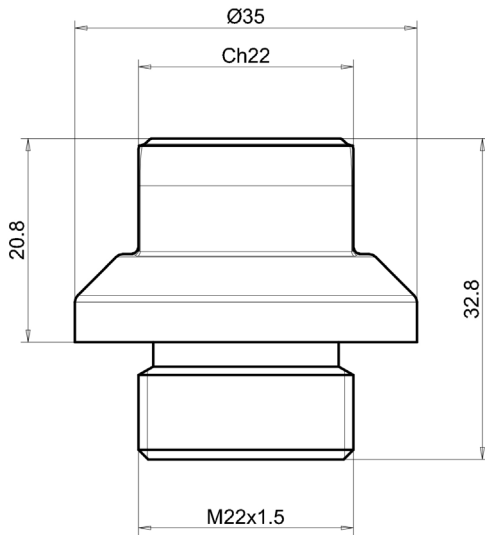

### EXAMPLES OF VALVE DIMENSIONS AND CONFIGURATIONS

#### ELBOW CONFIGURATION

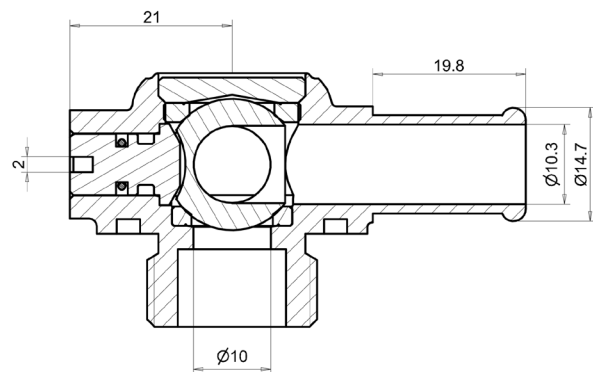
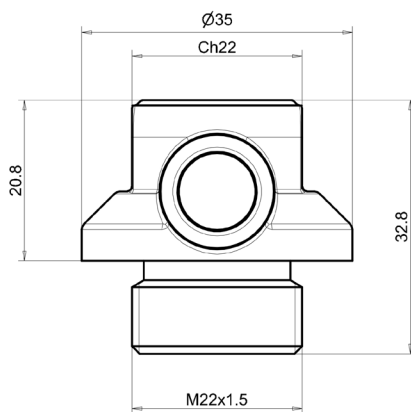



# SNI7352

## Female/Female 1/4" NPT needle valve

The new **RuB** needle valve proves the state of the art of RuB innovation capabilities. This inexpensive valve is designed to ease flow regulation in all applications where drops are counted like gold! The flow chart on reverse compares the **RuB** linear curve performance with competition and it is obvious how by counting the number of turns, the operator can easily adjust flow. All details of the **RuB** needle valve have been optimized to provide utmost performance, reliability and no maintenance. Another "install and forget" **RuB** product.



### QUALITY

- Innovative design
- No maintenance ever required
- Performance guaranteed
- Tamper proof

### BODY

- Hot forged brass body
- One piece body construction

### STEM

- FPM stem seal design
- Handle stop on stem prevents stem blow-out

### THREADS

- Fip x Fip NPT threads

### FLOW

- Easy flow regulation

### WORKING PRESSURE & TEMPERATURE

- 2000 PSI non-shock cold working pressure
- -40°F to +350°F
- WARNING: freezing of the fluid in the installation may severely damage the valve

### UPON REQUEST

- 1/8" NPT threads
- Applications include shut off and throttling for pressure gauges and instruments.

### OPTIONS

- Mip x Fip NPT threads

Part description		Q.ty	Material
1	Unplated valve body	1	CW617N
2	O-Ring	1	FPM
3	Retainer	1	CW617N
4	Handwheel	1	CW617N

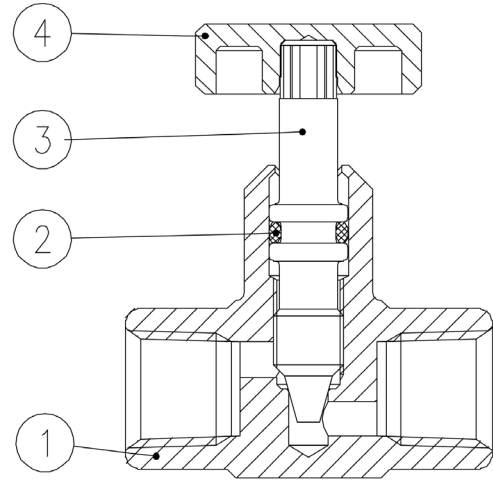

**PRESSURE DROP CHART**

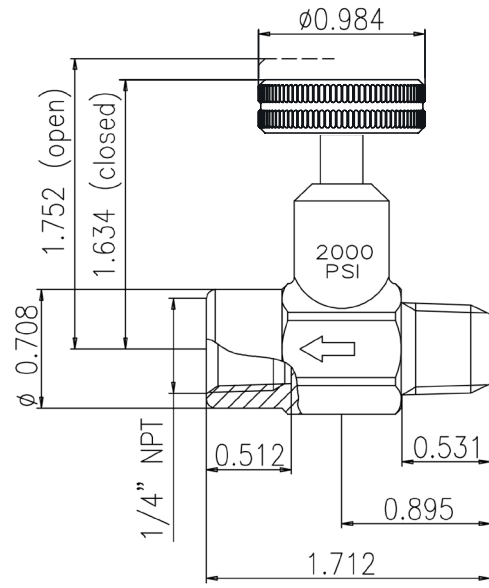
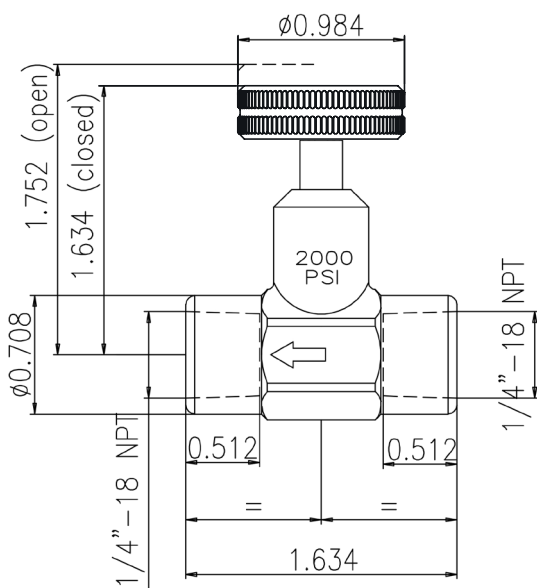
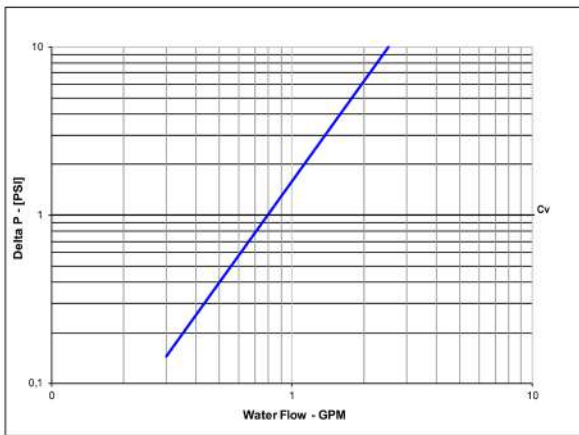



# Instrumentation package

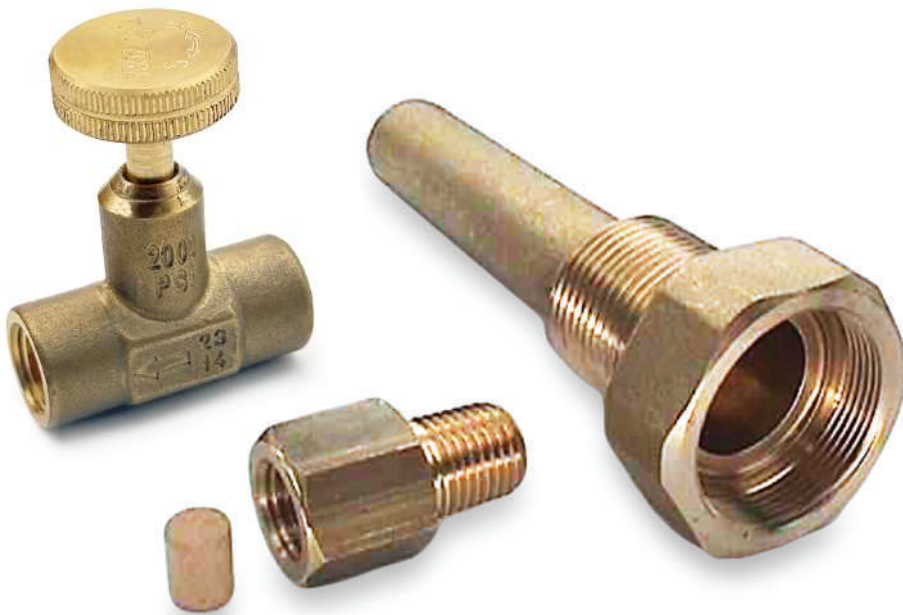

**1/4" VALVE (2000 PSI), #SNI7352**

**1 1/4" THERMOMETER WELL (1000 PSI), #PNI34F2**

**1/4" SNUBBER (1000 PSI), #SNI8722**

# INSTRUMENTAL PACKAGE XCEWSN - 5300

Each user should perform his own tests to find out the suitability for his particular application. BONOMI INDUSTRIES makes no warranty, express or implied, as to the shape, fit or function of a product for any application. Contact us or consult with your supplier for additional information on the suitability of the BONOMI INDUSTRIES products with your specific field of use.

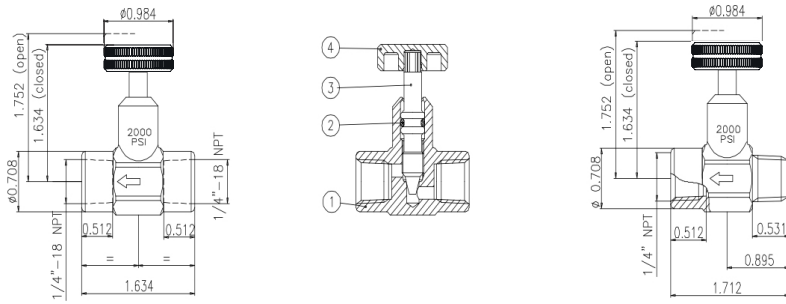

Needle Valve Part description		Q.ty	Material
1	Unplated valve body	1	CW617N
2	O-Ring	1	FPM
3	Retainer	1	CW617N
4	Handwheel	1	CW617N

## NEEDLE VALVE:

2000 PSI (CWP)  
 One piece body construction  
 Forged brass body  
 Fip x Fip NPT threads  
 Temp range -40°F to +350°F  
 FPM stem seal design

Applications include shut off and throttling for pressure gauges and instruments

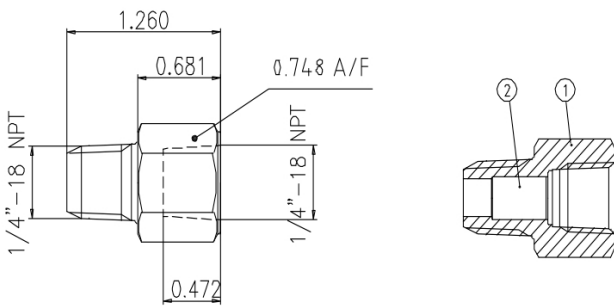

Snubber Part description		Q.ty	Material
1	Unplated valve body	1	CW617N
2	Bronze core	1	Bronze

## SNUBBER:

1000 PSI (CWP)  
 Forged brass with bronze core  
 Temp range -40°F to +350°F  
 Installed on gauges and instruments where pressure pulsations are present.  
 The snubber is used to damp the pulsations, giving more stable readings and reducing instrument wear.

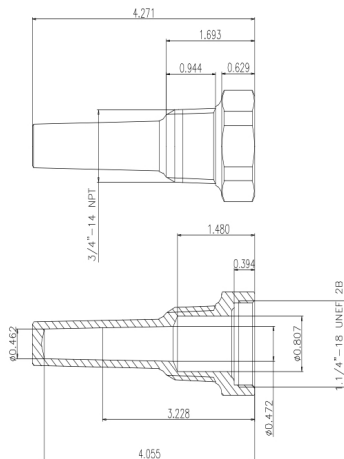

Well Part description		Q.ty	Material
1	Unplated valve body	1	CW617N

## THERMOMETER WELL:

1000 PSI (CWP)  
 Forged brass construction  
 Meets Fed. Spec GG-T-321  
 Meets SAMA RC-17-10  
 Installed on gauges and instruments where pressure pulsations are present. The snubber is used to damp the pulsations, giving more stable readings and reducing instrument wear.







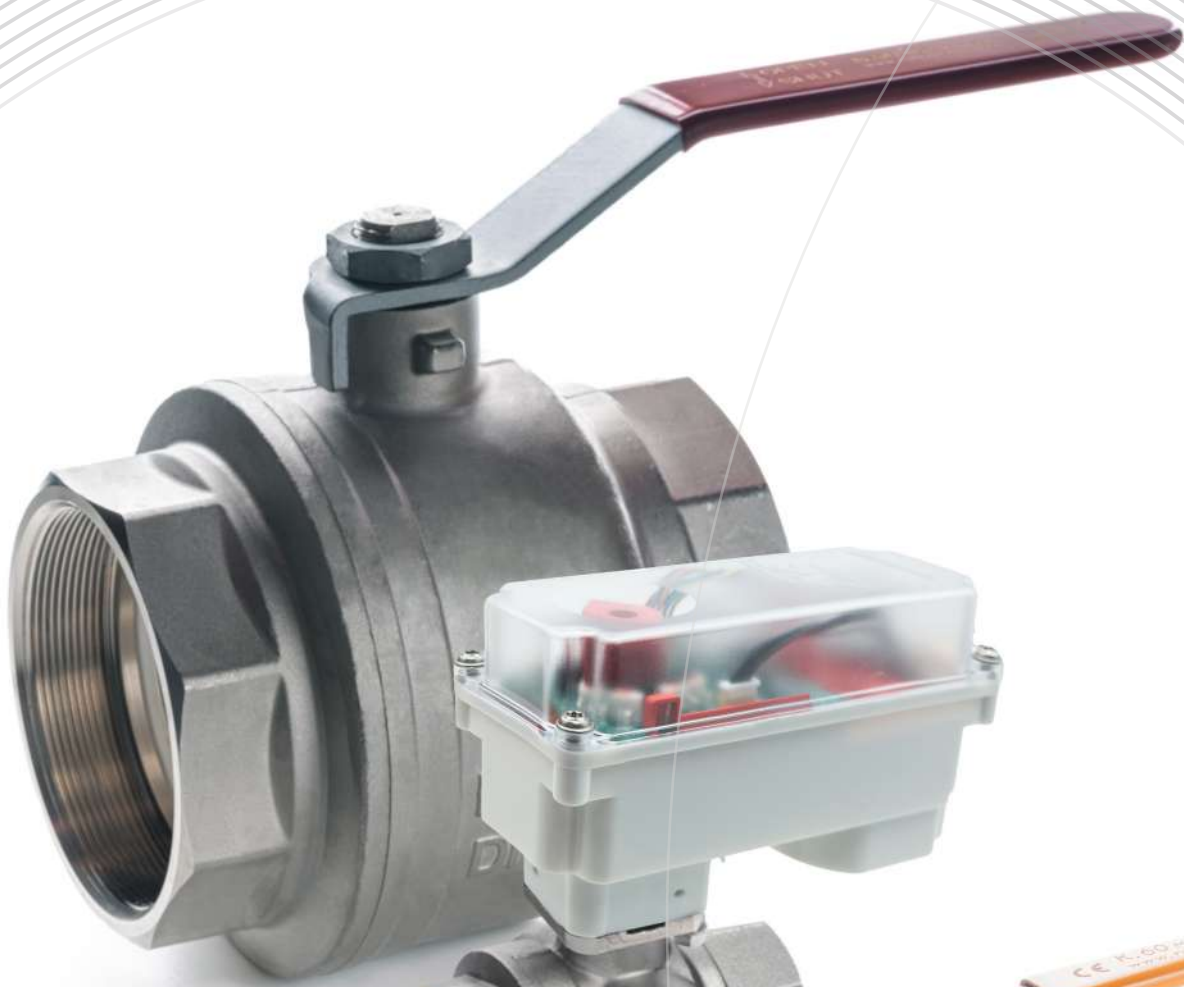

# Application Catalog



ACTUATION



INDUSTRY



PNEUMATIC



GAS



FIREFIGHTING



DRINKING WATER



PLUMBING



ACCESSORIES



Ask for additional information on the whole range of **RuB** products and consult with your supplier for special applications.



**ALL RIGHTS RESERVED | COPYRIGHT© Bonomi Industries Srl 2026**

**Bonomi Industries Srl** endeavors to provide comprehensive information about the installation, maintenance and operation of its products. For more details or clarification, please contact us. **Bonomi Industries Srl** reserves the right to change or modify product design, construction, specifications, materials or the information herein without prior notice and without incurring any obligation to make such changes and modifications on products previously or subsequently sold. Content of this document is proprietary to **Bonomi Industries Srl** and it may not be copied in part or in whole without prior written authorization. Recommendations on application design and material selection are based on available technical data and are offered as suggestions only. Each user should make his/her own tests to determine the suitability for his/her own particular use. **Bonomi Industries Srl** gives no express or implied warranties concerning the form, fit, or function of a product in any application. **Bonomi Industries Srl** does not accept liability for errors or omissions. Any undated reference to a code or standard shall be interpreted as referring to the latest edition.

**Bonomi Industries Srl**, **RuB** and triangles, are all registered trademarks of **Bonomi Industries Srl**. Other logos or trademarks are property of respective owners.

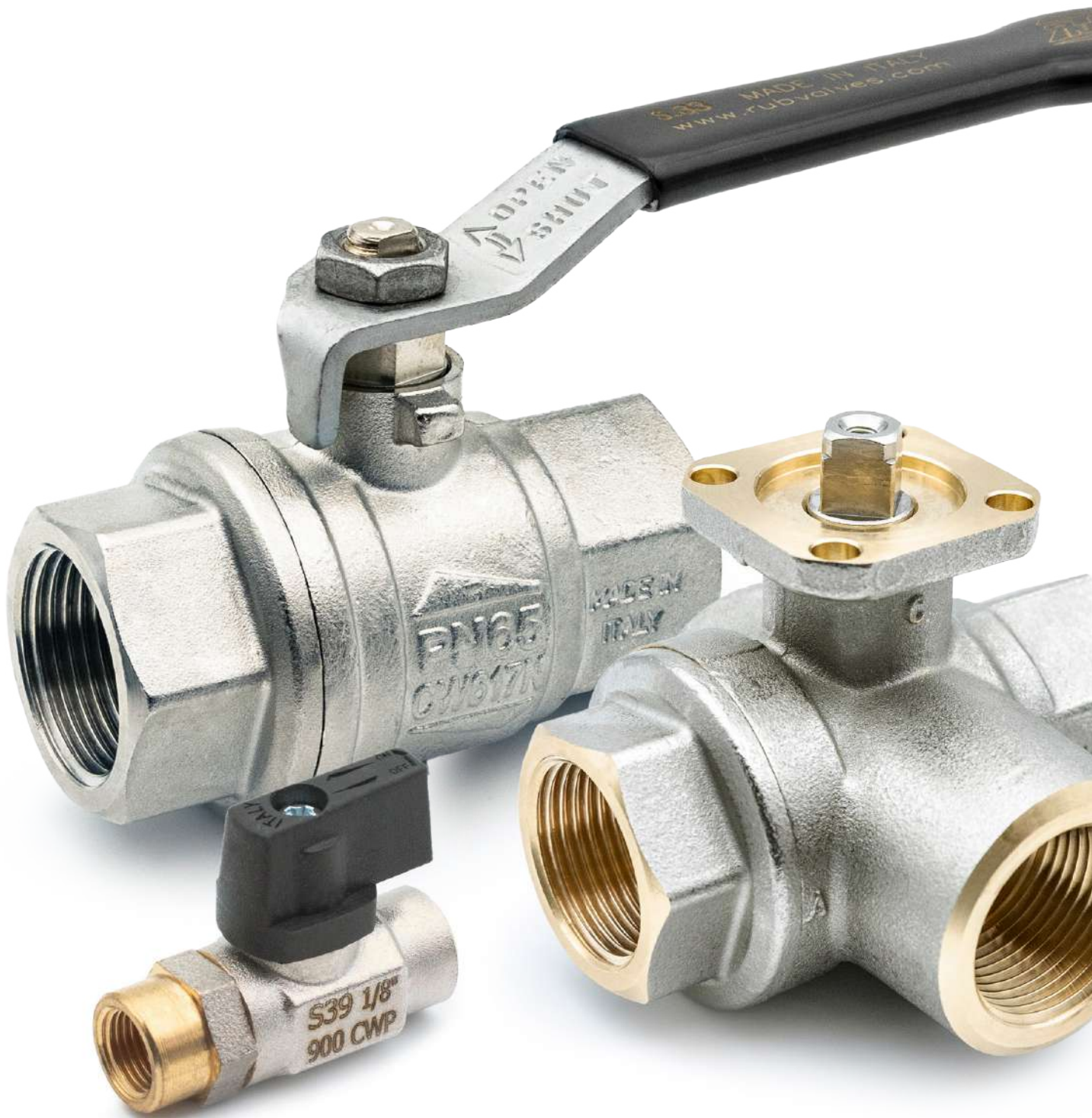



Via Padana Superiore, 29, 25080 Mazzano (BS), Italy  
Tel.: +39 030 212441 - sales@rubvalves.com  
www.rubvalves.com