

GAS CATALOG



Started in 1954 by a young Silvio Bonomi, Bonomi Industries Srl led product and process innovations of the brass valve industry for over 70 years

Our founder's motto was "Quality and trust". This is the legacy we bring forward every day.







About us

Bonomi Industries Srl is an Italian manufacturer of high quality shut-off brass valves, actuators and custom-engineered solutions. Under the RuB brand, its products are globally trusted for their reliability and performance in a variety of applications.

Bonomi Industries Srl is part of Hadron group — a private holding company established in 2018 during the strategic reorganization of Rubinetterie Utensilerie Bonomi (RuB), which also led to the creation of Shedstone, a real estate company — Bonomi Industries Srl continues to grow and innovate. Started in 1954, with entrepreneurial roots tracing back to 1828, the company upholds the values and tradition of a family business while embracing a vision focused towards the future.

Growth at Bonomi Industries Srl is driven by continuous investments in product improvements, advanced machining, assembly, and logistics technologies, as well as expanded manufacturing capabilities, enhanced system interconnectivity, database analysis and strengthened engineering and R&D efforts. At the same time, sustainability — encompassing environmental, social, and governance topics — has always been part of the company's DNA and inspires meaningful actions.

For Bonomi Industries Srl, innovation and responsibility go hand in hand. This commitment shapes a journey aimed at safeguarding the environment, empowering people, and fostering resilient governance for a better tomorrow.



Bonomi Industries Srl turns words into actions for all stakeholders
Scan the QR code to discover our values



Companies

RuB valves and actuators are trusted worldwide, installed across five continents and proven in the most demanding applications.

Production takes place entirely at our headquarters, Bonomi Industries Srl, in Mazzano (Brescia), Italy. Finished products are then distributed globally from Italy and through our international branches. In North America, *RuB, Incorporated* operates from a modern 5.000 sqm (50,000 sqf) facility, handling both assembly and distribution. In Japan, *RuB kk* serves as a strategic presence in a peculiar market.

With a strong global presence, we provide proximity, reliability, and outstanding service to our customers. Our sales team builds lasting partnerships with distributors and OEMs by offering responsive support and technical expertise. Certified, high-quality products, combined with deep knowledge of local cultures and regulations, make Bonomi Industries Srl the trusted partner in fluid control solutions.



Bonomi Industries srl

MAZZANO, BS - ITALY
Manufacturing



RuB, Inc.

SHAKOPEE, MN - USA
Distribution



RuB KK

TOKYO - JAPAN
Distribution



RuB, Inc.
SHAKOPEE, MN - USA
Distribution



Bonomi Industries Srl
MAZZANO, BS - ITALY
Manufacturing



RuB KK
TOKYO - JAPAN
Distribution



Quality

Quality you can trust, proven through generations of experience.

From rigorous incoming goods inspections to double leak testing, 24-72 hour valve assessments, and visual inspections for top markets/applications, Bonomi Industries Srl ensures consistent reliability and precision in every product. Advanced traceability systems, calibrated instruments, and statistical software enhance quality control throughout the production process.

Our dedicated Quality Control team supports continuous monitoring and improvement, ensuring that each production batch meets exactly applicable standards. Paired with robust testing protocols and expert technical support, we deliver solutions designed to meet the most challenging applications.



Approved by Lloyd's Register Quality Assurance:

ISO 9001:2015 (Quality Management) since 1998.

ISO 14001:2018 (Environmental Management System) since 2021.

ISO 45001:2018 (Occupational Health & Safety) since 2021.



Environment: Air and water are filtered and recovered. Use of recycled environment-friendly packaging materials. Scrap is recycled.



Product Quality Assessment: recognized by certifying bodies in all major industrialized countries worldwide



Safety: compliance with the provisions of decree 81/2008 for the safety system, extensive staff training, and continuous monitoring



Customized products developed by the Engineering Center



In compliance with the **PED Directive** since 2002



Quality you can trust

See our quality process in action/Experience every step of our quality process





Sustainability

Sustainability has always been a necessity, not a choice. The adoption of sustainable practices at corporate level lays the foundation for creating virtuous cycles that inspire future generations.

Our commitment is stronger than ever, and we're proud to share with you here below figures that mark the tasks we focus on our actions, achievements, and the vision we have for the future. Localized production of electricity is now a reality and we have not been shy with our investments towards clean renewable energy.

Companies are finally waking up to producing their own electricity. Aside from covering the needs of our production manufacturing facility with through solar panels, we constantly reduce energy consumption by investing in smart technology and minimizing heavy material handling.

The diligence with which we strive to make our process and products less impactful on the environment is confirmed by the certifications awarded by international bodies, in particular ISO 14001:2018 and the "silver" medal in the EcoVadis sustainability assessment.

HOW WE WALK THE TALK.

100% of our brass ball valves prevent unnecessary waste – lifetime guaranteed

96% manufacturing scrap is reused

30% of energy comes from our own renewable sources

100% cooling waters are recovered and reused



Together, safeguarding our Planet
Learn more about our initiatives.







OEM

Every year, OEMs all over the world rely on RuB custom solutions to reduce leaks, equipment breakages and production downtime. We're heavily invested in OEM customizations with custom-made machinery for innovative products and solutions.

We have proven expertise in solving technical and operational challenges for leading boilers, heat pumps and burners manufacturers, LPG gas tank and system manufacturers, manufacturers of watering systems, fire protection, refrigeration, HVAC manufacturers, marine applications with shipbuilders, compressors, tanks, machine tools manufacturers, filtration, chemical, food processing and pharmaceutical companies.

We are intrigued to learn about your obstacles and bring your custom, top shelf solution to life.

PRIVATE LABEL

We strive to meet the needs of our customers in every way possible. And we do so not only through specifically designed, engineered and manufactured OEM products, but also by customizing standard RuB ball valves.

The possible branding options to choose from include:

- Changing the lever marking to the customer's trademark
- Packing with a custom label
- Customized handle colors and materials
- Customized valve fittings
- Dedicated valve body stamping
- Special marking on the valve body
- Custom installation instructions



OEM solutions, custom made for you

OEMs have a Partner to solve their challenges and develop new products





Certifications

We are proud to offer 100% made-in-Italy shut-off brass valves, actuators, and OEM-engineered products, all manufactured in our ISO 9001:2015 certified headquarters in Brescia, Italy. Since adopting this quality management system in 1992 under Lloyd's Register, we have continuously improved product reliability, performance and traceability.

Our certifications, granted by leading global laboratories and agencies, demonstrate compliance with the highest standards for major applications and markets. Supported by rigorous testing and state of art technology, our products meet the demanding requirements of top manufacturers and distributors worldwide.

PRODUCT TYPE APPROVALS

 Deutsche Vereinigung des Gas und Wasserfaches e.V. Technisch-wissenschaftlicher Verein		 General Directorate of Civil Defence	
 Deutsche Vereinigung des Gas und Wasserfaches		 The Australian Gas Association	
 Deutsche Vereinigung des Gas und Wasserfaches Hygiene		 OSHA Compliant	
 Schweizerischer Verein des Gas und Wasserfaches		 Factory Mutual Research Corporation	
 Attestation de Conformité Sanitaire		 Underwriter Laboratories Inc.	
 ARGB-KVBG		 CRN-TSSA	
 Water Regulations Advisory Scheme		 CSA International for Drinking Water to NSF/ANSI 61- NSF/ANSI 372	
 British Standards Institution		 CSA - Canadian Standards Association	
 Kiwa KUKreg4		 KSFD -Kuwait Fire Service Directorate	
 Ri.se. / Boverket		 LIA - L.P Gas Instruments Inspections Association	
 Kiwa - Swedcert			

COMPLIANCES

 ROHS		 PED 2014/68/UE by ICIM (0425)	PED
 Reach declaration	Reach	 Декларация соответствия	EAC



We developed and constantly innovate strict protocols and processes
Discover all the certifications and awards received from international bodies



PATENTED
NO. 1421306

↑ OPEN
↓ SHUT

RuB valve features

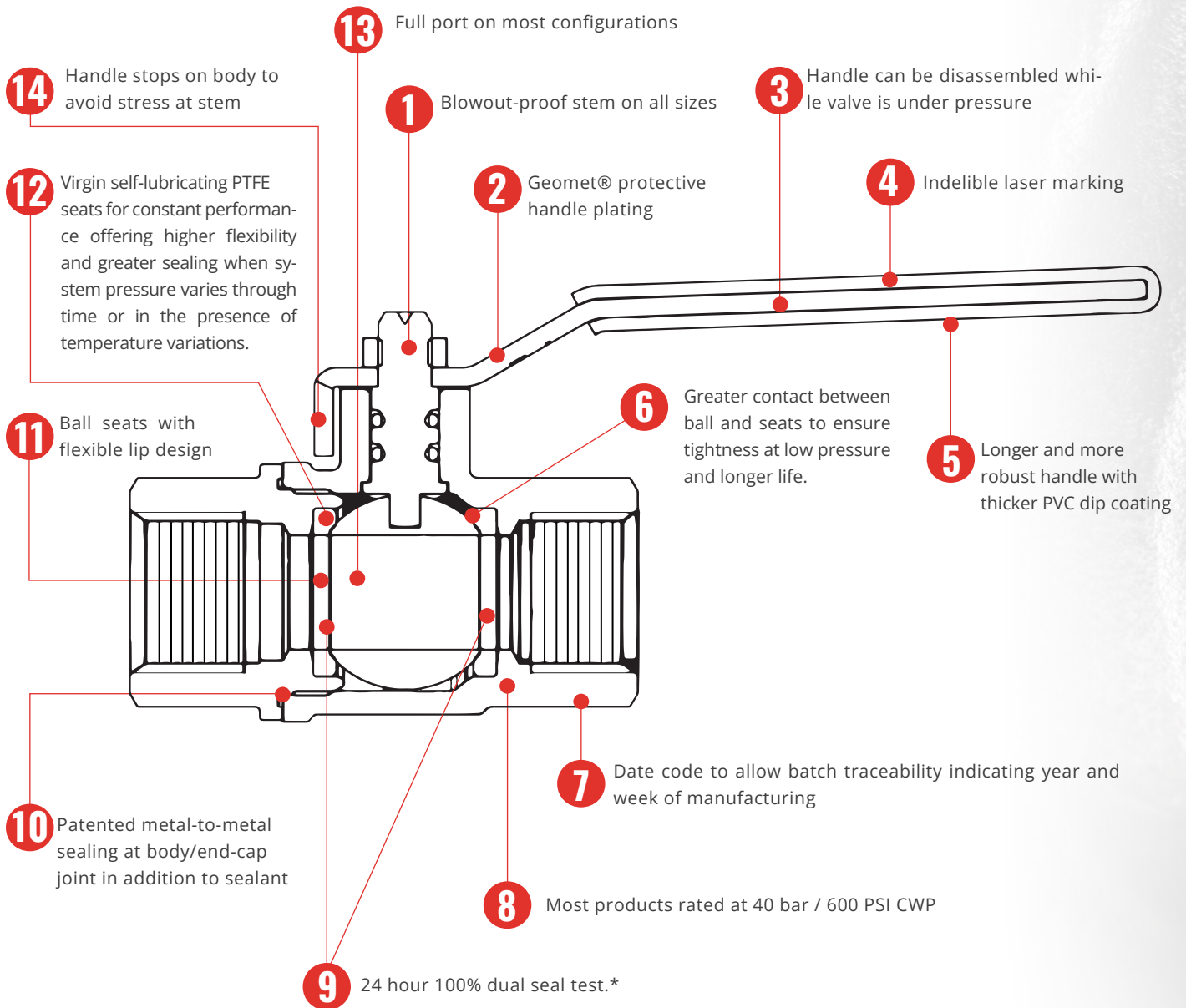

RuB seal test

Valve in half open position is pressurized at 6 bar (87 psig), then closed, trapping compressed air in between ball seats and stem sealing. After adequate preset time, based upon valve size, any leaks are verified using extremely accurate electronic sensors and any defective valve is automatically rejected; all valves passing this initial seal test are filled with compressed air again and remain closed and under pressure for minimum 24 hours; after 24 hours, the valves go back again under the same accurate a new set of electronic pressure sensors and any leaking valve is automatically rejected.

* Certain products are not suitable for double seal test



Our solutions come with an added benefit: maximizing your revenue
Scan the QR code to discover our products



GAS

Our valves are chosen to ensure gas metering plants, boilers and burners, HVAC systems and water heaters have zero gas leakages. We are chosen to handle even refinery, chemical and pharmaceutical gases like methane, propane and butane. Each of our gas valves is pluri-awarded and certified because we manufacture them to perform flawlessly with any gas type, in any environment and under any local government regulation





k.60 1/4" - 2" EN 10226-1, heavy duty DIN 16722 M3	Page 20
s.80 NPT 3/4" - 2" gas cock with tamper proof locking	Page 22
s.80 NPT surepass 3/4" - 1" 175 PSI bypassing gas meter valve	Page 24
s.8042 NPT 3/4" - 2" with tamper proof locking	Page 26
s.8043 NPT dielectric 3/4" - 1 1/4" with tamper proof locking	Page 28
s.82 NPT 1/2" - 2" side drain	Page 30
k.84 1/4" - 2" EN 10226-1, DIN 16722 M3	Page 32
S.84 IR6 1/2" - 1" EN 10226-1	Page 34
s.84 EN331 1/4" - 4" EN 10226-1	Page 36
s.84 EN331 M/F 1/4" - 4" EN 10226-1	Page 38
s.84 BSPT 1/4" - 4"	Page 40
s.84 BSPT MF 1/4" - 2"	Page 42
s.84 BSPT T-handle 1/4" - 1 1/2"	Page 44
s.92 NPT 1/4" - 4" packing gland	Page 46
s.92 NPT M/F 1/4" - 4" packing gland	Page 48
s.95 NPT 1/4" - 4"	Page 50
s.95 NPT T-handle 1/4" - 2"	Page 52
s.95 NPT nickel plated 1/4" - 4"	Page 54
s.128A 3/4" Y-strainer	Page 56
s.195 NPT 3/8" - 1" standard port gas cock	Page 58
s.195 & flare flare 37° by solder end 1/2" - 3/4", standard port	Page 60



k.60

Female/Female
1/4" - 2"

EN 10226-1, heavy duty DIN 16722 M3

HIGH TEMPERATURE RESISTANCE

Now approved for HTB use (Hochtemperaturbeständigkeit)

Class B 0,1 (0,1 bar @650°C for at least 30 minutes).



H2 READY: product approved in EU acc.to EN331 (sizes 1/4" to 2") for the 1st, 2nd and 3rd gas families, therefore compatible with hydrogen use up to 50% in the gas mixture, as established in the 1st gas family of the EN437 (ref. G110)



QUALITY

- 24h 100% seal test guaranteed
- Dual sealing system allows valve to be operated in either direction making installation easier
- No metal-to-metal moving parts
- No maintenance ever required
- Handle clearly shows ball position
- Silicone-free lubricant on all seals
- Chrome plated brass ball for longer life
- Handle stops on body to avoid stresses at stem

BODY

- Hot forged sand blasted, nickel plated brass body and cap sealed with Loctite® or equivalent thread sealant
- Valve length according to DIN 16722 M3 for sizes from 3/8" to 2" (DN10 to DN50). Size 1/4" (DN 8) complies to DIN 3202 M3.
- Finest brass according to EN 12165 and EN 12164 specifications

STEM

- Blowout-proof nickel plated brass stem
- Maintenance-free, double FPM O-rings at the stem for maximum safety

SEALING

- Pure PTFE self-lubricating seats with flexible-lip design

THREADS

- EN 10226-1, ISO 228 parallel female by female threads

FLOW

- 100% full port for maximum flow

HANDLE

- Geomet® carbon steel handle with thick PVC dip coating. Handle coating offers both thermal and electrical protection
- **WARNING:** do not exceed reasonable temperature and/or electrical load

WORKING PRESSURE & TEMPERATURE

- 65 bar (940 PSI) up to 1"; 40 bar (600 PSI) over 1" non-shock cold working pressure
- -40°C to +170°C (-40°F to +350°F)
- For use with dangerous fluids temperature rating is -20°C to +60°C (-4°F to +140°F) and pressure rating is 5 bar (72 PSI) / **HTB** Class B 0,1
- **WARNING:** freezing of the fluid in the installation may severely damage the valve

UPON REQUEST

- Stainless steel ball (1.4401 / AISI 316)
- Glass filled PTFE seals
- Custom design

PED DIRECTIVE

- Assessment according to Pressure Equipment Directive 2014/68/UE module B+D by ICIM (0425)

APPROVED BY OR IN COMPLIANCE WITH

- SVGW (Switzerland)
- RoHS Compliant (EU)
- DVGW (Germany) – MOP 5 B 0,1
- EAC – Declaration of conformity (Russia, Kazakhstan, Belarus)

NOTE: approvals apply to specific configurations/sizes only.

OPTIONS

- Stem extension
- Oval lockable handle **1**
- **RuB** memory stop designed to be installed with our stubby handle **2**
- Stainless steel handle (1.4016 / AISI 430) **3**
- Stubby handle **4**
- T-handle **5**
- Patented locking device



K.60 XCEK60 - 5813

Each user should perform his own tests to find out the suitability for his particular application. BONOMI INDUSTRIES makes no warranty, express or implied, as to the shape, fit or function of a product for any application. Contact us or consult with your supplier for additional information on the suitability of the BONOMI INDUSTRIES products with your specific field of use.



Part description	Q.ty	Material
1 Nickel plated body	1	CW617N
2 Seat	2	PTFE
3 Chrome plated ball	1	CW617N
4 Nickel plated end-cap	1	CW617N
5 Nickel plated stem O-ring design	1	CW617N
6 Geomet® nut	1	C4C (EN10263-2)
7 O-Ring	2	FPM
8 Yellow PVC coated Geomet® steel handle	1	DD11 (EN10111)

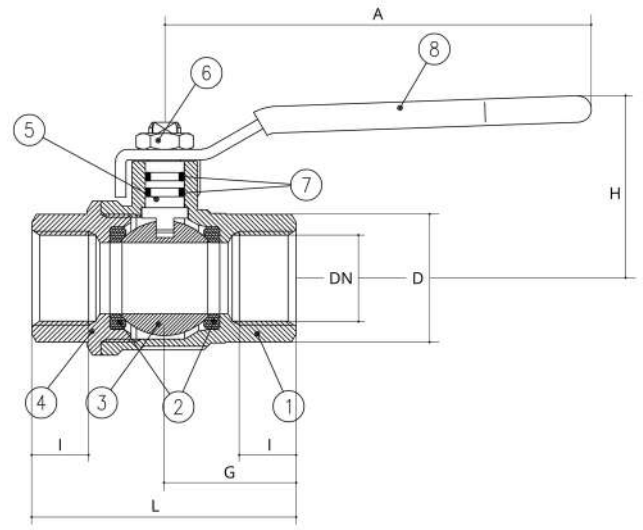

1 1/4"-2" hollow ball

Compliant to CE 2014/68/UE product Equipment category III Module B+D

Code	S60B05	S60C05	S60D05	S60E05	S60F05	S60G05	S60H05	S60I05
D (inch)	1/4"	3/8"	1/2"	3/4"	1"	1 1/4"	1 1/2"	2"
DN (mm)	8	10	15	20	25	32	40	50
I (mm)	14	14	16.5	19	22	25	26	29
L (mm)	50	60	75	80	90	110	120	140
G (mm)	25,5	25,5	30,5	37	45,5	52	59	67,5
A (mm)	82	82	100	120	120	158	158	158
H (mm)	40	40	43	51	55,5	75	81	88
CH (mm)	22	22	27	32	41	50	55	70
PN (bar)	65	65	65	65	65	40	40	40
Kv (m3/h)	4,1	8,7	28	60	100	95	179	233

Ball valves are marked CE on handle from 1 1/4" to 2" as follow:
CE 0425 cat IIIB+D PS: 5 GAS TS1: -20°C TS2: +60°C

PRESSURE-TEMPERATURE CHART

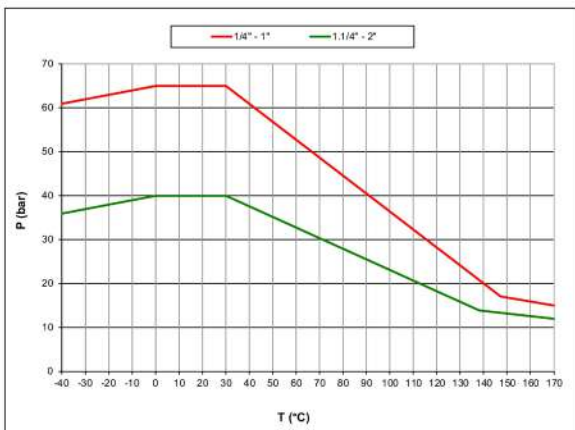

PRESSURE DROP CHART

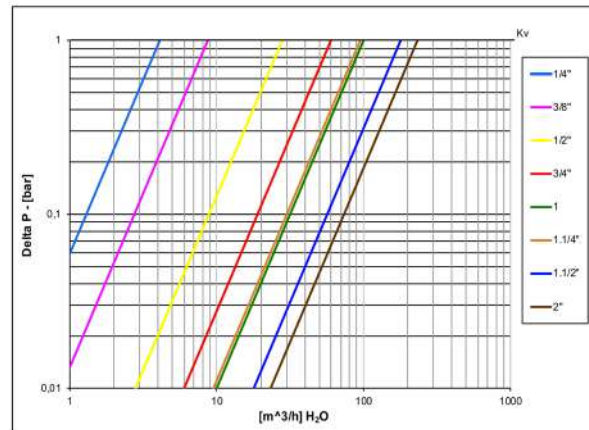



s.80 NPT

Female/Female
3/4" - 2"
gas cock with tamper, proof locking



QUALITY

- 24h 100% seal test guaranteed
- Dual sealing system allows valve to be operated in either direction making installation easier
- No metal-to-metal moving parts
- No maintenance ever required
- Cover clearly shows ball position
- Silicone-free lubricant on all seals
- Handle stops on body to avoid stresses at stem
- Chrome plated brass ball for longer life

BODY

- Hot forged sand blasted, unplated brass body and cap sealed with Loctite® or equivalent thread sealant
- Special design to combine newest technologies in valve and traditional gascock requirements
- Finest brass according to EN 12165 and EN 12164 specifications

STEM

- Blowout-proof unplated brass stem
- Maintenance-free, double FPM O-rings at the stem for maximum safety

SEALING

- Pure PTFE self-lubricating seats with flexible-lip design

THREADS

- NPT taper ANSI B.1.20.1 female by female threads

FLOW

- Full port to DIN 3357 for maximum flow

HANDLE

- Hot forged brass tamper proof locking

WORKING PRESSURE & TEMPERATURE

- 600 PSI (40 bar) non-shock cold working pressure
- 250 PSI (17 bar) non-shock working pressure for LP-Gas
- -40°F/ +350°F (-40°C / +170°C)
- **WARNING:** freezing of the fluid in the installation may severely damage the valve

UPON REQUEST

- Painted gray
- * For sales within EU: CE marking needed, please contact us

APPROVED BY OR IN COMPLIANCE WITH

- Underwriters Laboratories (United States, Canada)
- Guide YSDT: LP-Gas shut-off valve
- Guide YRBX: Flammable liquid shut-off valve
- Guide YRPV: Gas shut-off valve for use with natural and manufactured gases
- Guide MHKZ: No. 6 oil at 250°F
- EAC – Declaration of conformity (Russia, Kazakhstan, Belarus)
- Canadian standards Association (United States, Canada)
- RoHS Compliant (EU)
- Kuwait Fire Service Directorate (Kuwait)

NOTE: approvals apply to specific configurations/sizes only.

OPTIONS

- Male by female NPT threads



s.80 NPT XCES80 - 6012

Each user should perform his own tests to find out the suitability for his particular application. BONOMI INDUSTRIES makes no warranty, express or implied, as to the shape, fit or function of a product for any application. Contact us or consult with your supplier for additional information on the suitability of the BONOMI INDUSTRIES products with your specific field of use.



Part description	Q.ty	Material
1 Unplated NPT body	1	CW617N
2 Seat	2	PTFE
3 Chrome plated ball	1	CW617N
4 Unplated NPT end-cap	1	CW617N
5 Unplated stem O-ring design	1	CW617N
6 Stainless steel screw	1	1.4301 / AISI304
7 Unplated lockwing	1	CW617N
8 O-Ring	2	FPM
9 Washer (from 3/4" to 2")	1	PTFE glass filled 25%

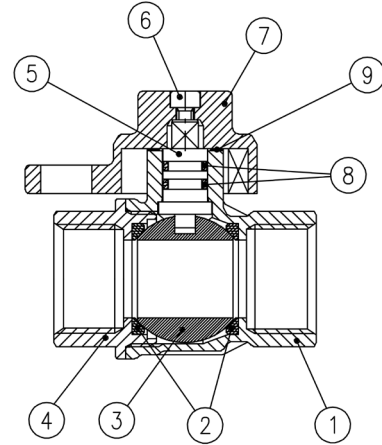

1 1/4"-2" hollow ball

For sales within EU: CE marking needed, please contact us

Code	S80E41	S80F41	S80G41	S80H41	S80I41
D (inch)	3/4"	1"	1 1/4"	1 1/2"	2"
DN (inch)	0.748	0.945	1.181	1.496	1.890
I (inch)	0.669	0.827	0.906	0.906	1.043
L (inch)	2.520	3.189	3.661	4.016	4.764
G (inch)	1.260	1.594	1.831	2.008	2.382
A (inch)	1.142	1.142	1.209	1.209	1.209
H (inch)	1.831	1.988	2.559	2.795	3.071
M (inch)	0.492	0.492	0.472	0.472	0.472
N (inch)	0.449	0.449	0.563	0.563	0.563
CH (inch)	1.220	1.575	1.929	2.126	2.697
Cv (GPM)	48.5	80.9	92.4	144.4	206.8

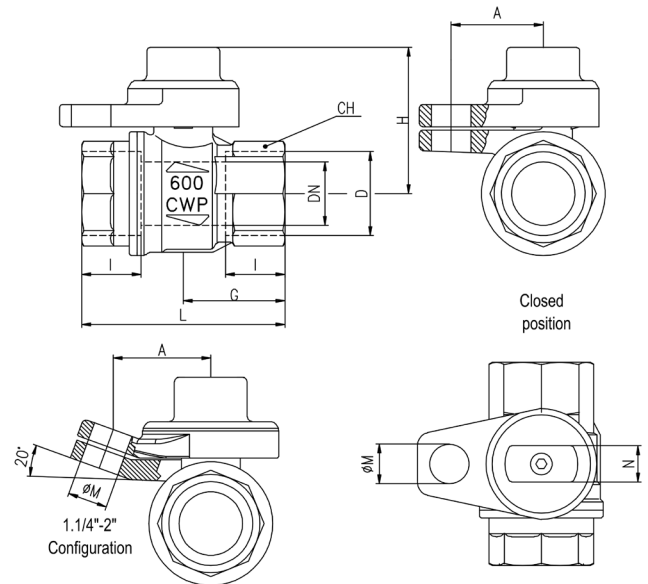

DN shows the nominal flow diameter. Actual flow diameter complies with full port DIN 3357 part 4.

PRESSURE-TEMPERATURE CHART

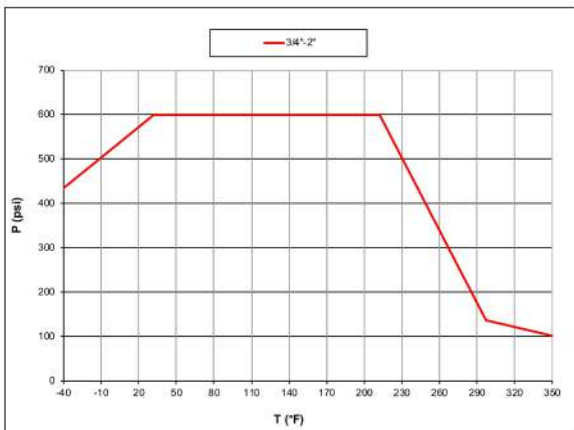

PRESSURE DROP CHART

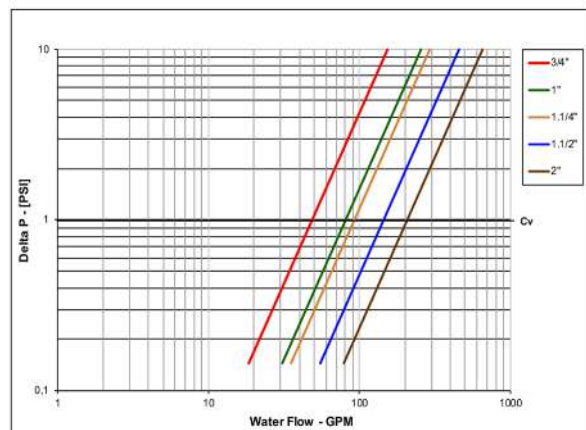



s.80 NPT surepass

3/4" - 1"
175 PSI
bypassing gas meter valve

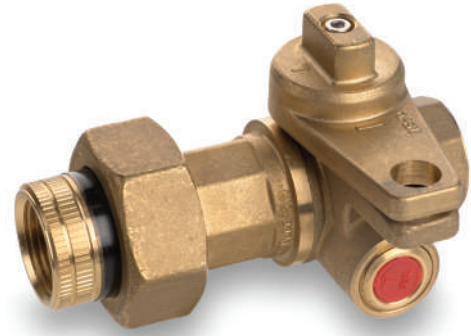

One quick turn switches valve from normal metered flow to bypass mode for rapid on-line servicing of meter or regulator.



QUALITY

- No metal-to-metal moving parts
- No maintenance or lubrication ever required
- Every valve production tested twice for internal or external leakage
- Meets all applicable parts to DoT 192
- Customer service never interrupted
- Chrome plated brass ball
- Gas theft discouraged by plastic security plug in bypass port and port inaccessible when barrel lock in use

BODY

- Rust-proof forged brass body, ball, stem and lockwing

STEM

- Maintenance-free, double FPM O-rings at the stem for maximum safety, eliminate gas emissions

SEALING

- Pure PTFE seats with flexible-lip design

THREADS

- NPT taper ANSI B1.20.1 female by dielectric union female threads

FLOW

- Full port to DIN 3357 for maximum flow
- Full 100 SCFH gas flow during bypassing

HANDLE

- Tamper proof lockwing
- Single lever operation for positive switch from metering to bypassing

WORKING PRESSURE & TEMPERATURE

- 175 PSI non-shock cold working pressure
- -40°F/ +350°F
- **WARNING:** freezing of the fluid in the installation may severely damage the valve

APPROVED BY OR IN COMPLIANCE WITH

- Canadian standards Association (United States, Canada)
- EAC – Declaration of conformity (Russia, Kazakhstan, Belarus)
- RoHS Compliant (EU)

NOTE: approvals apply to specific configurations/sizes only.

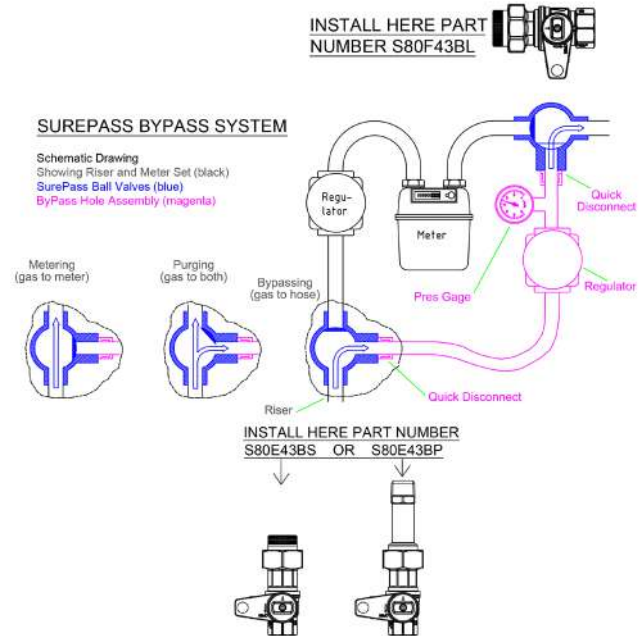

Tamper proof seal

OPTIONS

- Painted gray
- By-pass hose assembly
- Dielectric union end long or short pattern

s.80 NPT SUREPASS XCES80SP - 5813

Each user should perform his own tests to find out the suitability for his particular application. BONOMI INDUSTRIES makes no warranty, express or implied, as to the shape, fit or function of a product for any application. Contact us or consult with your supplier for additional information on the suitability of the BONOMI INDUSTRIES products with your specific field of use.



GAS

Part description		Q.ty	Material
1	Sand blasted body	1	CW617N
2	Seat	2	PTFE glass filled 5-15%
3	Chrome plated ball	1	CW617N
4	Sand blasted end-cap	1	CW617N
5	Nut	1	CW617N
6	NPT female tail piece	1	CW617N
7	O-Ring	1	FPM
8	Stem O-Ring design	1	CW617N
9	O-Ring	2	FPM
10	Washer	1	PTFE glass filled 25%
11	Sand blasted lockwing	1	CW617N
12	Stainless steel screw	1	1.4301 / AISI304
13	Plug	1	CW617N
14	Security plug	1	Polystyrene
15	O-Ring	1	FPM
16	Insulation (for 3/4")	1	Polyamide

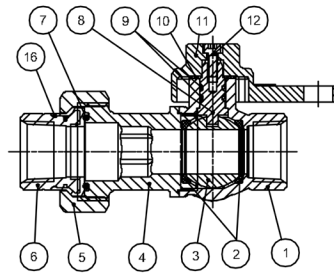

S80E43BS

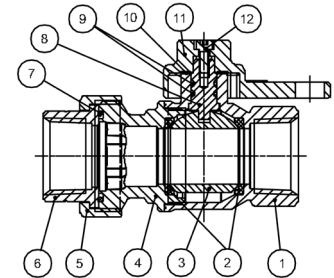

S80F43BL

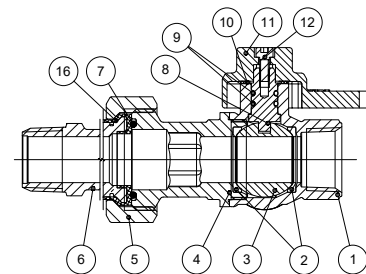

S80E43BP

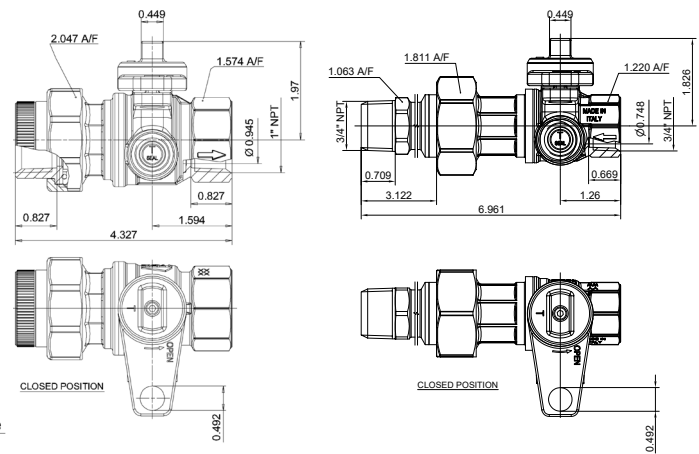
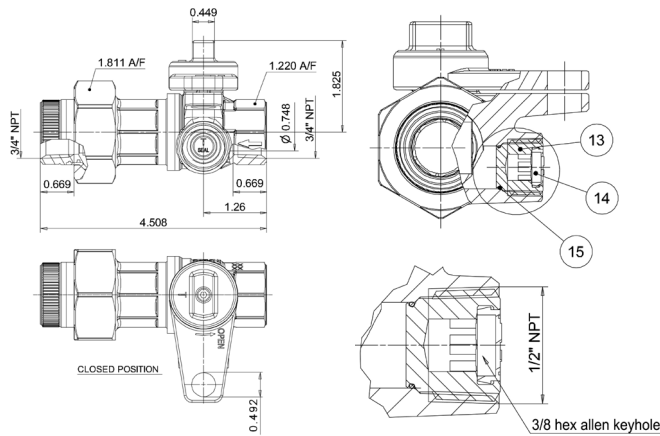

DN shows the nominal flow diameter. Actual flow diameter complies with full port DIN 3357 part 4.

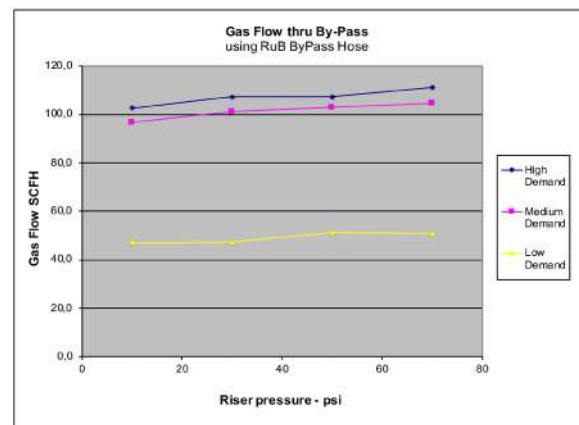



s.8042 NPT

**Male/Female
3/4" - 2"
with tamper proof lockwing**

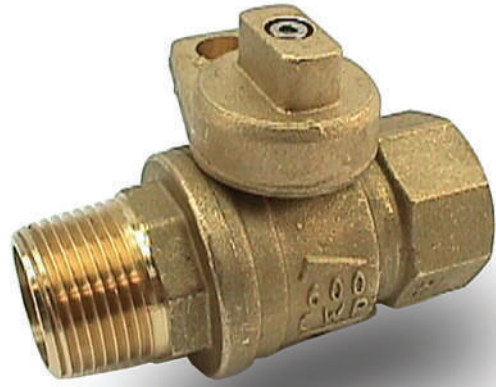

QUALITY

- 24h 100% seal test guaranteed
- Dual sealing system allows valve to be operated in either direction making installation easier
- No metal-to-metal moving parts
- No maintenance ever required
- Cover clearly shows ball position
- Silicone-free lubricant on all seals
- Chrome plated brass ball for longer life
- Handle stops on body to avoid stress at stem

BODY

- Hot forged sand blasted, unplated brass body and cap sealed with Loctite® or equivalent thread sealant
- Special design to combine newest technologies in valve and traditional gascock requirements
- Finest brass according to EN 12165 and EN 12164 specifications

STEM

- Blowout-proof nickel unplated brass stem
- Maintenance-free, double FPM O-rings at the stem for maximum safety

SEALING

- Pure PTFE self-lubricating seats with flexible-lip design

THREADS

- NPT taper ANSI B.1.20.1 male by female threads

FLOW

- Full port to DIN 3357 for maximum flow

OPTIONS

- Female by female NPT threads

HANDLE

- Hot forged brass tamper proof locking

WORKING PRESSURE & TEMPERATURE

- 600 PSI (40 bar) non-shock cold working pressure
- 250 PSI (17 bar) non-shock working pressure for LP-Gas
- -40°F to +350°F (-40°C / +170°C)
- **WARNING:** freezing of the fluid in the installation may severely damage the valve

UPON REQUEST

- * For sales within EU: CE marking needed, please contact us

APPROVED BY OR IN COMPLIANCE WITH

- Canadian standards Association (United States, Canada)
- EAC – Declaration of conformity (Russia, Kazakhstan, Belarus)
- RoHS Compliant (EU)
- Underwriters Laboratories (United States, Canada):
 - Guide YSDT: LP-Gas shut-off valve
 - Guide YRBX: Flammable liquid shut-off valve
 - Guide YRPV: Gas shut-off valve for use with natural and manufactured gases
 - Guide MHKZ: No. 6 oil at 250°F

NOTE: approvals apply to specific configurations/sizes only.

s.8042 NPT XCES8042 - 6012

Each user should perform his own tests to find out the suitability for his particular application. BONOMI INDUSTRIES makes no warranty, express or implied, as to the shape, fit or function of a product for any application. Contact us or consult with your supplier for additional information on the suitability of the BONOMI INDUSTRIES products with your specific field of use.



Part description		Q.ty	Material
1	Unplated NPT body	1	CW617N
2	Seat	2	PTFE
3	Chrome plated ball	1	CW617N
4	Unplated NPT male end-cap	1	CW617N
5	Unplated stem O-ring design	1	CW617N
6	Stainless steel screw	1	1.4301 / AISI 304
7	Unplated lockwing	1	CW617N
8	O-Ring	2	FPM
9	Washer (from 3/4" to 2")	1	PTFE glass filled 25%

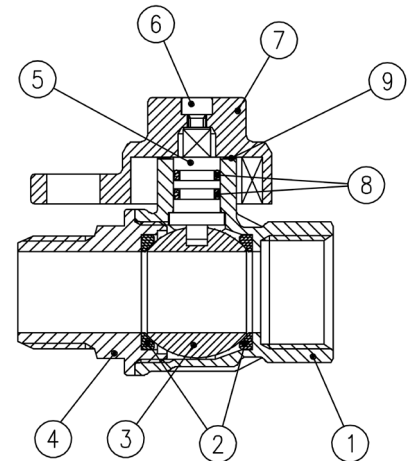

1 1/4"-2" hollow ball

For sales within EU: CE marking needed, please contact us

Code	S80E42	S80F42	S80G42	S80H42	S80I42
D (inch)	3/4"	1"	1 1/4"	1 1/2"	2"
DN (inch)	0.748	0.945	1.181	1.496	1.890
I (inch)	0.669	0.827	0.906	0.906	1.043
I1 (inch)	0.709	0.866	0.945	0.945	1.083
L (inch)	2.992	3.642	4.173	4.449	5.236
G (inch)	1.260	1.594	1.831	2.008	2.382
A (inch)	1.142	1.142	1.209	1.209	1.209
H (inch)	1.831	1.988	2.559	2.795	3.071
M (inch)	0.492	0.492	0.472	0.472	0.472
N (inch)	0.449	0.449	0.563	0.563	0.563
CH (inch)	1.220	1.575	1.929	2.126	2.697
Cv (GPM)	48.5	80.9	92.4	144.4	206.8

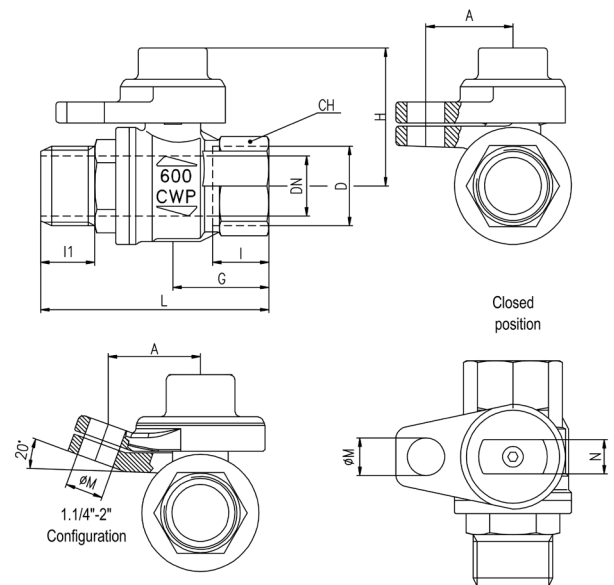

DN shows the nominal flow diameter. Actual flow diameter complies with full port DIN 3357 part 4.

PRESSURE-TEMPERATURE CHART

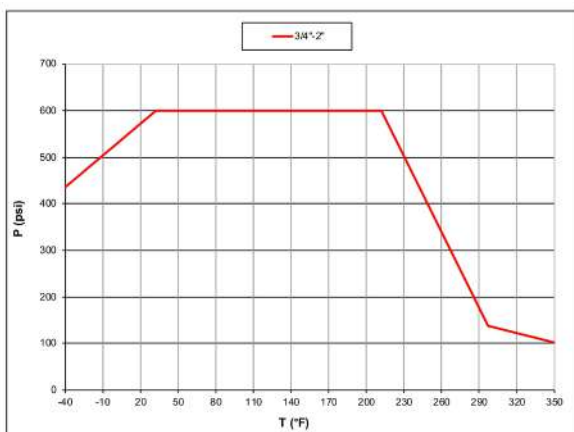

PRESSURE DROP CHART

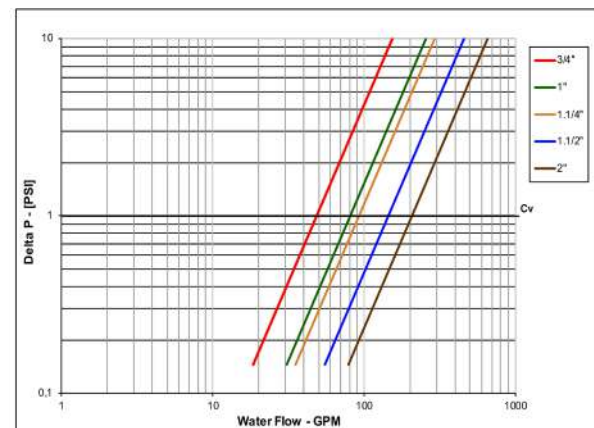



s.8043 NPT dielectric

3/4" - 1 1/4"
with tamper proof lockwing

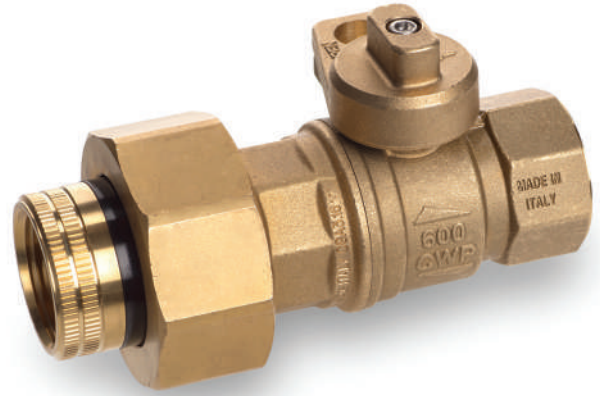

QUALITY

- 24h 100% seal test guaranteed
- No metal-to-metal moving parts
- No maintenance ever required
- Cover clearly shows ball position
- Silicone-free lubricant on all seals
- Chrome plated brass ball for longer life
- Handle stops on body to avoid stresses at stem

BODY

- Hot forged sand blasted, unplated brass body and cap sealed with Loctite® or equivalent thread sealant
- Special design to combine newest technologies in valve and traditional gascock requirements
- Finest brass according to EN 12165 and EN 12164 specifications

STEM

- Blowout-proof unplated brass stem
- Maintenance-free, double FPM O-rings at the stem for maximum safety

SEALING

- Pure PTFE self-lubricating seats with flexible-lip design

THREADS

- NPT taper ANSI B.1.20.1 female by dielectric union female threads

FLOW

- Full port to DIN 3357 for maximum flow

HANDLE

- Hot forged brass tamper proof lockwing

OPTIONS

- Painted gray
- Dielectric union end long or short pattern

WORKING PRESSURE & TEMPERATURE

- 600 PSI (40 bar) non-shock cold working pressure
- 250 PSI (17 bar) non-shock working pressure for LP-Gas
- -40°F to +350°F (-40°C / +170°C)
- **WARNING:** freezing of the fluid in the installation may severely damage the valve

UPON REQUEST

- See s.80
- * For sales within EU: CE marking needed, please contact us

APPROVED BY OR IN COMPLIANCE WITH

- Underwriters Laboratories (United States, Canada):
 - Guide YSDT: LP-Gas shut-off valve
 - Guide YRBX: Flammable liquid shut-off valve
 - Guide YRPV: Gas shut-off valve for use with natural and manufactured gases
- EAC – Declaration of conformity (Russia, Kazakhstan, Belarus)
- RoHS Compliant (EU)
- Canadian standards Association (United States, Canada)

NOTE: approvals apply to specific configurations/sizes only.

s.8043 NPT XCES8043 - 6012

Each user should perform his own tests to find out the suitability for his particular application. BONOMI INDUSTRIES makes no warranty, express or implied, as to the shape, fit or function of a product for any application. Contact us or consult with your supplier for additional information on the suitability of the BONOMI INDUSTRIES products with your specific field of use.



GAS

For sales within EU:
CE marking needed,
please contact us

Part description	Q.ty	Material
1 Unplated body	1	CW617N
2 Seat	2	PTFE
3 Chrome plated ball	1	CW617N
4 Unplated spacer	1	CW617N
5 Tail piece O-Ring	1	FPM
6 Unplated nut	1	CW617N
7 Dielectric tail piece	1	CW617N
8 Insulation	1	Polyamide
9 Unplated stem O-ring design	1	CW617N
10 Stainless steel screw	1	1.4301 / AISI 304
11 Unplated lockwing	1	CW617N
12 Washer	1	PTFE glass filed 25%
13 Stem O-ring	2	FPM

Code	S80E43	S80F43	S80G43
D (inch)	3/4"	1"	1 1/4"
DN (inch)	0.748	0.945	1.181
I (inch)	0.669	0.827	0.906
L (inch)	4.508	5.157	5.236
G (inch)	1.260	1.594	1.831
A (inch)	1.141	1.141	1.209
H (inch)	1.831	1.988	2.559
M (inch)	0.492	0.492	0.472
N (inch)	0.449	0.449	0.563
CH (inch)	1.220	1.575	1.929
CH1 (inch)	1.220	1.575	1.929
CH2 (inch)	1.811	2.402	2.441
Cv (GPM)	48.5	80.9	92.4

1 1/4" hollow ball

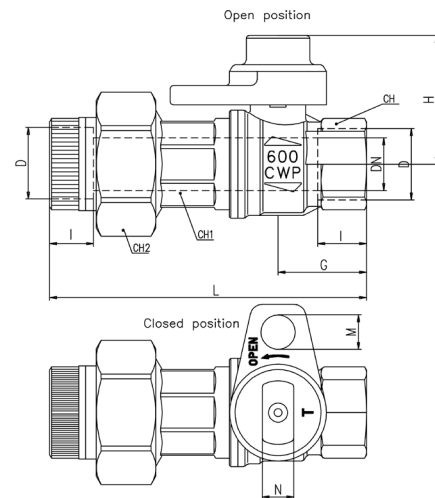
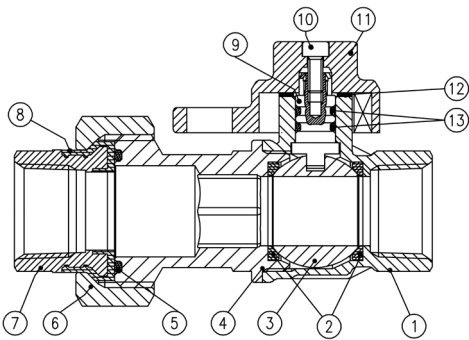

DN shows the nominal flow diameter.
Actual flow diameter complies with full port DIN 3357 part 4.

PRESSURE-TEMPERATURE CHART

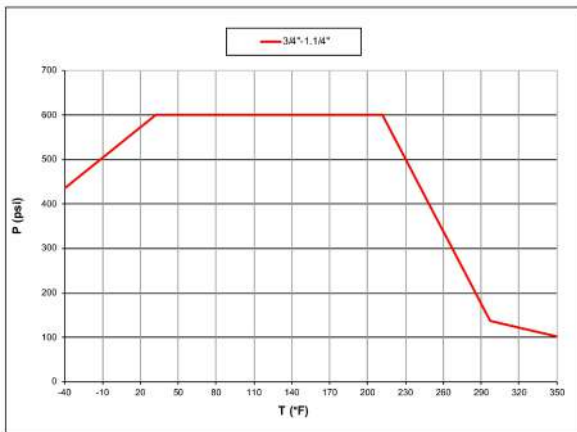
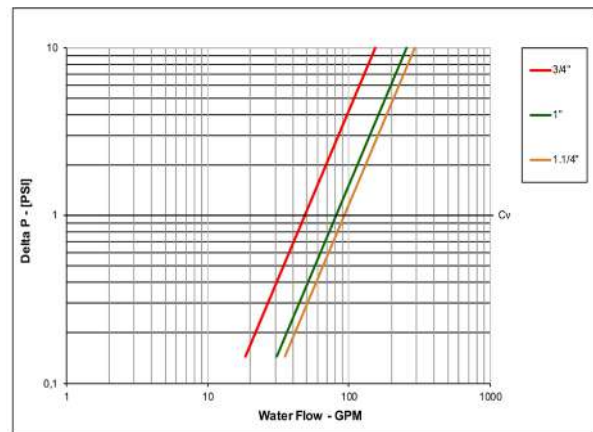

Chart applies to valve

PRESSURE DROP CHART





s.82 NPT

Female/Female
1/2" - 2" side drain



QUALITY

- 24h 100% seal test guaranteed
- Dual sealing system allows valve to be operated in either direction making installation easier
- No metal-to-metal moving parts
- No maintenance ever required
- Handle clearly shows ball position
- Silicone-free lubricant on all seals
- Handle stops on body to avoid stress at stem
- Chrome plated brass ball for longer life

BODY

- Hot forged sand blasted, unplated brass body and cap sealed with Loctite® or equivalent thread sealant
- Side drain allows easy and safe downstream line venting
- Finest brass according to EN 12165 and EN 12164 specifications

STEM

- Blowout-proof nickel plated brass stem
- Maintenance-free, double FPM O-rings at the stem for maximum safety

SEALING

- Pure PTFE self-lubricating seats with flexible-lip design

THREADS

- NPT taper ANSI B.1.20.1 female by female threads
- 1/4" NPT side tap

FLOW

- Full port to DIN 3357 for maximum flow

HANDLE

- Geomet® carbon steel handle with thick PVC dip coating. Handle coating offers both thermal and electrical protection
- Handle removable with valve in service
- **WARNING:** do not exceed reasonable temperature and/or electrical load

WORKING PRESSURE & TEMPERATURE

- 600 PSI (40 bar) non-shock cold working pressure
- 250 PSI (17 bar) non-shock working pressure for LP-Gas
- -40°F/+350°F (-40°C / +170°C)
- **WARNING:** freezing of the fluid in the installation may severely damage the valve

UPON REQUEST

- Stainless steel ball and/or stem (1.4401 / AISI 316)
- Glass filled PTFE seals
- Custom design
- Dual side drain port

PED DIRECTIVE

- Assessment according to Pressure Equipment Directive 2014/68/UE module B+D by ICIM (0425)

APPROVED BY OR IN COMPLIANCE WITH

- Canadian standards Association (United States, Canada)
- EAC – Declaration of conformity (Russia, Kazakhstan, Belarus)
- RoHS Compliant (EU)
- Underwriters Laboratories (United States, Canada):
 - Guide YSDT: LP-Gas shut-off valve
 - Guide YRBX: Flammable liquid shut-off valve
 - Guide YRPV: Gas shut-off valve for use with natural and manufactured gases
 - Guide MHKZ: No. 6 oil at 250°F

NOTE: approvals apply to specific configurations/sizes only.

OPTIONS

- Stem extension
- Oval lockable handle **1**
- Patented locking device **2**
- Stainless steel handle (1.4016 / AISI 430) **3**
- Stubby handle **4**
- T-handle **5**
- **RuB** memory stop designed to be installed with our stubby handle



s.82 NPT XCES82 - 6012

Each user should perform his own tests to find out the suitability for his particular application. BONOMI INDUSTRIES makes no warranty, express or implied, as to the shape, fit or function of a product for any application. Contact us or consult with your supplier for additional information on the suitability of the BONOMI INDUSTRIES products with your specific field of use.



Part description		Q.ty	Material
1	Unplated body	1	CW617N
2	Seat	2	PTFE
3	Chrome plated ball	1	CW617N
4	Unplated NPT end-cap	1	CW617N
5	Nickel plated stem O-ring design	1	CW617N
6	Geomet® nut	1	C4C (EN10263-2)
7	O-Ring	2	FPM
8	Yellow PVC coated Geomet® steel handle	1	DD11 (EN10111)
9	Unplated plug	1	CW617N

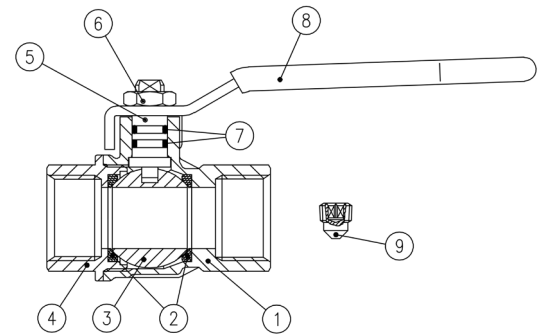

1 1/4"-2" hollow ball

For sales within EU: CE marking needed, use following codes:
S82G41CE S82H41CE S82I41CE

Code	S82D41	S82E41	S82F41	S82G41	S82H41	S82I41
D (inch)	1/2"	3/4"	1"	1 1/4"	1 1/2"	2"
DN (inch)	0.591	0.748	0.945	1.181	1.496	1.890
I (inch)	0.610	0.669	0.827	0.906	0.906	1.043
L (inch)	2.559	2.736	3.406	3.878	4.232	4.961
G (inch)	1.398	1.476	1.811	2.047	2.224	2.579
A (inch)	3.937	4.724	4.724	6.220	6.220	6.220
H (inch)	1.679	1.956	2.114	2.858	3.094	3.370
M (inch)	0.964	1.063	1.200	1.338	1.516	1.752
CH (inch)	0.984	1.220	1.575	1.929	2.126	2.697
Cv (GPM)	32.3	48.5	80.9	92.4	144.4	206.8

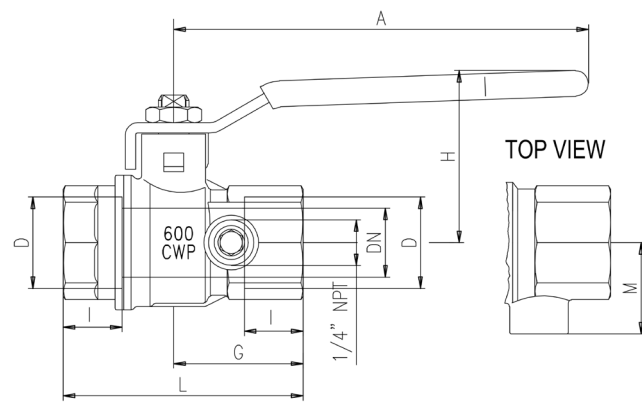

DN shows the nominal flow diameter. Actual flow diameter complies with full port DIN 3357 part 4.

For sales within EU: ball valves are marked CE on handle from 1 1/4" to 2" as follow:

CE 0425 cat IIIB+D PS: 5 GAS TS1: -20°C TS2: +60°C

PRESSURE-TEMPERATURE CHART

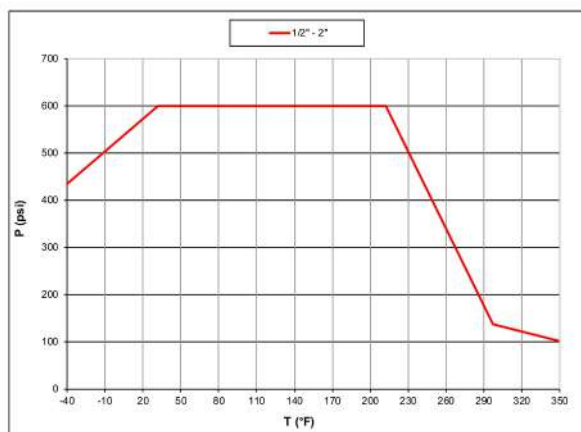

PRESSURE DROP CHART

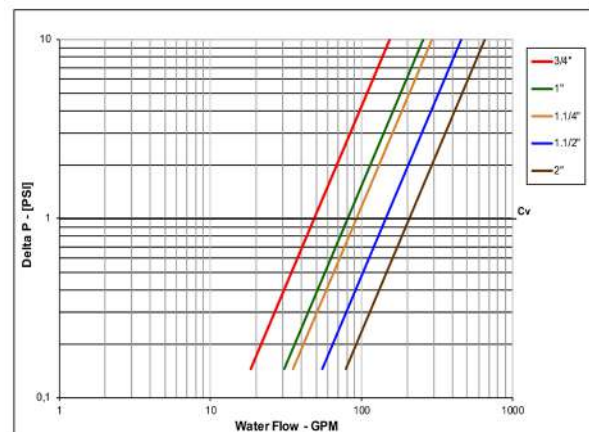



k.84

Female/Female
1/4" - 2"
EN 10226-1, DIN 16722 M3

HIGH TEMPERATURE RESISTANCE

Now approved for HTB use (Hochtemperaturbeständigkeit)

Class B 0,1 (0,1 bar @650°C for at least 30 minutes).



H2 READY: product approved in EU acc.to EN331 (sizes 1/4" to 2") for the 1st, 2nd and 3rd gas families, therefore compatible with hydrogen use up to 50% in the gas mixture, as established in the 1st gas family of the EN437 (ref. G110)



QUALITY

- 24h 100% seal test guaranteed
- Dual sealing system allows valve to be operated in either direction making installation easier
- No metal-to-metal moving parts
- No maintenance ever required
- Handle clearly shows ball position
- Silicone-free lubricant on all seals
- Handle stops on body to avoid stresses at stem
- Chrome plated brass ball for longer life with rinse hole

BODY

- Valve length according to DIN 16722 M3 for sizes from 3/8" to 2" (DN10 to DN50). Size 1/4" (DN 8) complies to DIN 3202 M3.
- Finest brass according to EN 12165 and EN 12164 specifications
- Hot forged sand blasted external nickel plated brass body and cap sealed with Loctite® or equivalent threads sealant

STEM

- Blowout-proof nickel plated brass stem
- Maintenance-free, double FPM O-rings at the stem for maximum safety

SEALING

- Pure PTFE self-lubricating seats with flexible-lip design

THREADS

- EN 10226-1, ISO 7/1, ISO 228 parallel female by female threads

PED DIRECTIVE

- Assessment according to Pressure Equipment Directive 2014/68/UE module B+D by ICIM (0425)

FLOW

- Full port to DIN 3357 for maximum flow

HANDLE

- Geomet® carbon steel handle with thick PVC dip coating. Handle coating offers both thermal and electrical protection
- **WARNING:** do not exceed reasonable temperature and/or electrical load
- Handle removable with valve in service

WORKING PRESSURE & TEMPERATURE

- 40 bar (600 PSI) non-shock cold working pressure
- -40°C to +170°C (-40°F to +350°F)
- For use with dangerous fluids temperature rating is
- -20°C to +60°C (-4°F to +140°F) and pressure rating is 5 bar (72 PSI) /

HTB Class B 0,1

- **WARNING:** freezing of the fluid in the installation may severely damage the valve

UPON REQUEST

- Stainless steel ball (1.4401 / AISI 316)
- Glass filled PTFE seals
- Custom design

APPROVED BY OR IN COMPLIANCE WITH

- BSI Group (United Kingdom)
- SVGW (Switzerland)
- RoHS Compliant (EU)
- DIN-DVGW (Germany) – MOP 5 B 0,1
- EAC – Declaration of conformity (Russia, Kazakhstan, Belarus)

NOTE: approvals apply to specific configurations/sizes only.

OPTIONS

- Stem extension
- Oval lockable handle ①
- Patented locking device ②
- Stainless steel handle (1.4016 / AISI 430) ③
- Stubby handle ④
- T-handle ⑤
- **RuB** memory stop designed to be installed with our stubby handle



K.84 XCEK84 - 5813

Each user should perform his own tests to find out the suitability for his particular application. BONOMI INDUSTRIES makes no warranty, express or implied, as to the shape, fit or function of a product for any application. Contact us or consult with your supplier for additional information on the suitability of the BONOMI INDUSTRIES products with your specific field of use.



Part description	Q.ty	Material
1 Nickel plated body (external treatment)	1	CW617N
2 Ball seat	2	PTFE
3 Chrome plated ball with rinse hole (read rinse hole on sizes from 3/4" up to 2")	1	CW617N
4 Nickel plated end-cap (external treatment)	1	CW617N
5 Nickel plated stem O-ring design	1	CW617N
6 Geomet® nut	1	C4C (EN10263-2)
7 O-Ring	2	FPM
8 Yellow PVC coated Geomet® steel handle	1	DD11 (EN10111)

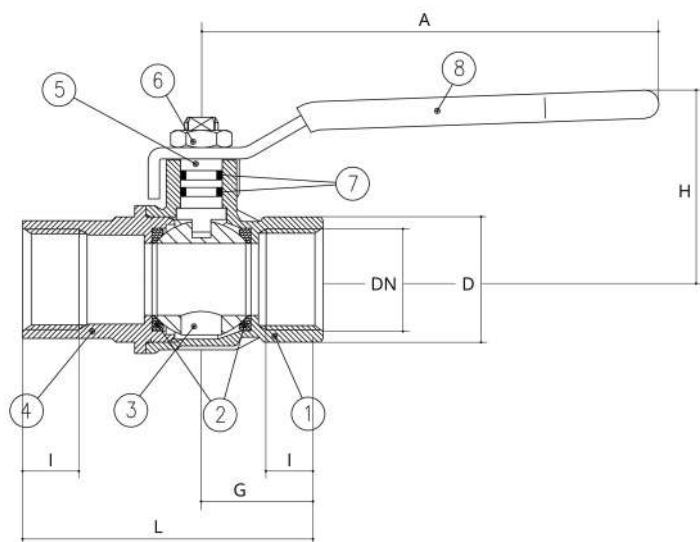

1 1/4"-2" hollow ball

Compliant to CE 2014/68/UE product Equipment category III Module B+D

Code	S84B05	S84C05	S84D05	S84E05	S84F05	S84G05	S84H05	S84I05
D (inch)	1/4"	3/8"	1/2"	3/4"	1"	1 1/4"	1 1/2"	2"
DN (mm)	8	10	15	20	25	32	40	50
I (mm)	12	12	15.5	17	21	23	23	26.5
L (mm)	50	60	75	80	90	110	120	140
G (mm)	22.5	22.5	29.5	32	40.5	46.5	51	60.5
A (mm)	82	82	100	120	120	158	158	158
H (mm)	38	38	43	50	54	73	79	86
CH (mm)	17	20	25	31	40	49	54	68.5
Kv (m3/h)	3.9	8.2	28	36	62	79	124	178

DN shows the nominal flow diameter. Actual flow diameter complies with full port DIN 3357 part 4.

Ball valves are marked CE on handle from 1 1/4" to 2" as follow:

CE 0425 cat IIIB+D PS: 5 GAS TS1:-20°C TS2:+60°C

PRESSURE-TEMPERATURE CHART

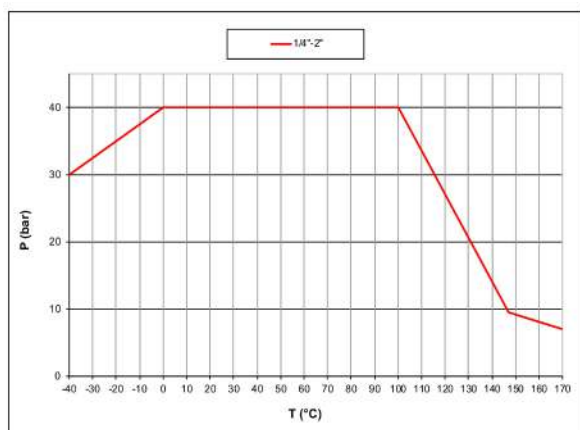

PRESSURE DROP CHART

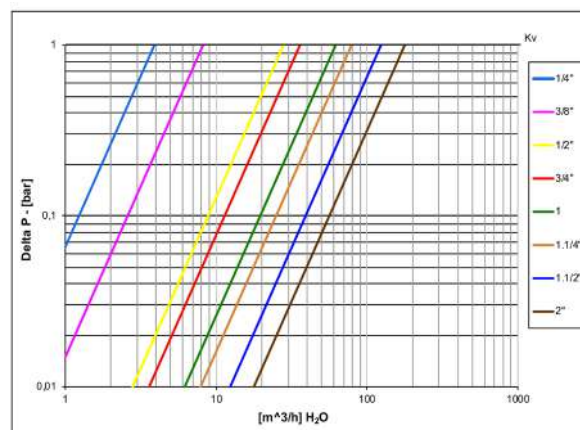



s.84 IR6

Female/Female
1/2" - 1"
EN 10226-1

HIGH TEMPERATURE RESISTANCE

Now approved for HTB use (Hochtemperaturbeständigkeit)
Class B 0,1 (0,1 bar @650°C for at least 30 minutes).



QUALITY

- 24h 100% seal test guaranteed
- Dual sealing system allows valve to be operated in either direction making installation easier
- No metal-to-metal moving parts
- No maintenance ever required
- Handle clearly shows ball position
- Silicone-free lubricant on all seals
- Handle stops on body to avoid stresses at stem
- Chrome plated brass ball for longer life with rinse hole

BODY

- Hot forged sand blasted external nickel plated brass body and cap sealed with Loctite® or equivalent thread sealant
- Finest brass according to EN 12165 and EN 12164 specifications

STEM

- Blowout-proof nickel plated brass stem
- Maintenance- free, double FPM O-rings at the stem for maximum safety

SEALING

- Pure PTFE self-lubricating seats with flexible-lip design

THREADS

- EN 10226-1, ISO 228 parallel female by female threads

UPON REQUEST

- Stainless steel ball (1.4401 / AISI 316)
- Glass filled PTFE seals
- Custom design

OPTIONS

- Stem extension
- Geomet® carbon steel handle with PVC dip coating
- Stainless steel handle (1.4016 / AISI 430)
- Taper male by union end
- Oval lockable handle
- Patented locking device
- Stubby handle
- RuB memory stop designed to be installed with our stubby handle

PED DIRECTIVE

- The product described in this document meets the requirements of PED Directive 2014/68/UE and according to art.4 par.3, it does not require CE marking

FLOW

- Full port to DIN 3357 for maximum flow

HANDLE

- Aluminum T-handle, painted yellow.
- **WARNING:** do not exceed reasonable temperature and/or electrical load
- T-handle removable with valve in service

WORKING PRESSURE & TEMPERATURE

- 40 bar (600 PSI) non-shock cold working pressure
- -40°C to +170°C (-40°F to +350°F)
- For use with dangerous fluids temperature rating is -20°C +60°C and pressure rating is 5 bar / HTB Class B 0,1
- **WARNING:** freezing of the fluid in the installation may severely damage the valve

APPROVED BY OR IN COMPLIANCE WITH

- RoHS Compliant (EU)
- EAC – Declaration of conformity (Russia, Kazakhstan, Belarus)
- DIN-DVGW (Germany) – MOP 5 B 0,1*
- ARGB-KVBG (Belgium) – MOP 5 bar for outside building gas installation*

NOTE: approvals apply to specific configurations/sizes only.

* = valve only is approved to EN331 / EN1775.



s.84 IR6 XCES84IR6 - 5813

Each user should perform his own tests to find out the suitability for his particular application. BONOMI INDUSTRIES makes no warranty, express or implied, as to the shape, fit or function of a product for any application. Contact us or consult with your supplier for additional information on the suitability of the BONOMI INDUSTRIES products with your specific field of use.



GAS

	Part description	Q.ty	Material
1	Nickel plated body (external nickel plated, unplated inside)	1	CW617N
2	Seat	2	PTFE
3	Chrome plated ball	1	CW617N
4	Nickel plated end-cap (external nickel plated, unplated inside)	1	CW617N
5	Nickel plated stem O-ring design	1	CW617N
6	Geomet® nut	1	C4C (EN10263-2)
7	O-Ring	2	FPM
8	Yellow T-handle	1	EN AC-46100 (EN1676)
9	Nickel plated union nut	1	CW617N
10	O-Ring	1	FPM
11	Nickel plated union end	1	CW617N

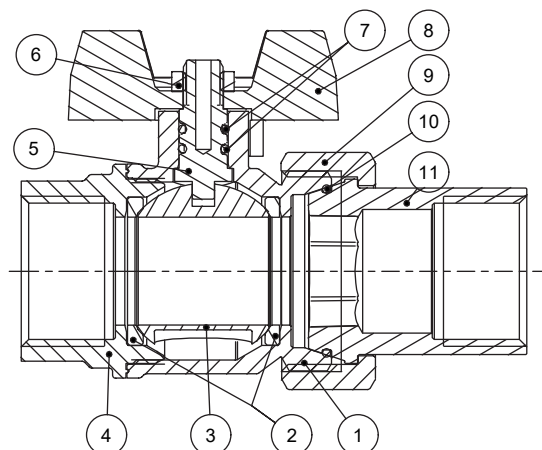

Code	S84D1R6	S84E1R6	S84F1R6
D (inch)	1/2"	3/4"	1"
DN (mm)	15	20	25
I (mm)	15.5	17	21
L (mm)	84.2	95.5	112
G (mm)	55	63.5	71.7
H (mm)	43	49.5	53.5
Kv (m3/h)	28	42	62

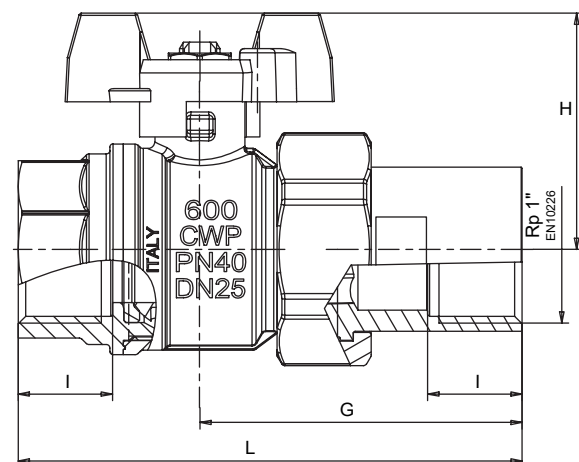

DN shows the nominal flow diameter. Actual flow diameter complies with full port DIN 3357 part 4.

PRESSURE-TEMPERATURE CHART

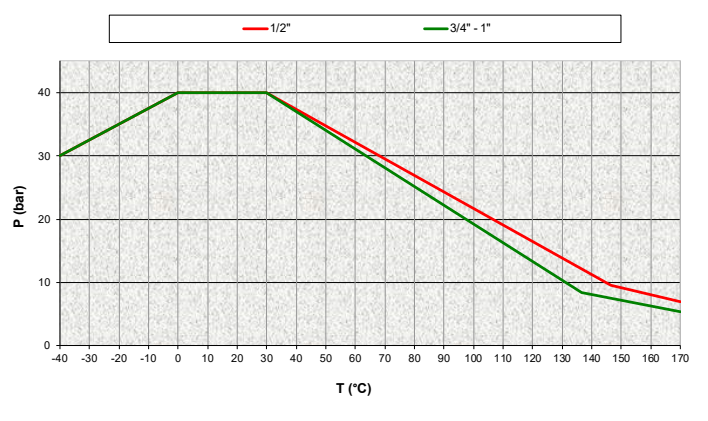

PRESSURE DROP CHART

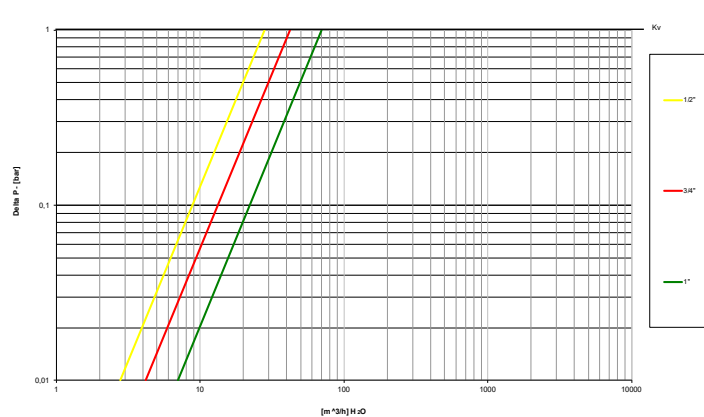



s.84 EN331

Female/Female
1/4" - 4"
EN 10226-1

HIGH TEMPERATURE RESISTANCE

Now approved for HTB use (Hochtemperaturbeständigkeit)

Class B 0,1 (0,1 bar @650°C for at least 30 minutes).



H2 READY: product approved in EU acc.to EN331 (sizes 1/4" to 2") for the 1st, 2nd and 3rd gas families, therefore compatible with hydrogen use up to 50% in the gas mixture, as established in the 1st gas family of the EN437 (ref. G110)



QUALITY

- 24h 100% seal test guaranteed
- Dual sealing system allows valve to be operated in either direction making installation easier
- No metal-to-metal moving parts
- No maintenance ever required
- Handle clearly shows ball position
- Silicone-free lubricant on all seals
- Handle stops on body to avoid stresses at stem
- Chrome plated brass ball for longer life with rinse hole

BODY

- Hot forged sand blasted external nickel plated brass body and cap sealed with Loctite® or equivalent thread sealant
- Finest brass according to EN 12165 and EN 12164 specifications

STEM

- Blowout-proof nickel plated brass stem
- Maintenance-free, double FPM O-rings at the stem for maximum safety

SEALING

- Pure PTFE self-lubricating seats with flexible-lip design

THREADS

- EN 10226-1, ISO 228 parallel female by female threads

UPON REQUEST

- Stainless steel ball (1.4401 / AISI 316)
- Glass filled PTFE seals
- Custom design

FLOW

- Full port to DIN 3357 for maximum flow

OPTIONS UP TO 2" SIZE

- Oval lockable handle up to 2", round over 2" **1**
- Patented locking device for valves up to 4" **2**
- Stainless steel handle (1.4016 / AISI 430) **3**
- Stubby handle **4**
- T-handle **5**
- Stem extension
- **RuB** memory stop designed to be installed with our stubby handle

PED DIRECTIVE

- Assessment according to Pressure Equipment Directive 2014/68/UE module B+D by ICIM (0425)

HANDLE

- Geomet® carbon steel handle with thick PVC dip coating. Handle coating offers both thermal and electrical protection
- **WARNING:** do not exceed reasonable temperature and/or electrical load
- Handle removable with valve in service

WORKING PRESSURE & TEMPERATURE

- 40 bar (600 PSI) up to 2", 30 bar (450 PSI) over 2" non-shock cold working pressure
- -40°C to +170°C (-40°F to +350°F)
- For use with dangerous fluids temperature rating is -20°C +60°C and pressure rating is 5 bar / **HTB** Class B 0,1
- AS4617 Limitation for GAS: 2100 Kpa up to 2" and 1500 Kpa from 2 1/2" to 4" rated working pressure and 0°C / +60°C temperature
- **WARNING:** freezing of the fluid in the installation may severely damage the valve

APPROVED BY OR IN COMPLIANCE WITH

- The Australian Gas Association (Australia)
- SVGW (Switzerland)
- Factory Mutual (United States)
- BSI Group (United Kingdom)
- RoHS Compliant (EU)
- DIN-DVGW (Germany) – MOP 5 B 0,1
- EAC – Declaration of conformity (Russia, Kazakhstan, Belarus)
- ARGB-KVBG (Belgium) – MOP 5 bar for outside building gas installation, MOP 100 mbar for inside the buildings

NOTE: approvals apply to specific configurations/sizes only.



s.84EN331 XCES84E - 5813

Each user should perform his own tests to find out the suitability for his particular application. BONOMI INDUSTRIES makes no warranty, express or implied, as to the shape, fit or function of a product for any application. Contact us or consult with your supplier for additional information on the suitability of the BONOMI INDUSTRIES products with your specific field of use.



GAS

Part description	Q.ty	Material
1 Nickel plated body (external nickel plated, unplated inside up to 2")	1	CW617N
2 Seat	2	PTFE
3 Chrome plated ball with rinse hole (read rinse hole on sizes from 3/4" up to 2")	1	CW617N
4 Nickel plated end-cap (external nickel plated, unplated inside up to 2")	1	CW617N
5 Nickel plated stem O-ring design	1	CW617N
6 Geomet® nut	1	C4C (EN10263-2)
7 O-Ring	2	FPM
8 Yellow PVC coated Geomet® steel handle	1	DD11 (EN10111)

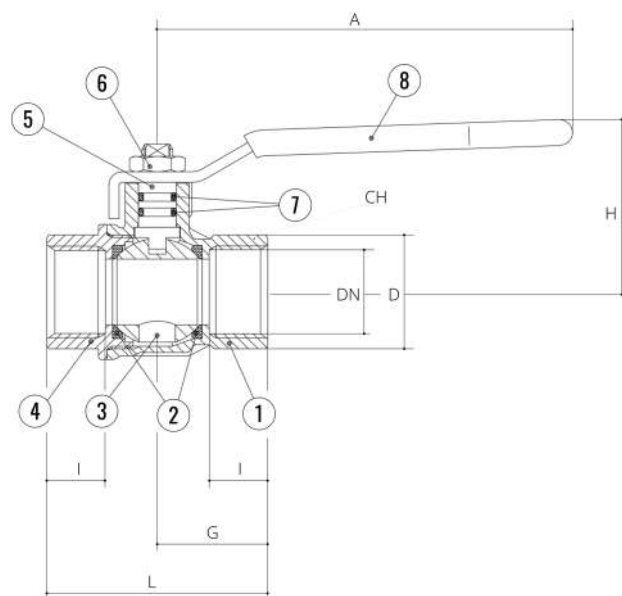

1 1/4" - 2" hollow ball

Compliant to CE 2014/68/UE product Equipment category III Module B+D

Code	S84B00	S84C00	S84D00	S84E00	S84F00	S84G00	S84H00	S84I00	S84L00	S84M00	S84N00
D (inch)	1/4"	3/8"	1/2"	3/4"	1"	1 1/4"	1 1/2"	2"	2 1/2"	3"	4"
DN (mm)	8	10	15	20	25	32	40	50	65	80	100
I (mm)	12	12	15.5	17	21	23	23	26.5	32	35	41.5
L (mm)	45	45	59	64	81	93	102	121	156	177	216
G (mm)	22.5	22.5	29.5	32	40.5	46.5	51	60.5	78	88.5	108
A (mm)	82	82	100	120	120	158	158	158	255	255	255
H (mm)	38	38	43	50	54	73	79	86	132	140	154
CH (mm)	17	20	25	31	40	49	54	68.5	85	99	125
Kv (m3/h)	3.9	8.2	28	36	62	79	124	178	516	776	1130

DN shows the nominal flow diameter. Actual flow diameter complies with full port DIN 3357 part 4. Stem configuration of valves over 2" is slightly different. Ball valves are marked CE on handle from 1 1/4" to 2", on body over 2" as follow:

CE 0425 cat IIIB+D PS: 5 GAS TS1: -20°C TS2: +60°C

PRESSURE-TEMPERATURE CHART

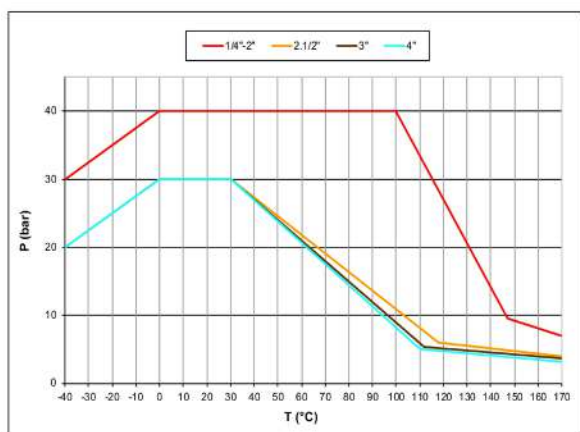

AS4617 limitations for GAS: 2100 Kpa up to 2" and 1500 Kpa from 2 1/2" to 4" rated working pressure and 0°C +60°C temperature

PRESSURE DROP CHART

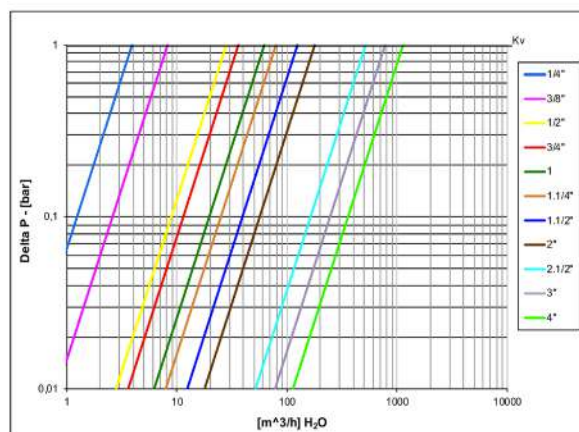



s.84 EN331 M/F

Male/Female
1/4" - 4"
EN 10226-1

HIGH TEMPERATURE RESISTANCE

Now approved for HTB use (Hochtemperaturbeständigkeit)
Class B 0,1 (0,1 bar @650°C for at least 30 minutes).



H2 READY: product approved in EU acc.to EN331 (sizes 1/4" to 2") for the 1st, 2nd and 3rd gas families, therefore compatible with hydrogen use up to 50% in the gas mixture, as established in the 1st gas family of the EN437 (ref. G110)



QUALITY

- 24h 100% seal test guaranteed
- Dual sealing system allows valve to be operated in either direction making installation easier
- No metal-to-metal moving parts
- No maintenance ever required
- Handle clearly shows ball position
- Silicone-free lubricant on all seals
- Handle stops on body to avoid stresses at stem
- Chrome plated brass ball for longer life with rinse hole

BODY

- Hot forged sand blasted external nickel plated brass body and cap sealed with Loctite® or equivalent thread sealant
- Finest brass according to EN 12165 and EN 12164 specifications

STEM

- Blowout-proof nickel plated brass stem
- Maintenance-free, double FPM O-rings at the stem for maximum safety

SEALING

- Pure PTFE self-lubricating seats with flexible-lip design

THREADS

- EN 10226-1, ISO 228 parallel female thread by EN10226-1, ISO7/1 taper male thread

PED DIRECTIVE

- Assessment according to Pressure Equipment Directive 2014/68/UE module B+D by ICIM (0425)

FLOW

- Full port to DIN 3357 for maximum flow

HANDLE

- Geomet® carbon steel handle with thick PVC dip coating. Handle coating offers both thermal and electrical protection
- **WARNING:** do not exceed reasonable temperature and/or electrical load
- Handle removable with valve in service

WORKING PRESSURE & TEMPERATURE

- 40 bar (600 PSI) up to 2", 30 bar (450 PSI) over 2" non-shock cold working pressure
- -40°C to +170°C (-40°F to +350°F)
- For use with dangerous fluids temperature rating is -20°C +60°C and pressure rating is 5 bar / HTB Class B 0,1
- AS4617 Limitation for GAS: 2100 Kpa up to 2" and 1500 Kpa from 2 1/2" to 4" rated working pressure and 0°C / +60°C temperature
- **WARNING:** freezing of the fluid in the installation may severely damage the valve

UPON REQUEST

- Stainless steel ball (1.4401 / AISI 316)
- Glass filled PTFE seals
- Custom design

APPROVED BY OR IN COMPLIANCE WITH

- The Australian Gas Association (Australia)
- SVGW (Switzerland)
- Factory Mutual (United States)
- BSI Group (United Kingdom)
- RoHS Compliant (EU)
- DIN-DVGW (Germany) – MOP 5 B 0,1
- EAC – Declaration of conformity (Russia, Kazakhstan, Belarus)
- ARGB-KVBG (Belgium) – MOP 5 bar for outside building gas installation

NOTE: approvals apply to specific configurations/sizes only.

OPTIONS UP TO 2" SIZE

- Oval lockable handle up to 2", round over 2" **1**
- Patented locking device for valves up to 4" **2**
- Stainless steel handle (1.4016 / AISI 430) **3**
- Stubby handle **4**
- T-handle **5**
- Stem extension
- **RuB** memory stop designed to be installed with our stubby handle



s.84 EN331 MF XGES84EM - 5813

Each user should perform his own tests to find out the suitability for his particular application. BONOMI INDUSTRIES makes no warranty, express or implied, as to the shape, fit or function of a product for any application. Contact us or consult with your supplier for additional information on the suitability of the BONOMI INDUSTRIES products with your specific field of use.



Part description	Q.ty	Material
1 Nickel plated body (external nickel plated, unplated inside up to 2")	1	CW617N
2 Seat	2	PTFE
3 Chrome plated ball with rinse hole (read rinse hole on sizes from 3/4" up to 2")	1	CW617N
4 Nickel plated end-cap (external nickel plated, unplated inside up to 2")	1	CW617N
5 Nickel plated stem O-ring design	1	CW617N
6 Geomet® nut	1	C4C (EN10263-2)
7 O-Ring	2	FPM
8 Yellow PVC coated Geomet® steel handle	1	DD11 (EN10111)

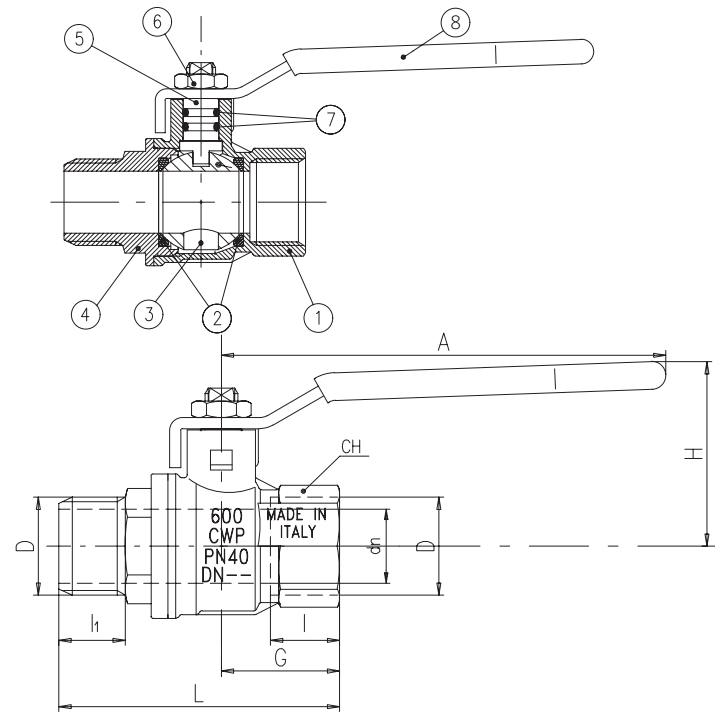

1 1/4" - 2" hollow ball

Compliant to CE 2014/68/UE product Equipment category III Module B+D

Code	S84B20	S84C20	S84D20	S84E20	S84F20	S84G20	S84H20	S84I20	S84L20	S84M20	S84N20
D (inch)	1/4"	3/8"	1/2"	3/4"	1"	1 1/4"	1 1/2"	2"	2 1/2"	3"	4"
DN (mm)	8	10	15	20	25	32	40	50	65	80	100
I (mm)	12	12	15.5	17	21	23	23	26.5	32	35	41.5
I1 (mm)	13.5	13.5	16.5	18	22	24	24	27.5	37	39.5	44
L (mm)	56.5	56.5	70	76.5	92.5	106	113	133	180.5	204.5	238
G (mm)	22.5	22.5	29.5	32	40.5	46.5	51	60.5	78	88.5	108
A (mm)	82	82	100	120	120	158	158	158	255	255	255
H (mm)	38	38	43	50	54	73	79	86	132	140	154
CH (mm)	17	20	25	31	40	49	54	68.5	85	99	125
Kv (m3/h)	3.9	8.2	28	36	62	79	124	178	516	776	1130

DN shows the nominal flow diameter. Actual flow diameter complies with full port DIN 3357 part 4. Stem configuration of valves over 2" is slightly different. Ball valves are marked CE on handle from 1 1/4" to 2", on body over 2" as follow:

CE 0425 cat IIIB+D PS: 5 GAS TS1: -20°C TS2: +60°C

PRESSURE-TEMPERATURE CHART

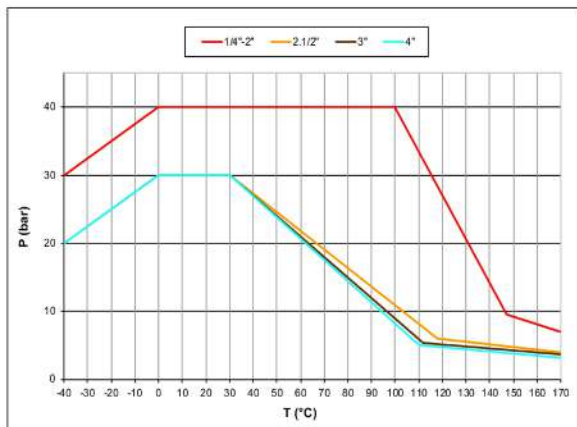

AS4617 limitations for GAS: 2100 Kpa up to 2" and 1500 Kpa from 2 1/2" to 4" rated working pressure and 0°C +60°C temperature

PRESSURE DROP CHART

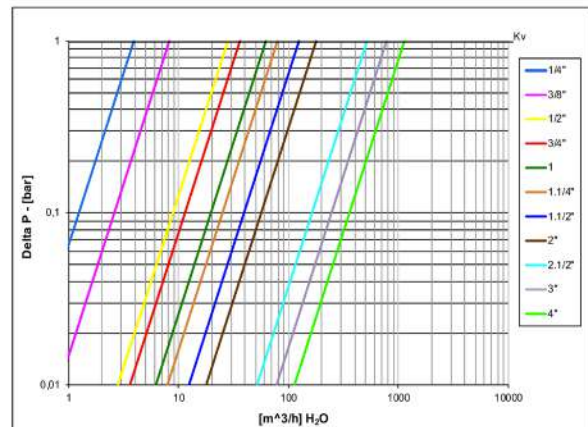



s.84 BSPT

Female/Female
1/4" - 4"



H2 READY: product approved in EU acc.to EN331 (sizes 1/4" to 2") for the 1st, 2nd and 3rd gas families, therefore compatible with hydrogen use up to 50% in the gas mixture, as established in the 1st gas family of the EN437 (ref. G110)



QUALITY

- 24h 100% seal test guaranteed
- Dual sealing system allows valve to be operated in either direction making installation easier
- No metal-to-metal moving parts
- No maintenance ever required
- Handle clearly shows ball position
- Silicone-free lubricant on all seals
- Chrome plated brass ball for longer life
- Handle stops on body to avoid stresses at stem

BODY

- Hot forged sand blasted, external nickel plated brass body and cap sealed with Loctite® or equivalent thread sealant
- Finest brass according to EN 12165 and EN 12164 specifications

STEM

- Blowout-proof nickel plated brass stem
- Maintenance-free, double FPM O-rings at the stem for maximum safety

SEALING

- Pure PTFE self-lubricating seats with flexible-lip design

THREADS

- EN10226-2, ISO 7/1, BS 21 BSPT taper female by female threads

FLOW

- Full port to DIN 3357 for maximum flow

HANDLE

- Geomet® carbon steel handle with thick PVC dip coating. Handle coating offers both thermal and electrical protection
- **WARNING:** do not exceed reasonable temperature and/or electrical load

WORKING PRESSURE & TEMPERATURE

- 40 bar (600 PSI) up to 2", 30 bar (450 PSI) over 2" non-shock cold working pressure
- -40°C to +170°C (-40°F to +350°F)
- For use with dangerous fluids temperature rating is -20°C +60°C and pressure rating is 5 bar
- AS4617 Limitation for GAS: 2100 Kpa up to 2" and 1500 Kpa from 2 1/2" to 4" rated working pressure and 0°C / +60°C temperature
- **WARNING:** freezing of the fluid in the installation may severely damage the valve

UPON REQUEST

- Stainless steel ball (1.4401 / AISI 316)
- Glass filled PTFE seals
- Custom design

PED DIRECTIVE

- Assessment according to Pressure Equipment Directive 2014/68/UE module B+D by ICIM (0425)

APPROVED BY OR IN COMPLIANCE WITH

- DIN-DVGW (Germany) – MOP 5 B 0,1
- BSI Group (United Kingdom)
- RoHS Compliant (EU)
- EAC – Declaration of conformity (Russia, Kazakhstan, Belarus)
- The Australian Gas Association (Australia)

NOTE: approvals apply to specific configurations/sizes only.

OPTIONS UP TO 2" SIZE

- Stem extension
- Oval lockable handle up to 2", round over 2" **1**
- Patented locking device for valves up to 4" **2**
- Stainless steel handle (1.4016 / AISI 430) **3**
- **RuB** memory stop designed to be installed with our stubby handle
- Stubby handle **4**
- T-handle **5**



s.84 BSPT XGES84 - 5966

Each user should perform his own tests to find out the suitability for his particular application. BONOMI INDUSTRIES makes no warranty, express or implied, as to the shape, fit or function of a product for any application. Contact us or consult with your supplier for additional information on the suitability of the BONOMI INDUSTRIES products with your specific field of use.



GAS

Part description	Q.ty	Material
1 Nickel plated body (external nickel plated, unplated inside up to 2")	1	CW617N
2 Seat	2	PTFE
3 Chrome plated ball	1	CW617N
4 Nickel plated end-cap (external nickel plated, unplated inside up to 2")	1	CW617N
5 Nickel plated stem O-ring design	1	CW617N
6 Geomet® nut	1	C4C (EN10263-2)
7 O-Ring	2	FPM
8 Yellow PVC coated Geomet® steel handle	1	DD11 (EN10111)

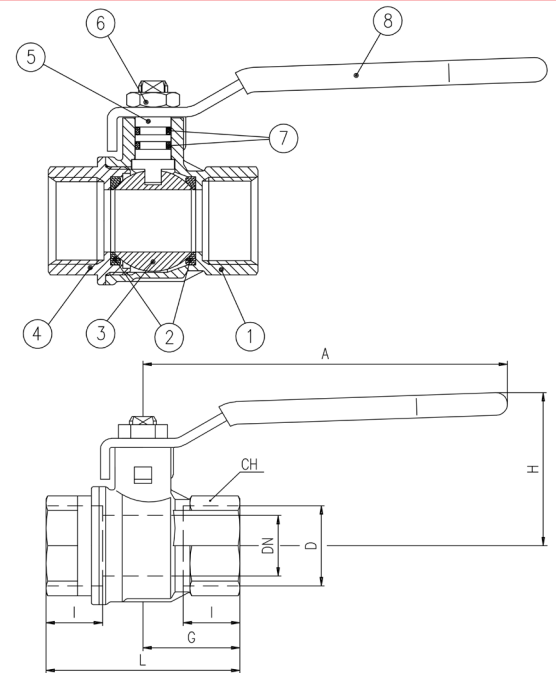

1 1/4"-2" hollow ball

Compliant to CE 2014/68/UE product Equipment category III Module B+D

Code	S84B50	S84C50	S84D50	S84E50	S84F50	S84G50	S84H50	S84I50	S84L50	S84M50	S84N50
D (inch)	1/4"	3/8"	1/2"	3/4"	1"	1 1/4"	1 1/2"	2"	2 1/2"	3"	4"
DN (mm)	8	10	15	20	25	32	40	50	65	80	100
I (mm)	12	12	15.5	17	21	23	23	26.5	32	35	41.5
L (mm)	45	45	59	64	81	93	102	121	156	177	216
G (mm)	22.5	22.5	29.5	32	40.5	46.5	51	60.5	78	88.5	108
A (mm)	82	82	100	120	120	158	158	158	255	255	255
H (mm)	38	38	43	50	54	73	79	86	132	140	154
CH (mm)	17	20	25	31	40	49	54	68.5	85	99	105

DN shows the nominal flow diameter. Actual flow diameter complies with full port DIN 3357 part 4. Stem configuration of valves over 2" is slightly different. Ball valves are marked CE on handle from 1 1/4" to 2", on body over 2" as follow:

CE 0425 cat IIIB+D PS: 5 GAS TS1:-20°C TS2: +60°C

PRESSURE-TEMPERATURE CHART

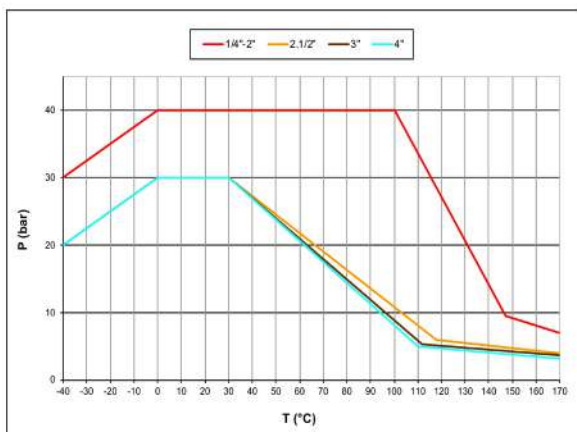

AS4617 limitations for GAS: 2100 Kpa up to 2" and 1500 Kpa from 2 1/2" to 4" rated working pressure and 0°C +60°C temperature

PRESSURE DROP CHART

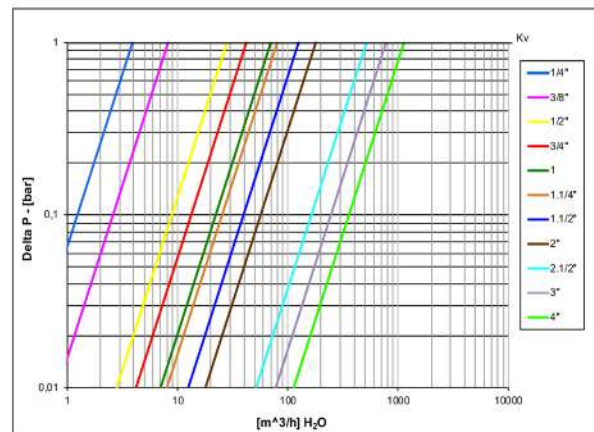



s.84 BSPT M/F

Male/Female
1/4" - 2"



H2 READY: product approved in EU acc.to EN331 (sizes 1/4" to 2") for the 1st, 2nd and 3rd gas families, therefore compatible with hydrogen use up to 50% in the gas mixture, as established in the 1st gas family of the EN437 (ref. G110)



QUALITY

- 24h 100% seal test guaranteed
- Dual sealing system allows valve to be operated in either direction making installation easier
- No metal-to-metal moving parts
- No maintenance ever required
- Handle clearly shows ball position
- Silicone-free lubricant on all seals
- Chrome plated brass ball for longer life
- Handle stops on body to avoid stresses at stem

BODY

- Hot forged sand blasted, external nickel plated brass body and cap sealed with Loctite® or equivalent thread sealant
- Finest brass according to EN 12165 and EN 12164 specifications

STEM

- Blowout-proof nickel plated brass stem
- Maintenance-free, double FPM O-rings at the stem for maximum safety

SEALING

- Pure PTFE self-lubricating seats with flexible-lip design

THREADS

- EN10226-2, ISO 7/1, BS 21 BSPT taper female by female threads

FLOW

- Full port to DIN 3357 for maximum flow

HANDLE

- Geomet® carbon steel handle with thick PVC dip coating. Handle coating offers both thermal and electrical protection
- **WARNING:** do not exceed reasonable temperature and/or electrical load

WORKING PRESSURE & TEMPERATURE

- 40 bar (600 PSI) non-shock cold working pressure
- -40°C to +170°C (-40°F to +350°F)
- For use with dangerous fluids temperature rating is -20°C +60°C and pressure rating is 5 bar
- AS4617 Limitation for GAS: 2100 Kpa up to 2" rated working pressure and 0°C / +60°C temperature
- **WARNING:** freezing of the fluid in the installation may severely damage the valve

UPON REQUEST

- Stainless steel ball (1.4401 / AISI 316)
- Glass filled PTFE seals
- Custom design

PED DIRECTIVE

- Assessment according to Pressure Equipment Directive 2014/68/UE module B+D by ICIM (0425)

APPROVED BY OR IN COMPLIANCE WITH

- The Australian Gas Association (Australia)
- BSI Group (United Kingdom)
- RoHS Compliant (EU)
- EAC – Declaration of conformity (Russia, Kazakhstan, Belarus)
- DIN-DVGW (Germany) – MOP 5 B 0,1

NOTE: approvals apply to specific configurations/sizes only.

OPTIONS UP TO 2" SIZE

- Stem extension
- Oval lockable handle **1**
- Patented locking device for valves up to 4" **2**
- Stainless steel handle (1.4016 / AISI 430) **3**
- **RuB** memory stop designed to be installed with our stubby handle
- Stubby handle **4**
- T-handle (for sizes 1/4" through 1 1/4") **5**



s.84 BSPT XGES84M - 5966

Each user should perform his own tests to find out the suitability for his particular application. BONOMI INDUSTRIES makes no warranty, express or implied, as to the shape, fit or function of a product for any application. Contact us or consult with your supplier for additional information on the suitability of the BONOMI INDUSTRIES products with your specific field of use.



Part description	Q.ty	Material
1 Nickel plated body (external nickel plated, unplated inside)	1	CW617N
2 Seat	2	PTFE
3 Chrome plated ball	1	CW617N
4 Nickel plated end-cap (external nickel plated, unplated inside)	1	CW617N
5 Nickel plated stem O-ring design	1	CW617N
6 Geomet® nut	1	C4C (EN10263-2)
7 O-Ring	2	FPM
8 Yellow PVC coated Geomet® steel handle	1	DD11 (EN10111)

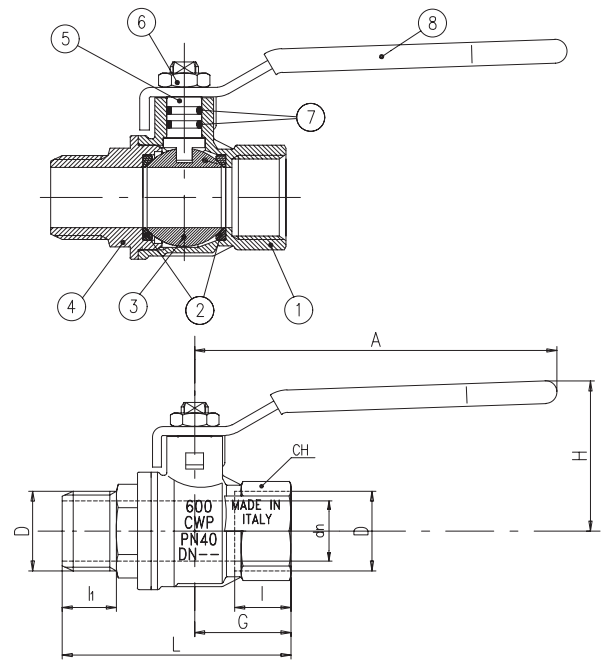

1 1/4"-2" hollow ball

Compliant to CE 2014/68/UE product Equipment category III Module B+D

Code	S84B52	S84C52	S84D52	S84E52	S84F52	S84G52	S84H52	S84I52
D (inch)	1/4"	3/8"	1/2"	3/4"	1"	1 1/4"	1 1/2"	2"
DN (mm)	8	10	15	20	25	32	40	50
I (mm)	12	12	15.5	17	21	23	23	26.5
I1 (mm)	13.5	13.5	16.5	18	22	24	24	27.5
L (mm)	56.5	56.5	70	76.5	92.5	106	113	133
G (mm)	22.5	22.5	29.5	32	40.5	46.5	51	60.5
A (mm)	82	82	100	120	120	158	158	158
H (mm)	38	38	43	50	54	73	79	86
CH (mm)	17	20	25	31	40	49	54	68.5

DN shows the nominal flow diameter. Actual flow diameter complies with full port DIN 3357 part 4. Stem configuration of valves over 2" is slightly different. Ball valves are marked CE on handle from 1 1/4" to 2", on body over 2" as follow:

CE 0425 cat IIIB+D PS: 5 GAS TS1:-20°C TS2: +60°C

PRESSURE-TEMPERATURE CHART

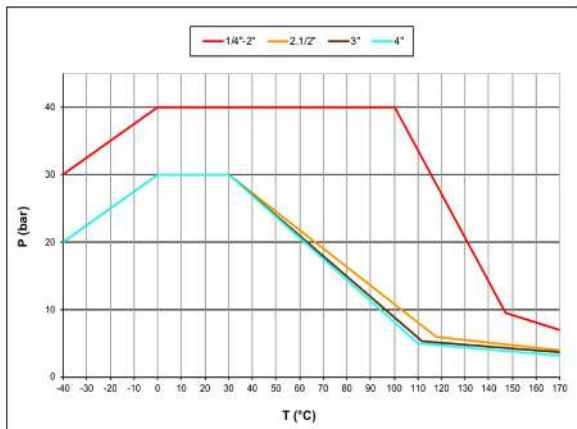

AS4617 limitations for GAS: 2100 Kpa up to 2" and 1500 Kpa from 2 1/2" to 4" rated working pressure and 0°C +60°C temperature

PRESSURE DROP CHART

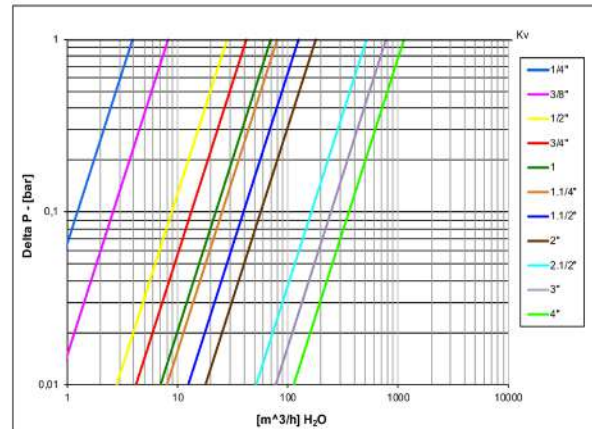



s.84 BSPT T-handle

Female/Female
1/4" - 1 1/2"



H2 READY: product approved in EU acc.to EN331 (sizes 1/4" to 2") for the 1st, 2nd and 3rd gas families, therefore compatible with hydrogen use up to 50% in the gas mixture, as established in the 1st gas family of the EN437 (ref. G110)



QUALITY

- 24h 100% seal test guaranteed
- Dual sealing system allows valve to be operated in either direction making installation easier
- No metal-to-metal moving parts
- No maintenance ever required
- T-Handle clearly shows ball position
- Silicone-free lubricant on all seals
- Chrome plated brass ball for longer life
- Handle stops on body to avoid stresses at stem

BODY

- Hot forged sand blasted, external nickel plated brass body and cap sealed with Loctite® or equivalent thread sealant
- Finest brass according to EN 12165 and EN 12164 specifications

STEM

- Blowout-proof nickel plated brass stem
- Maintenance-free, double FPM O-rings at the stem for maximum safety

SEALING

- Pure PTFE self-lubricating seats with flexible-lip design

THREADS

- EN10226-2, ISO 7/1, BS 21 BSPT taper female by female threads

FLOW

- Full port to DIN 3357 for maximum flow

HANDLE

- Aluminum T-handle up to 1", Geomet® carbon steel T-handle with thick PVC dip coating over 1"
- Handle removable with valve in service
- **WARNING:** do not exceed reasonable temperature and/or electrical load

WORKING PRESSURE & TEMPERATURE

- 40 bar (600 PSI) non-shock cold working pressure
- -40°C to +170°C (-40°F to +350°F)
- For use with dangerous fluids temperature rating is -20°C +60°C and pressure rating is 5 bar
- AS4617 Limitation for GAS: 2100 Kpa rated working pressure and 0°C / +60°C temperature
- **WARNING:** freezing of the fluid in the installation may severely damage the valve

UPON REQUEST

- Stainless steel ball (1.4401 / AISI 316)
- Glass filled PTFE seals
- Custom design

PED DIRECTIVE

- Assessment according to Pressure Equipment Directive 2014/68/UE module B+D by ICIM (0425)

APPROVED BY OR IN COMPLIANCE WITH

- The Australian Gas Association (Australia)
- BSI Group (United Kingdom)
- RoHS Compliant (EU)
- EAC – Declaration of conformity (Russia, Kazakhstan, Belarus)

NOTE: approvals apply to specific configurations/sizes only.

OPTIONS

- Stem extension
- Oval lockable handle **1**
- Patented locking device **2**
- Stainless steel handle (1.4016 / AISI 430) **3**
- Stubby handle **4**
- Geomet® carbon steel handle with thick PVC dip coating
- **RUB** memory stop designed to be installed with our stubby handle



s.84 BSPT T-handle XGES84T - 5966

Each user should perform his own tests to find out the suitability for his particular application. BONOMI INDUSTRIES makes no warranty, express or implied, as to the shape, fit or function of a product for any application. Contact us or consult with your supplier for additional information on the suitability of the BONOMI INDUSTRIES products with your specific field of use.



GAS

Part description	Q.ty	Material
1 Nickel plated body (External nickel plated, unplated inside)	1	CW617N
2 Seat	2	PTFE
3 Chrome plated ball	1	CW617N
4 Nickel plated end cap (External nickel plated, unplated inside)	1	CW617N
5 Nickel plated stem O-ring design	1	CW617N
6 Geomet® nut	1	C4C (EN10263-2)
7 O-Ring	2	FPM
8 Yellow PVC T-handle	1	EN AC-46100
9 Yellow PVC coated Geomet® steel T-handle	1	DD11 (EN10111)

Compliant to CE
2014/68/UE product
Equipment category
III Module B+D

Code	S84B56	S84C56	S84D56	S84E56	S84F56	S84G56	S84H56
D (inch)	1/4"	3/8"	1/2"	3/4"	1"	1 1/4"	1 1/2"
DN (mm)	8	10	15	20	24	32	40
I (mm)	12	12	15.5	17	21	23	23
L (mm)	45	45	59	64	81	93	102
G (mm)	22.5	22.5	29.5	32	40.5	46.5	51
A (mm)	25	25	25	30	30	57	57
H (mm)	39	39	43	49.5	53.5	84.5	90.5
CH (mm)	17	20	25	31	40	49	54

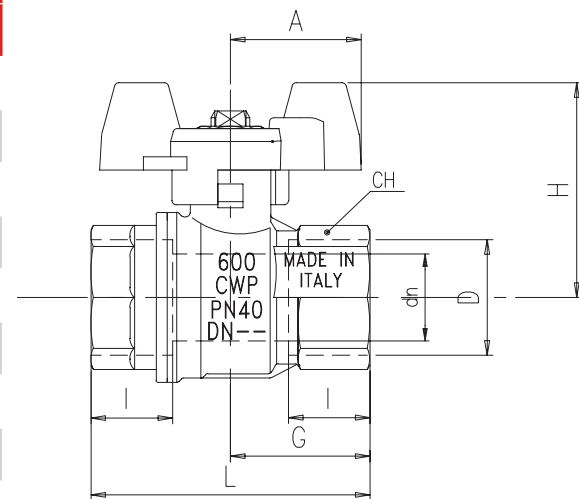
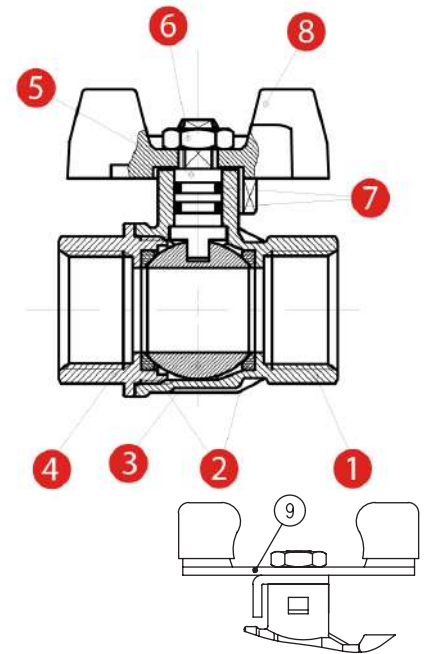

DN shows the nominal flow diameter. Actual flow diameter complies with full port DIN 3357 part 4.

Ball valves are marked CE on body from 1 1/4" to 1 1/2":
CE 0425 cat IIIB+D PS: 5 GAS TS1:-20°C TS2: +60°C

PRESSURE-TEMPERATURE CHART

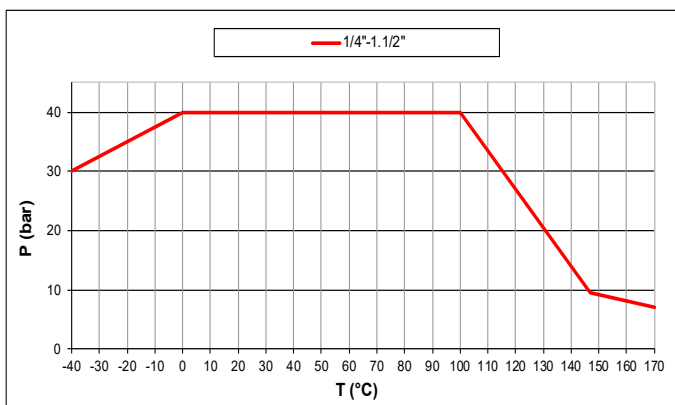

PRESSURE DROP CHART

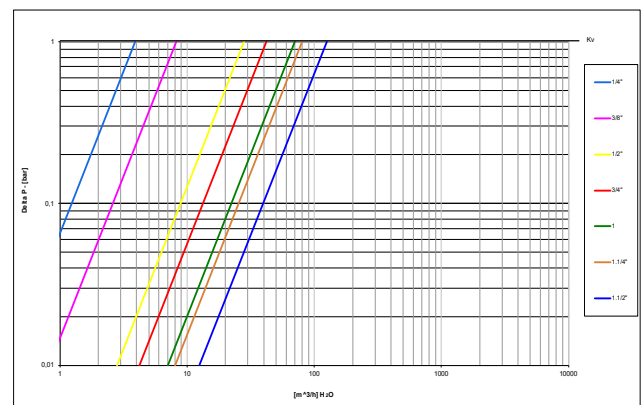

AS4617 limitations for GAS: 2100 Kpa rated working pressure and 0°C +60°C temperature



s.92 NPT

**Female/Female
1/4" - 4"
packing gland**



QUALITY

- 24h 100% seal test guaranteed
- Dual sealing system allows valve to be operated in either direction making installation easier
- No metal-to-metal moving parts
- Handle clearly shows ball position
- Silicone-free lubricant on all seals
- Chrome plated brass ball for longer life
- Handle stops on body to avoid stresses at stem

BODY

- Hot forged sand blasted, unplated brass body and cap sealed with Loctite® or equivalent thread sealant
- Finest brass according to EN 12165 and EN 12164 specifications

STEM

- Blowout-proof nickel plated brass stem
- Pure PTFE adjustable packing gland and reinforced washer for lower torque and easy maintenance
- Triple stem seals in sizes over 2"

SEALING

- Glass filled pure PTFE self-lubricating seats with flexible-lip design

THREADS

- NPT taper ANSI B. 1.20.1 female by female threads

HANDLE

- Geomet® carbon steel handle with thick PVC dip coating. Handle coating offers both thermal and electrical protection
- **WARNING:** do not exceed reasonable temperature and/or electrical load

FLOW

- Full port to DIN 3357 for maximum flow

WORKING PRESSURE & TEMPERATURE

- 600 PSI (40 bar) up to 2", 450 PSI (30 bar) over 2", (150 WSP -10 bar all sizes) non-shock cold working pressure
- 250 PSI (17 bar) non-shock working pressure for LP-Gas
- *150 psig (10 bar) non-shock steam working pressure. Not suitable for throttling steam
- -40°F/+366°F (-40°C / +170°C)

WARNING: freezing of the fluid in the installation may severely damage the valve

UPON REQUEST

- Stainless steel ball and/or stem (1.4401 / AISI 316)
- Custom design
- Pure PTFE seals
- *For sales within EU: CE marking needed, please contact us

APPROVED BY OR IN COMPLIANCE WITH

- Canadian standards Association (United States, Canada)
- Factory Mutual (United States)
- RoHS Compliant (EU)
- EAC – Declaration of conformity (Russia, Kazakhstan, Belarus)
- Underwriters Laboratories (United States, Canada):
 - Guide YSDT: LP-Gas shut-off valve
 - Guide YRBX: Flammable liquid shut-off valve
 - Guide YRPV: Gas shut-off valve for use with natural and manufactured gases
 - Guide MHKZ: No. 6 oil at 250°F
- CRN-TSSA acc. to MSS SP110 (Canada)
- Kuwait Fire Service Directorate (Kuwait)
- Meeting WW-V-35C Federal U.S. Specification (United States)

NOTE: approvals apply to specific configurations/sizes only.

OPTIONS UP TO 2" SIZE

- Oval lockable handle up to 2", round over 2" **1**
- Patented locking device for valves up to 4" **2**
- Stem extension
- Lead free for safe drinking water (0.25% or less Pb)
- Stainless steel handle (1.4016 / AISI 430) **3**
- Stubby handle **4**
- T-handle **5**



s.92 NPT XCES92 - 6012

Each user should perform his own tests to find out the suitability for his particular application. BONOMI INDUSTRIES makes no warranty, express or implied, as to the shape, fit or function of a product for any application. Contact us or consult with your supplier for additional information on the suitability of the BONOMI INDUSTRIES products with your specific field of use.



Part description		Q.ty	Material
1	Unplated NPT body	1	CW617N
2	Seat	2	PTFE glass filled 5-15%
3	Chrome plated ball	1	CW617N
4	Unplated NPT end-cap	1	CW617N
5	Nickel plated stem packing gland design	1	CW617N
6	Nickel plated gland nut	1	CW617N
7	Geomet® nut	1	C4C (EN10263-2)
8	Packing gland seal	1	PTFE
9	Washer	1	PTFE carbon filled 25%
10	Yellow PVC coated Geomet® steel handle	1	DD11 (EN10111)

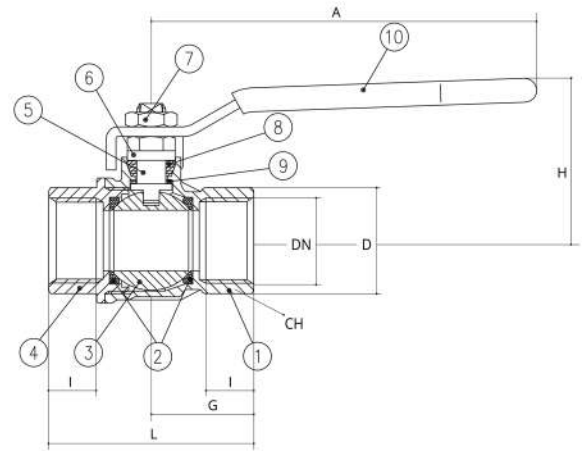

1 1/4"-2" hollow ball

For sales within EU: CE marking needed, please contact us

Code	S92B41	S92C41	S92D41	S92E41	S92F41	S92G41	S92H41	S92I41	S92L41	S92M41	S92N41
D (inch)	1/4"	3/8"	1/2"	3/4"	1"	1 1/4"	1 1/2"	2"	2 1/2"	3"	4"
DN (inch)	0.315	0.374	0.591	0.748	0.945	1.181	1.496	1.890	2.520	2.992	3.937
I (inch)	0.472	0.472	0.61	0.669	0.827	0.906	0.906	1.043	1.26	1.377	1.633
L (inch)	1.772	1.772	2.323	2.520	3.189	3.661	4.016	4.764	6.142	6.969	8.504
G (inch)	0.886	0.886	1.161	1.260	1.594	1.831	2.008	2.382	3.071	3.484	4.252
A (inch)	3.228	3.228	3.937	4.724	4.724	6.22	6.22	6.22	10.039	10.039	10.039
H (inch)	1.563	1.563	1.695	1.988	2.153	2.988	3.236	3.5	5.197	5.512	6.063
CH (inch)	0.669	0.787	0.984	1.22	1.575	1.929	2.126	2.697	3.346	3.898	4.921
Cv (GPM)	4.5	9.5	32.3	48.5	80.9	92.4	144.4	206.8	596.2	896.5	1305.5

DN shows the nominal flow diameter. Actual flow diameter complies with full port DIN 3357 part 4. Stem configuration od valves over 2" is slightly different.

PRESSURE-TEMPERATURE CHART

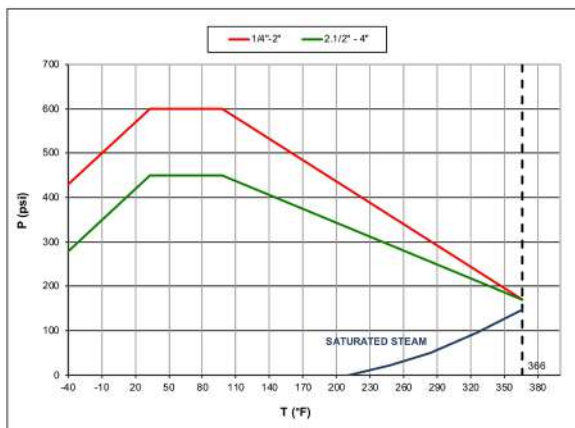

PRESSURE DROP CHART

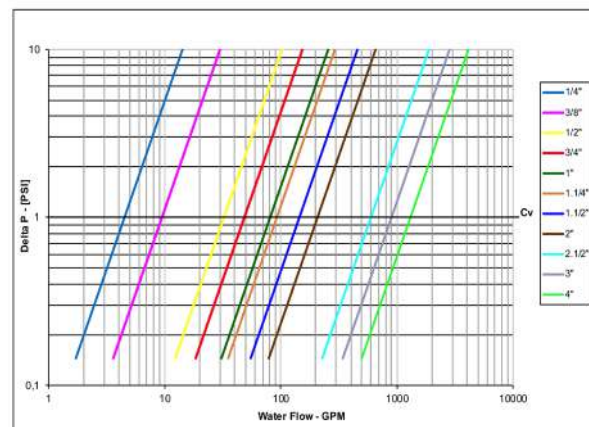



s.92 NPT M/F

Male/Female
1/4" - 4"
packing gland

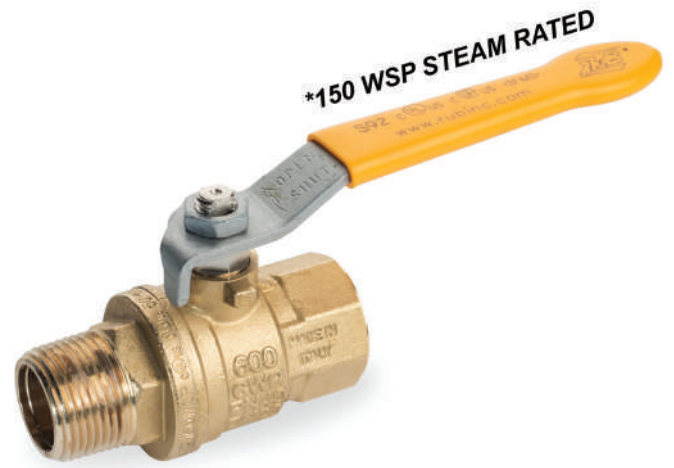

QUALITY

- 24h 100% seal test guaranteed
- Dual sealing system allows valve to be operated in either direction making installation easier
- No metal-to-metal moving parts
- Handle clearly shows ball position
- Silicone-free lubricant on all seals
- Chrome plated brass ball for longer life
- Handle stops on body to avoid stress at stem

BODY

- Hot forged sand blasted, unplated brass body and cap sealed with Loctite® or equivalent thread sealant
- Finest brass according to EN 12165 and EN 12164 specifications

STEM

- Blowout-proof nickel plated brass stem
- Pure PTFE adjustable packing gland and reinforced washer for lower torque and easy maintenance
- Triple stem seals in sizes over 2"

SEALING

- Glass filled pure PTFE self-lubricating seats with flexible-lip design

THREADS

- NPT taper ANSI B.1.20.1 male by female threads

FLOW

- Full port to DIN 3357 for maximum flow

HANDLE

- Geomet® carbon steel handle with thick PVC dip coating. Handle coating offers both thermal and electrical protection
- **WARNING:** do not exceed reasonable temperature and/or electrical load

WORKING PRESSURE & TEMPERATURE

- 600 PSI (40 bar) up to 2", 450 PSI (30 bar) over 2", (150 WSP -10 bar all sizes) non-shock cold working pressure
- 250 PSI (17 bar) non-shock working pressure for LP-Gas
- *150 psig (10 bar) non-shock steam working pressure. Not suitable for throttling steam
- -40°F/+366°F (-40°C / +185°C)
- **WARNING:** freezing of the fluid in the installation may severely damage the valve

UPON REQUEST

- Stainless steel ball and/or stem (1.4401 / AISI 316)
- Custom design
- Pure PTFE seals
- * For sales within EU: CE marking needed, please contact us

APPROVED BY OR IN COMPLIANCE WITH

- Canadian standards Association (United States, Canada)
- Factory Mutual (United States)
- EAC – Declaration of conformity (Russia, Kazakhstan, Belarus)
- RoHS Compliant (EU)
- Meeting WW-V-35C Federal U.S. Specification (United States)
- Underwriters Laboratories (United States, Canada):
 - Guide YSDT: LP-Gas shut-off valve
 - Guide YRBX: Flammable liquid shut-off valve
 - Guide YRPV: Gas shut-off valve for use with natural and manufactured gases
 - Guide MHKZ: No. 6 oil at 250°F

NOTE: approvals apply to specific configurations/sizes only.

OPTIONS UP TO 2" SIZE

- Oval lockable handle up to 2", round over 2" **1**
- Patented locking device for valves up to 4" **2**
- Stem extension
- Stainless steel handle (1.4016 / AISI 430) **3**
- Stubby handle **4**
- T-handle **5**



s.92 NPT M/F XCES92M - 6012

Each user should perform his own tests to find out the suitability for his particular application. BONOMI INDUSTRIES makes no warranty, express or implied, as to the shape, fit or function of a product for any application. Contact us or consult with your supplier for additional information on the suitability of the BONOMI INDUSTRIES products with your specific field of use.



Part description	Q.ty	Material
1 Unplated body	1	CW617N
2 Seat	2	PTFE glass filled 5-15%
3 Chrome plated ball	1	CW617N
4 Unplated NPT end-cap	1	CW617N
5 Nickel plated stem packing gland design	1	CW617N
6 Nickel plated gland nut	1	CW617N
7 Geomet® nut	1	C4C (EN10263-2)
8 Packing gland seal	1	PTFE
9 Washer	1	PTFE carbon filled 25%

1 1/4"-2" hollow ball

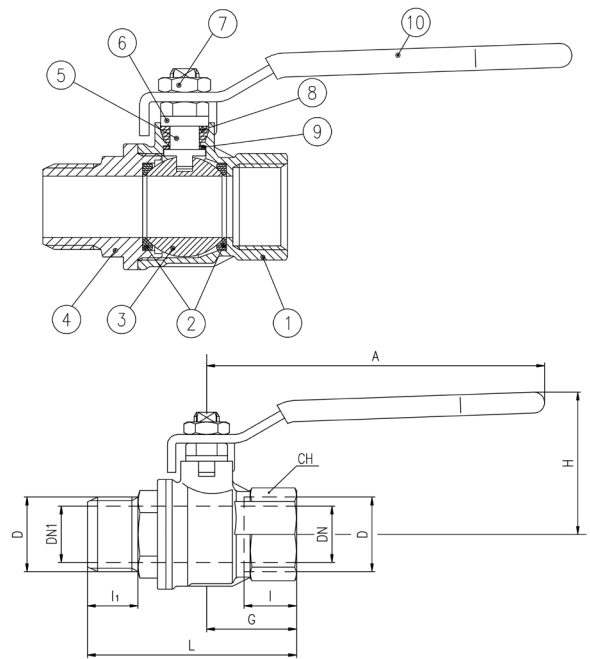

For sales within EU: CE marking needed, please contact us

Code	S92B42	S92C42	S92D42	S92E42	S92F42	S92G42	S92H42	S92I42	S92L42	S92M42	S92N42
D (inch)	1/4"	3/8"	1/2"	3/4"	1"	1 1/4"	1 1/2"	2"	2 1/2"	3"	4"
DN (inch)	0.315	0.374	0.591	0.748	0.945	1.181	1.496	1.890	2.520	2.992	3.937
DN1 (inch)	-	-	-	-	-	-	-	-	2.205	2.756	3.701
I (inch)	0.472	0.472	0.61	0.669	0.827	0.906	0.906	1.043	1.26	1.378	1.634
I1 (inch)	0.531	0.531	0.65	0.709	0.866	0.945	0.945	1.083	1.457	1.555	1.732
L (inch)	2.224	2.224	2.756	2.992	3.642	4.173	4.449	5.236	7.106	8.051	9.37
G (inch)	0.886	0.886	1.161	1.260	1.594	1.831	2.008	2.382	3.071	3.484	4.252
A (inch)	3.228	3.228	3.937	4.724	4.724	6.22	6.22	6.22	10.039	10.039	10.039
H (inch)	1.563	1.563	1.695	1.988	2.153	2.988	3.236	3.5	5.197	5.512	6.063
CH (inch)	0.669	0.787	0.984	1.22	1.575	1.929	2.126	2.697	3.346	3.898	4.921
Cv (GPM)	4.5	9.5	32.3	48.5	80.9	92.4	144.4	206.8	596.2	896.5	1305.5

DN shows the nominal flow diameter. Actual flow diameter complies with full port DIN 3357 part4. Stem configuration of valves over 2" is slightly different.

PRESSURE-TEMPERATURE CHART

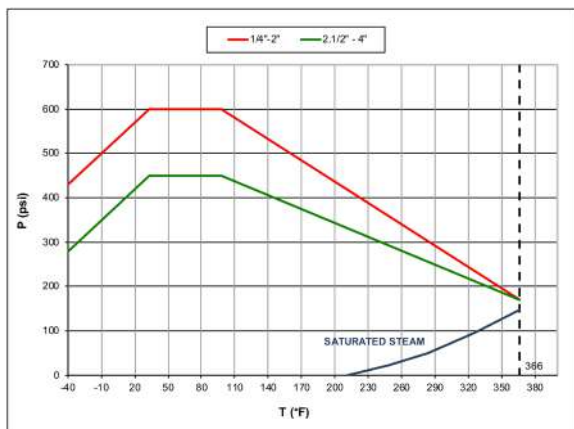

PRESSURE DROP CHART

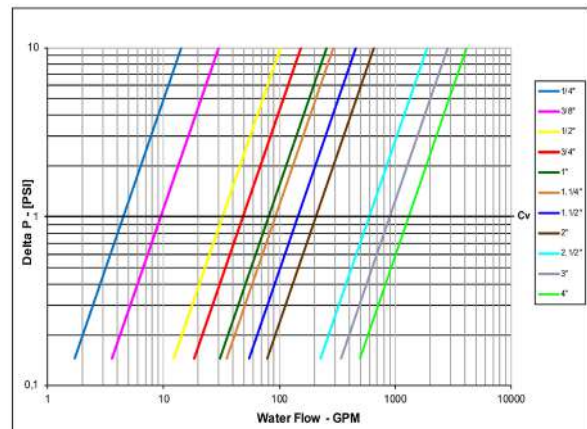



s.95 NPT

Female/Female
1/4" - 4"

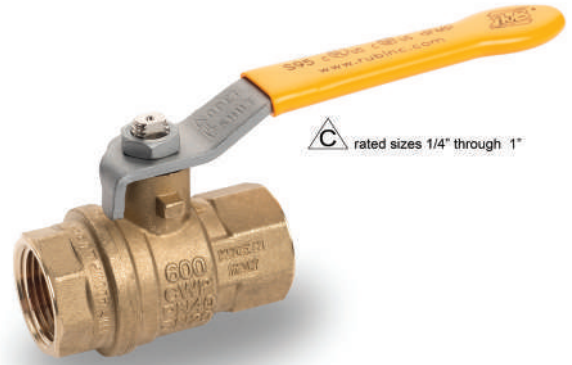

QUALITY

- 24h 100% seal test guaranteed
- Dual sealing system allows valve to be operated in either direction making installation easier
- No metal-to-metal moving parts
- No maintenance ever required
- Handle clearly shows ball position
- Silicone-free lubricant on all seals
- Chrome plated brass ball for longer life
- Handle stops on body to avoid stresses at stem

BODY

- Hot forged sand blasted, unplated brass body and cap sealed with Loctite® or equivalent thread sealant
- Finest brass according to EN 12165 and EN 12164 specifications

STEM

- Blowout-proof nickel plated brass stem
- Maintenance-free, double FPM O-rings at the stem for maximum safety

SEALING

- Pure PTFE self-lubricating seats with flexible-lip design

THREADS

- NPT taper ANSI B.1.20.1 female by female threads

FLOW

- Full port to DIN 3357 for maximum flow

PED DIRECTIVE

- Assessment according to Pressure Equipment Directive 2014/68/UE module B+D by ICIM (0425)

HANDLE

- Geomet® carbon steel handle with thick PVC dip coating. Handle coating offers both thermal and electrical protection
- **WARNING:** do not exceed reasonable temperature and/or electrical load
- Handle removable with valve in service

WORKING PRESSURE & TEMPERATURE

- 600 PSI (40 bar) up to 2", 450 PSI (30 bar) over 2" non-shock cold working pressure
- 250 PSI (17 bar) non-shock working pressure for LP-Gas
- -40°F/+350°F (-40°C / +170°C)
- **WARNING:** freezing of the fluid in the installation may severely damage the valve

UPON REQUEST

- Stainless steel ball (1.4401 / AISI 316)
- Glass filled PTFE seals
- Custom design
- Special configuration for industrial oxygen application

APPROVED BY OR IN COMPLIANCE WITH

- Canadian standards Association (United States, Canada)
- Factory Mutual (United States)
- RoHS Compliant (EU)
- EAC – Declaration of conformity (Russia, Kazakhstan, Belarus)
- Underwriters Laboratories (United States, Canada):
 - Guide YSDT: LP-Gas shut-off valve
 - Guide YRBX: Flammable liquid shut-off valve
 - Guide YRPV: Gas shut-off valve for use with natural and manufactured gases
 - Guide MHKZ: No. 6 oil at 250°F
- CRN-TSSA acc. to MSS SP110 (Canada)
- Meeting WW-V-35C Federal U.S. Specification (United States)

NOTE: approvals apply to specific configurations/sizes only.

OPTIONS UP TO 2" SIZE

- Stem extension
- Oval lockable handle up to 2", round over 2" **1**
- Patented locking device for valves up to 4" **2**
- Stainless steel handle (1.4016 / AISI 430) **3**
- **RuB** memory stop designed to be installed with our stubby handle
- Stubby handle **4**
- T-handle **5**



s.95 NPT XCES95 - 6012

Each user should perform his own tests to find out the suitability for his particular application. BONOMI INDUSTRIES makes no warranty, express or implied, as to the shape, fit or function of a product for any application. Contact us or consult with your supplier for additional information on the suitability of the BONOMI INDUSTRIES products with your specific field of use.



Part description		Q.ty	Material
1	Unplated NPT body	1	CW617N
2	Seat	2	PTFE
3	Chrome plated ball	1	CW617N
4	Unplated NPT end-cap	1	CW617N
5	Nickel plated stem O-ring design	1	CW617N
6	Geomet® nut	1	C4C (EN10263-2)
7	O-Ring	2	FPM
8	Yellow PVC coated Geomet® steel handle	1	DD11 (EN10111)

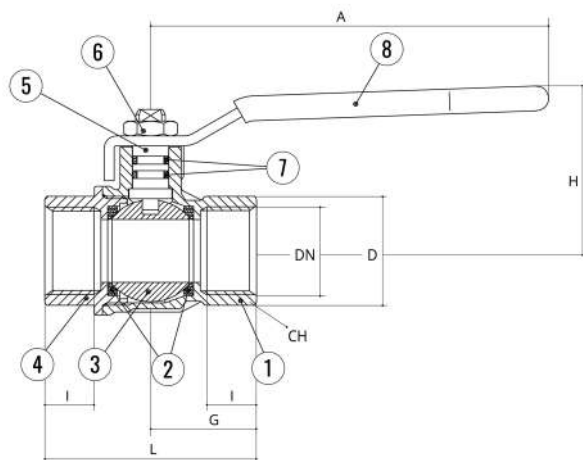

1 1/4"-2" hollow ball

For sales within EU: CE marking needed, use following codes:

S95G41CE S95H41CE S95I41CE S95L41CE S95M41CE S95N41CE

Code	S95B41	S95C41	S95D41	S95E41	S95F41	S95G41	S95H41	S95I41	S95L41	S95M41	S95N41
D (inch)	1/4"	3/8"	1/2"	3/4"	1"	1 1/4"	1 1/2"	2"	2 1/2"	3"	4"
DN (inch)	0.315	0.374	0.591	0.748	0.945	1.181	1.496	1.890	2.520	2.992	3.937
I (inch)	0.472	0.472	0.610	0.669	0.827	0.906	0.906	1.043	1.260	1.377	1.633
L (inch)	1.772	1.772	2.323	2.520	3.189	3.661	4.016	4.764	6.142	6.969	8.504
G (inch)	0.886	0.886	1.162	1.260	1.594	1.831	2.008	2.382	3.071	3.484	4.252
A (inch)	3.228	3.228	3.937	4.724	4.724	6.220	6.220	6.220	10.039	10.039	10.039
H (inch)	1.480	1.480	1.679	1.956	2.114	2.858	3.094	3.370	5.197	5.512	6.063
CH (inch)	0.669	0.787	0.984	1.220	1.575	1.929	2.126	2.697	3.346	3.898	4.921
Cv (GPM)	4.5	9.5	32.3	48.5	80.9	92.4	144.4	206.8	596.2	896.5	1305.5

DN shows the nominal flow diameter. Actual flow diameter complies with full port DIN 3357 part 4. Stem configuration of valves over 2" is slightly different. For sales within EU: ball valves are marked CE on handle from 1 1/4" to 2", on body over 2" as follow: CE 0425 cat IIIB+D PS: 5 GAS TS1: -20°C TS2: +60°C

PRESSURE-TEMPERATURE CHART

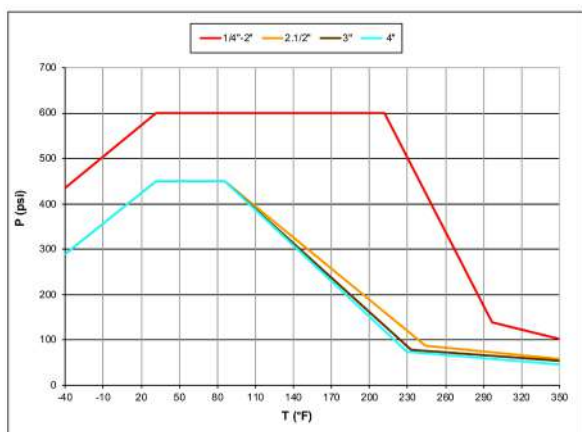

PRESSURE DROP CHART

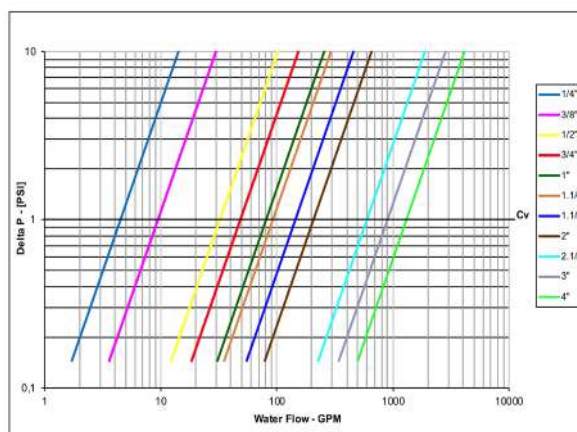



s.95 NPT T-handle

Female/Female
1/4" - 2"



rated sizes 1/4" through 1"



QUALITY

- 24h 100% seal test guaranteed
- Dual sealing system allows valve to be operated in either direction making installation easier
- No metal-to-metal moving parts
- No maintenance ever required
- Handle clearly shows ball position
- Silicone-free lubricant on all seals
- Chrome plated brass ball for longer life
- Handle stops on body to avoid stresses at stem

BODY

- Hot forged sand blasted, unplated brass body and cap sealed with Loctite® or equivalent thread sealant
- Finest brass according to EN 12165 and EN 12164 specifications

STEM

- Blowout-proof nickel plated brass stem
- Maintenance-free, double FPM O-rings at the stem for maximum safety

SEALING

- Pure PTFE self-lubricating seats with flexible-lip design

THREADS

- NPT taper ANSI B.1.20.1 female by female threads

FLOW

- Full port to DIN 3357 for maximum flow

PED DIRECTIVE

- Assessment according to Pressure Equipment Directive 2014/68/UE module B+D by ICIM (0425)

OPTIONS

- Stem extension
- Oval lockable handle **1**
- Patented locking device **2**
- Geomet® carbon steel handle with thick PVC dip coating
- Stainless steel handle (1.4016 / AISI 430) **3**
- **RuB** memory stop designed to be installed with our stubby handle
- Stubby handle **4**

HANDLE

- Aluminium T-handle, painted yellow up to 1", Geomet® steel T-handle with PVC dip coating for 1 1/4" - 2" sizes
- **WARNING:** do not exceed reasonable temperature and/or electrical load
- Handle removable with valve in service

WORKING PRESSURE & TEMPERATURE

- 600 PSI (40 bar) non-shock cold working pressure
- 250 PSI (17 bar) non-shock working pressure for LP-Gas
- -40°F/+350°F (-40°C / +170°C)
- **WARNING:** freezing of the fluid in the installation may severely damage the valve

UPON REQUEST

- Stainless steel ball (1.4401 / AISI 316)
- Glass filled PTFE seals
- Custom design
- Special configuration for industrial oxygen application

APPROVED BY OR IN COMPLIANCE WITH

- Canadian standards Association (United States, Canada)
- Factory Mutual (United States)
- RoHS Compliant (EU)
- EAC – Declaration of conformity (Russia, Kazakhstan, Belarus)
- Underwriters Laboratories (United States, Canada):
 - Guide YSDT: LP-Gas shut-off valve
 - Guide YRBX: Flammable liquid shut-off valve
 - Guide YRPV: Gas shut-off valve for use with natural and manufactured gases
 - Guide MHKZ: No. 6 oil at 250°F
- CRN-TSSA acc. to MSS SP110 (Canada)
- Meeting WW-V-35C Federal U.S. Specification (United States)

NOTE: approvals apply to specific configurations/sizes only.



s.95 NPT T-handle XCES9546 - 6012

Each user should perform his own tests to find out the suitability for his particular application. BONOMI INDUSTRIES makes no warranty, express or implied, as to the shape, fit or function of a product for any application. Contact us or consult with your supplier for additional information on the suitability of the BONOMI INDUSTRIES products with your specific field of use.



Part description	Q.ty	Material
1 Unplated NPT body	1	CW617N
2 Seat	2	PTFE
3 Chrome plated ball	1	CW617N
4 Unplated NPT end-cap	1	CW617N
5 Nickel plated stem O-ring design	1	CW617N
6 Geomet® nut	1	C4C (EN10263-2)
7 O-Ring	2	FPM
8 Yellow T-handle	1	EN AC-46100 (EN1676)
9 Geomet® steel T-handle	1	DD01 (EN10111)
10 Yellow dipped coating	2	PVC

1 1/4"-2" hollow ball

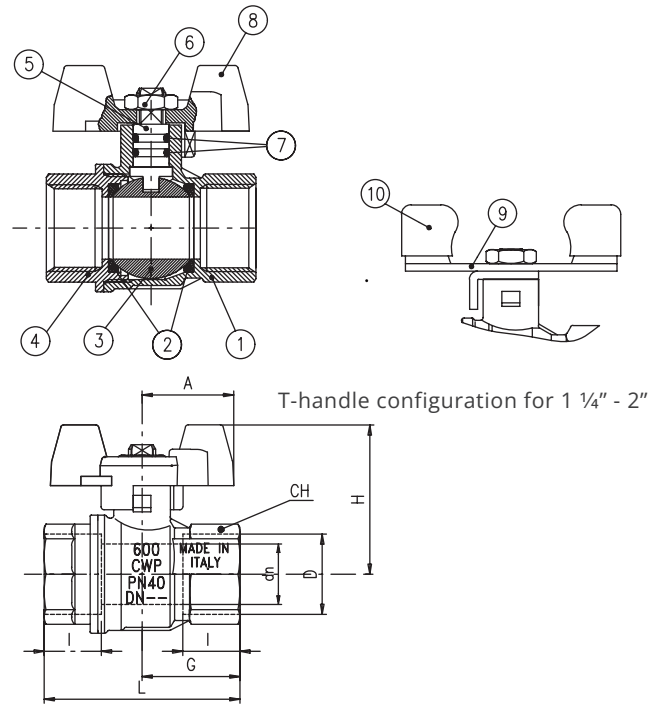

For sales within EU: CE marking needed, use following codes:

S95G46CE S95H46CE S95I46CE

Code	S95B46	S95C46	S95D46	S95E46	S95F46	S95G46	S95H46	S95I46
D (inch)	1/4"	3/8"	1/2"	3/4"	1"	1 1/4"	1 1/2"	2"
DN (mm)	0.315	0.374	0.591	0.748	0.945	1.181	1.496	1.890
I (mm)	0.472	0.472	0.610	0.669	0.827	0.906	0.906	1.043
L (mm)	1.772	1.772	2.323	2.520	3.189	3.661	4.016	4.764
G (mm)	0.886	0.886	1.131	1.260	1.594	1.831	2.008	2.382
A (mm)	0.984	0.984	0.984	1.181	1.181	2.244	2.244	2.244
H (mm)	1.535	1.535	1.692	1.850	2.008	3.326	3.562	3.838
CH (mm)	0.669	0.787	0.984	1.220	1.575	1.929	2.126	2.697
Cv (GPM)	4.5	9.5	32.3	48.5	80.9	92.4	144.4	206.8

DN shows the nominal flow diameter. Actual flow diameter complies with full port DIN 3357 part 4.

For sales within EU: ball valves are marked CE from 1 1/4" to 2" as follow:

CE 0425 cat IIIB+D PS: 5 GAS TS1: -20°C TS2: +60°C

PRESSURE-TEMPERATURE CHART

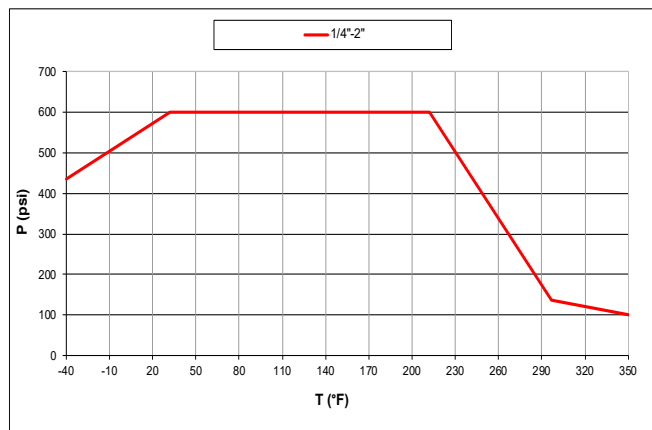

PRESSURE DROP CHART

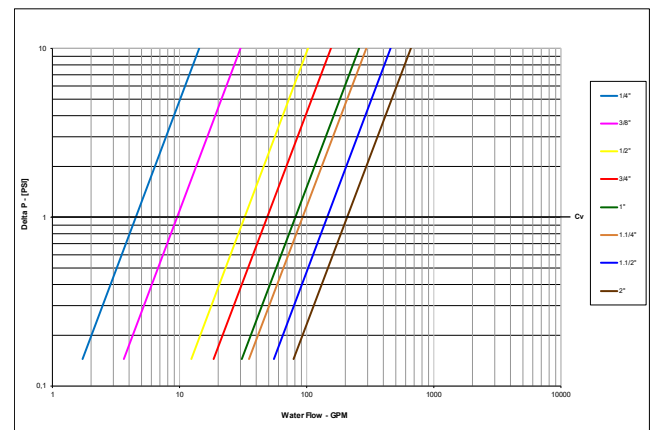



s.95 NPT nickel plated

Female/Female
1/4" - 4"



QUALITY

- 24h 100% seal test guaranteed
- Dual sealing system allows valve to be operated in either direction making installation easier
- No metal-to-metal moving parts
- No maintenance ever required
- Handle clearly shows ball position
- Silicone-free lubricant on all seals
- Chrome plated brass ball for longer life
- Handle stops on body to avoid stress at stem

BODY

- Hot forged sand blasted, nickel plated brass body and cap sealed with Loctite® or equivalent thread sealant
- Finest brass according to EN 12165 and EN 12164 specifications

STEM

- Blowout-proof nickel plated brass stem
- Maintenance-free, double FPM O-rings at the stem for maximum safety

SEALING

- Pure PTFE self-lubricating seats with flexible-lip design

THREADS

- NPT taper ANSI B.1.20.1 female by female threads

FLOW

- Full port to DIN 3357 for maximum flow

PED DIRECTIVE

- Assessment according to Pressure Equipment Directive 2014/68/UE module B+D by ICIM (0425)

HANDLE

- Geomet® carbon steel handle with thick PVC dip coating. Handle coating offers both thermal and electrical protection
- Handle removable with valve in service
- **WARNING:** do not exceed reasonable temperature and/or electrical load

WORKING PRESSURE & TEMPERATURE

- 600 PSI (40 bar) up to 2", 450 PSI (30 bar) over 2" non-shock cold working pressure
- 250 PSI (17 bar) non-shock working pressure for LP-Gas
- -40°F/+350°F (-40°C / +170°C)
- **WARNING:** freezing of the fluid in the installation may severely damage the valve

UPON REQUEST

- Stainless steel ball (1.4401 / AISI 316)
- Glass filled PTFE seals
- Custom design
- Special configuration for industrial oxygen application

APPROVED BY OR IN COMPLIANCE WITH

- Canadian standards Association (United States, Canada)
- Factory Mutual (United States)
- RoHS Compliant (EU)
- EAC – Declaration of conformity (Russia, Kazakhstan, Belarus)
- Underwriters Laboratories (United States, Canada):
 - Guide YSDT: LP-Gas shut-off valve
 - Guide YRBX: Flammable liquid shut-off valve
 - Guide YRPV: Gas shut-off valve for use with natural and manufactured gases
 - Guide MHKZ: No. 6 oil at 250°F

NOTE: approvals apply to specific configurations/sizes only.

OPTIONS UP TO 2" SIZE

- Stem extension
- Oval lockable handle up to 2", round over 2" **1**
- Patented locking device for valves up to 4" **2**
- Stainless steel handle (1.4016 / AISI 430) **3**
- **RuB** memory stop designed to be installed with our stubby handle
- Stubby handle **4**
- T-handle **5**



s.95 NPT NICKEL PLATED XGES95N - 6012

Each user should perform his own tests to find out the suitability for his particular application. BONOMI INDUSTRIES makes no warranty, express or implied, as to the shape, fit or function of a product for any application. Contact us or consult with your supplier for additional information on the suitability of the BONOMI INDUSTRIES products with your specific field of use.



Part description		Q.ty	Material
1	Nickel plated NPT body	1	CW617N
2	Seat	2	PTFE
3	Chrome plated ball	1	CW617N
4	Nickel plated NPT end-cap	1	CW617N
5	Nickel plated stem O-ring design	1	CW617N
6	Geomet® nut	1	C4C (EN10263-2)
7	O-Ring	2	FPM
8	Yellow PVC coated Geomet® steel handle	1	DD11 (EN10111)

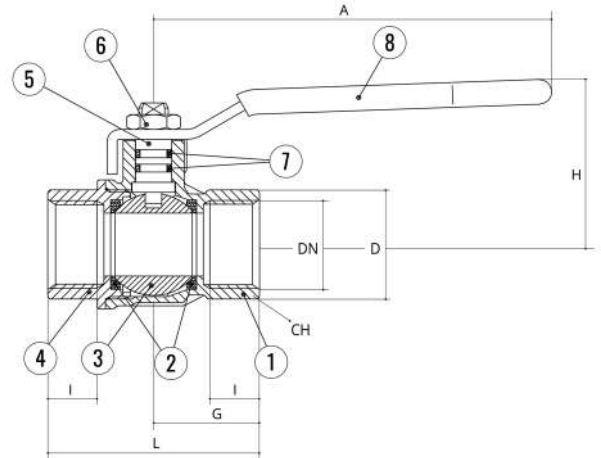

1 1/4"-2" hollow ball

For sales within EU: CE marking needed, use following codes:
S95G41NCE S95H41NCE S95I41NCE S95L41NCE S95M41NCE S95N41NCE

Code	S95B41N	S95C41N	S95D41N	S95E41N	S95F41N	S95G41N	S95H41N	S95I41N	S95L41N	S95M41N	S95N41N
D (inch)	1/4"	3/8"	1/2"	3/4"	1"	1 1/4"	1 1/2"	2"	2 1/2"	3"	4"
DN (inch)	0.315	0.374	0.591	0.748	0.945	1.181	1.496	1.890	2.520	2.992	3.937
I (inch)	0.472	0.472	0.610	0.669	0.827	0.906	0.906	1.043	1.260	1.377	1.633
L (inch)	1.772	1.772	2.323	2.520	3.189	3.661	4.016	4.764	6.142	6.969	8.504
G (inch)	0.886	0.886	1.161	1.260	1.594	1.831	2.008	2.382	3.071	3.484	4.252
A (inch)	3.228	3.228	3.937	4.724	4.724	6.220	6.220	6.220	10.039	10.039	10.039
H (inch)	1.480	1.480	1.679	1.956	2.114	2.858	3.094	3.370	5.197	5.512	6.063
CH (inch)	0.669	0.787	0.984	1.220	1.575	1.929	2.126	2.697	3.346	3.898	4.921
Cv (GPM)	4.5	9.5	32.3	48.5	80.9	92.4	144.4	206.8	596.2	896.5	1305.5

DN shows the nominal flow diameter. Actual flow diameter complies with full port DIN 3357 part 4. Stem configuration of valves over 2" is slightly different.

PRESSURE-TEMPERATURE CHART

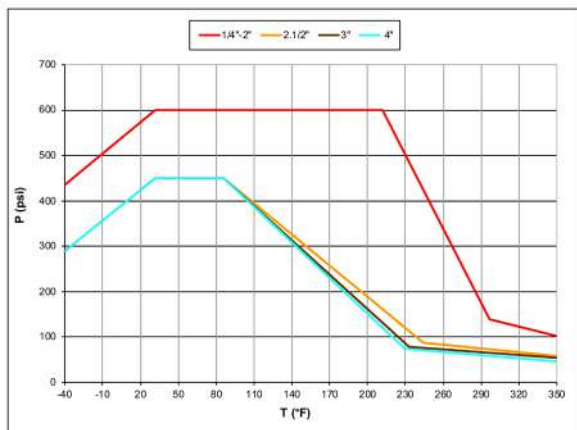

PRESSURE DROP CHART

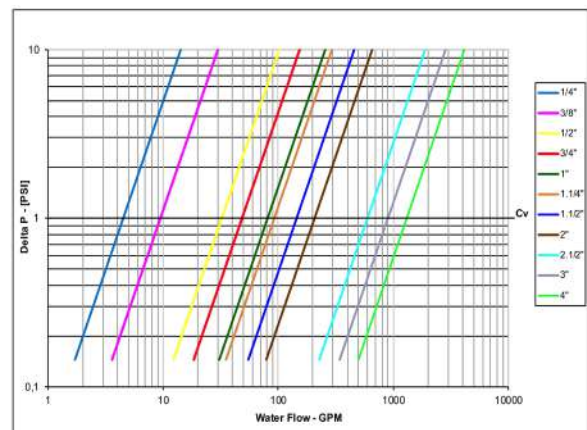



s.128A

Female/Female 3/4" Y-strainer



QUALITY

- Suitable for gas, industrial, pneumatic and hydraulic installations

BODY

- Hot forged sand blasted, nickel plated brass body
- Stainless steel (1.4301 / AISI 304) filter
- Degree of filtration: 50µm

THREADS

- ISO 228/1 female by female parallel threads and inspection plug

WORKING PRESSURE & TEMPERATURE

- 6 bar non-shock cold working pressure
- -40°C to +60°C (-40°F to +140°F)
- **WARNING:** freezing of the fluid in the installation may severely damage the valve

s.128A XCE128A - 5466

Each user should perform his own tests to find out the suitability for his particular application. BONOMI INDUSTRIES makes no warranty, express or implied, as to the shape, fit or function of a product for any application. Contact us or consult with your supplier for additional information on the suitability of the BONOMI INDUSTRIES products with your specific field of use.



	Part description	Q.ty	Material
1	Nickel plated end-cap	1	CW617N
2	Nickel plated body	1	CW617N
3	O-ring	1	NBR
4	Stainless steel strainer 50µm	1	1.4301 / AISI 304

D (inch)	3/4"
A (mm)	70
B (mm)	48
DN	20

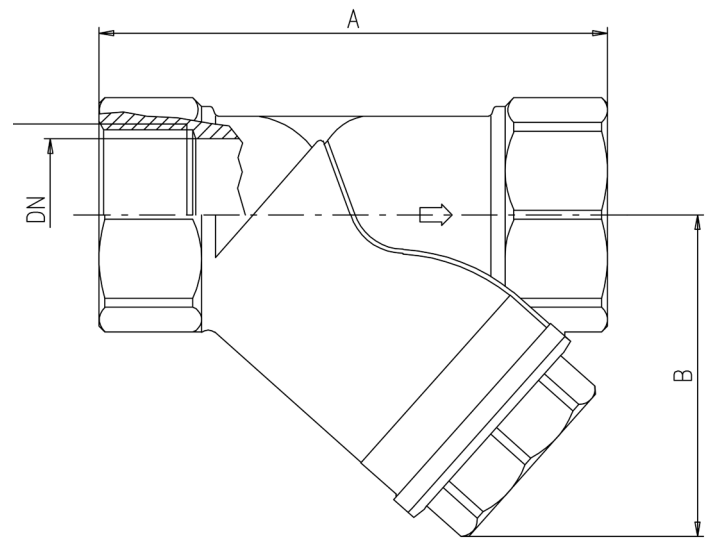
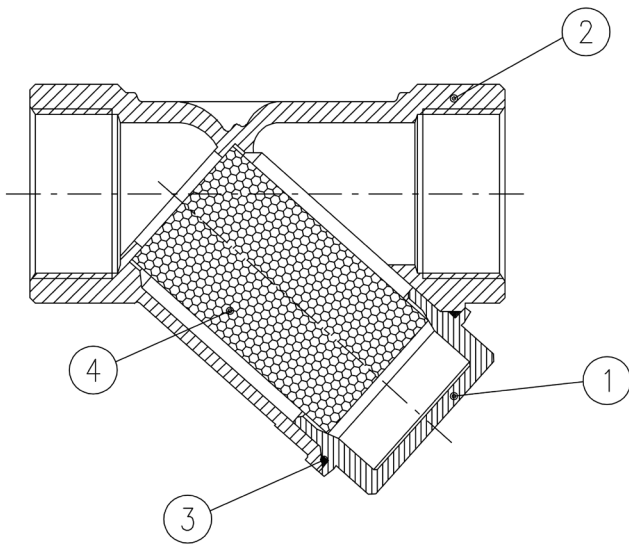



s.195 NPT

**Female/Female
3/8" - 1" standard port gas cock**



QUALITY

- 24h 100% seal test guaranteed
- Dual sealing system allows valve to be operated in either direction making installation easier
- No metal-to-metal moving parts
- No maintenance ever required
- Handle clearly shows ball position
- Silicone-free lubricant on all seals
- Handle stops on body to avoid stresses at stem
- Chrome plated brass ball for longer life

BODY

- Hot forged sand blasted, unplated brass body and cap sealed with Loctite® or equivalent thread sealant
- Finest brass according to EN 12165 and EN 12164 specifications

STEM

- Blowout-proof nickel plated brass stem
- Maintenance-free, double FPM O-rings at the stem for maximum safety

SEALING

- Pure PTFE self-lubricating seats with flexible-lip design

THREADS

- NPT taper ANSI B.1.20.1 female by female threads

FLOW

- Standard port for compact design

HANDLE

- Aluminum wedge handle enameled red
- **WARNING:** do not exceed reasonable temperature and/or electrical load
- Handle removable with valve in service

WORKING PRESSURE & TEMPERATURE

- 450 PSI (30 bar) non-shock cold working pressure
- 250 PSI (17 bar) non-shock working pressure for LP-Gas
- -40°F to +350°F (-40°C / +170°C)
- **WARNING:** freezing of the fluid in the installation may severely damage the valve

APPROVED BY OR IN COMPLIANCE WITH

- Underwriters Laboratories (United States, Canada):
 - Guide YSDT: LP-Gas shut-off valve
 - Guide YRBX: Flammable liquid shut-off valve
 - Guide YRPV: Gas shut-off valve for use with natural and manufactured gases
 - Guide MHKZ: No. 6 oil at 250°F
- EAC – Declaration of conformity (Russia, Kazakhstan, Belarus)
- Canadian standards Association (United States, Canada)
- RoHS Complaint (EU)
- Meeting WW-V-35C Federal U.S. Specification (United States)

NOTE: approvals apply to specific configurations/sizes only.

OPTIONS

- Stem extension
- T-handle
- Stainless steel handle (1.4016 / AISI 430)
- 3/8" through 1" NPT female by NPT female (suffix 41)
- 3/8", 1/2" and 5/8" flare by flare (suffix 30)
- 1/2" NPT female by 1/2" flare (suffix 31)
- 1/2" NPT male by 1/2" flare (suffix 34)
- 1/2" NPT male by 3/8" flare (suffix 34)
- 1/2" NPT female by 3/8" flare (suffix 33)
- 1/2" flare by 3/8" flare (suffix 32)
- 1/8" NPT side tap for some versions/ sizes



s.195 NPT XCE195 - 5813

Each user should perform his own tests to find out the suitability for his particular application. BONOMI INDUSTRIES makes no warranty, express or implied, as to the shape, fit or function of a product for any application. Contact us or consult with your supplier for additional information on the suitability of the BONOMI INDUSTRIES products with your specific field of use.



Part description		Q.ty	Material
1	Sand blasted unplated body	1	CW617N
2	Seat	2	PTFE
3	Chrome plated ball	1	CW617N
4	Sand blasted unplated end-cap	1	CW617N
5	Nickel plated stem O-ring design	1	CW617N
6	Geomet® nut	1	C4C (EN10263-2)
7	O-Ring	2	FPM
8	Red T-handle	1	EN AC- 46100

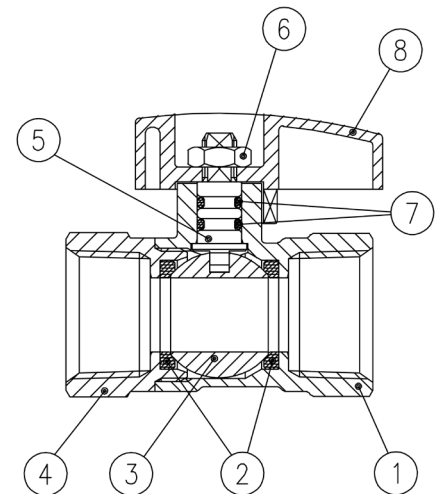

Code	195C41	195D41	195E41	195F41
D (inch)	3/8"	1/2"	3/4"	1"
DN (inch)	0.374	0.453	0.590	0.748
I (inch)	0.472	0.610	0.669	0.827
L (inch)	1.772	2.126	2.441	2.835
G (inch)	0.886	1.043	1.220	1.417
A (inch)	1.299	1.299	1.299	1.575
H (inch)	1.437	1.535	1.614	1.850
CH (inch)	0.787	0.984	1.220	1.496
Cv (GPM)	9.5	8.3	15.0	22.0

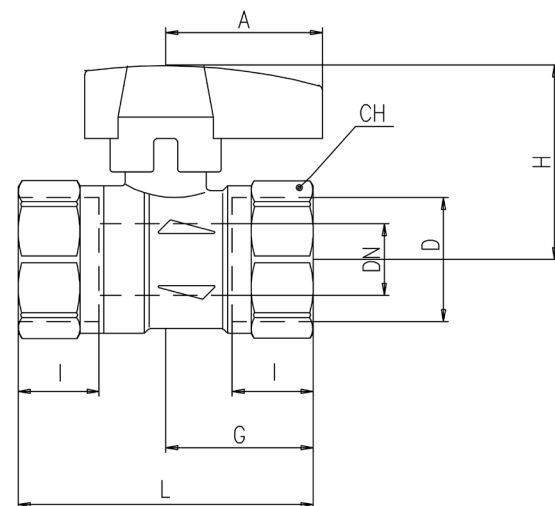

DN shows the nominal flow diameter.

PRESSURE-TEMPERATURE CHART

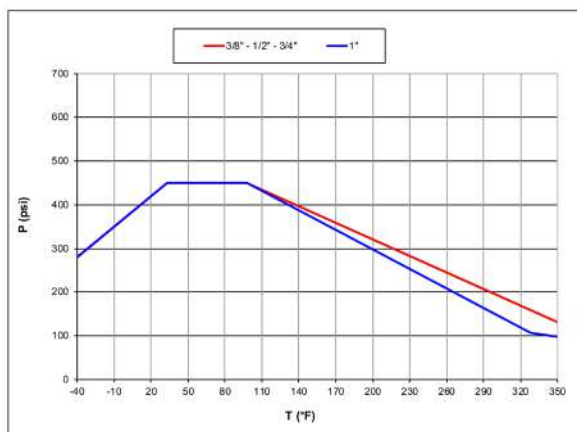

PRESSURE DROP CHART

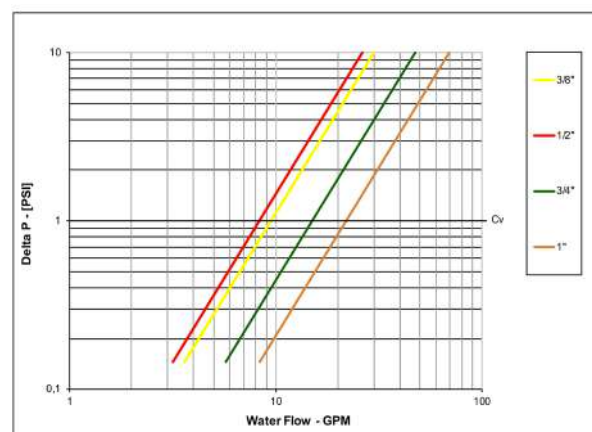



s.195 & flare

**Female/Female
flare 37°
by solder end 1/2" – 3/4", standard port**



QUALITY

- 24h 100% seal test guaranteed
- Dual sealing system allows valve to be operated in either direction making installation easier
- No metal-to-metal moving parts
- Handle clearly shows ball position
- Silicone-free lubricant on all seals
- Handle stops on body to avoid stresses at stem
- Chrome plated brass ball for longer life

BODY

- Hot forged sand blasted, unplated brass body and cap sealed with Loctite® or equivalent thread sealant
- Finest brass according to EN 12165 and EN 12164 specifications

STEM

- Blowout-proof nickel plated brass stem
- Pure PTFE adjustable packing gland and reinforced washer for lower torque and easy maintenance

SEALING

- Pure PTFE self-lubricating seats with flexible-lip design

THREADS

- 1/2" flare 37° by 1/2" solder end
- 3/4" flare 37° by 3/4" solder end

FLOW

- Standard port for compact design

HANDLE

- Aluminum T-handle enameled red
- **WARNING:** do not exceed reasonable temperature and/or electrical load

WORKING PRESSURE & TEMPERATURE

- 600 PSI (for solder joints rating see table 1) non-shock cold working pressure
- -4°F to +350°F (for solder joints rating see table 1)
- **WARNING:** freezing of the fluid in the installation may severely damage the valve

APPROVED BY OR IN COMPLIANCE WITH

- EAC – Declaration of conformity (Russia, Kazakhstan, Belarus)
- Canadian standards Association (United States, Canada)
- RoHS Compliant (EU)

NOTE: approvals apply to specific configurations/sizes only.

OPTIONS

- Stainless steel handle (1.4016 / AISI 430)
- Geomet® carbon steel handle with thick PVC dip coating. Handle coating offers both thermal and electrical protection
- Stubby handle
- Upon request
- Memory stop

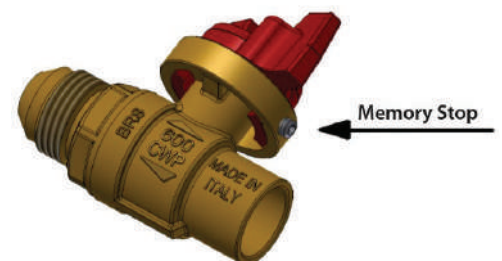

s.195 NPT & FLARE XCE19540 - 5813

Each user should perform his own tests to find out the suitability for his particular application. BONOMI INDUSTRIES makes no warranty, express or implied, as to the shape, fit or function of a product for any application. Contact us or consult with your supplier for additional information on the suitability of the BONOMI INDUSTRIES products with your specific field of use.



Part description	Q.ty	Material
1 Sand blasted unplated body	1	CW617N
2 Seat	2	PTFE
3 Chrome plated ball	1	CW617N
4 Sand blasted unplated end-cap	1	CW617N
5 Nickel plated stem packing gland design	1	CW617N
6 Packing gland seal	1	PTFE
7 Nickel plated gland nut	1	CW617N
8 Geomet® nut	1	C4C (EN10263-2)
9 Washer	1	PTFE carbon filled 25%
10 Red T-handle	1	EN AC- 46100

Code	195D40	195E40
D (inch)	0.63"	0.877"
D1 (inch)	3/4-16 UNF 2A	1.1/16-12 UN 2A
DN (inch)	0.39	0.61
I (inch)	0.49	0.748
I1 (inch)	0.66	0.862
L (inch)	2.33	3.031
G (inch)	0.94	1.319
A (inch)	0.98	0.98
H (inch)	1.63	1.705
Cv (GPM)	5.8	14.5

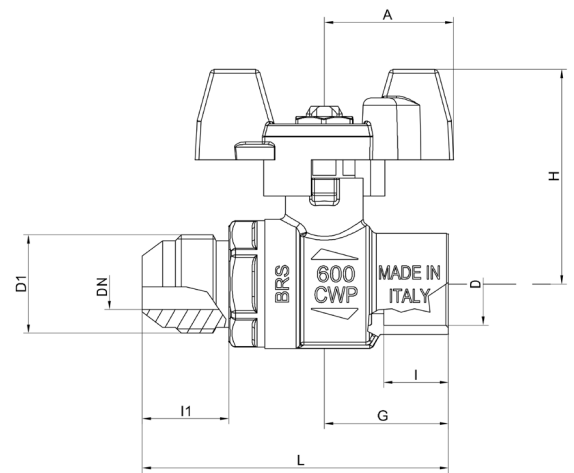
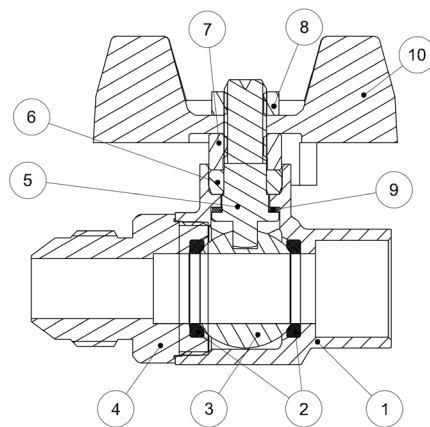

DN shows the nominal flow diameter.

TABLE 1 PRESSURE - TEMPERATURE RATINGS

Joining material	Melting range degrees		Working temperature degrees		Maximum working gauge pressure					
					Size 1/8" - 1"		Size 1 1/4" - 2"		Size 2 1/2" - 4"	
	°F	°C	°F	°C	PSI	kPa	PSI	kPa	PSI	kPa
50-50 tin-lead solder* ASTM B32 alloy grade 50 A	361/421	185/215	0/+100	-18/+38	200	1400	176	1200	150	1050
			0/+150	-18/+66	150	1050	125	850	100	700
			0/+200	-18/+93	100	700	90	600	75	500
			0/+250	-18/+121	85	600	75	500	50	350
95-5 tin-antimony solder ASTM B32 alloy grade 95TA	450/464	230/240	0/+100	-18/+38	500**	3500**	400**	2800**	300**	2100**
			0/+150	-18/+66	400**	2800**	350**	2400**	275**	2000**
			0/+200	-18/+93	300**	2100**	250**	1700**	200	1400
			0/+250	-18/+121	200	1400	175	1200	150	1050

Note:

Above stated limits are not imposed by the valve, but by the strength of the soldering joint according to ASME B16.22.

* This alloy contains more than 0,2% lead and, according to certain specifications, cannot be used for potable water or other foods.

** Soldered copper tube joints have been tested at 230 PSI (1600 kPa) in accordance with ISO 2016

PRESSURE-TEMPERATURE CHART

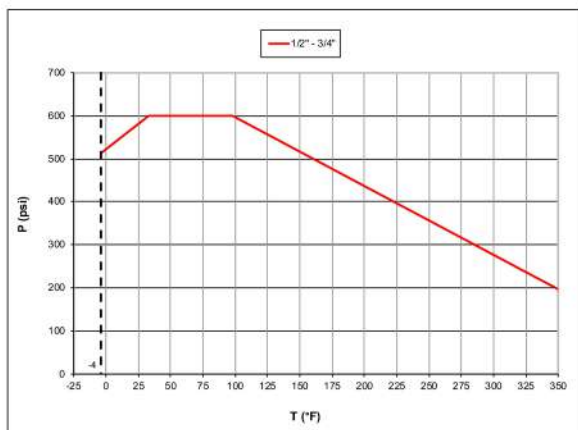

PRESSURE DROP CHART

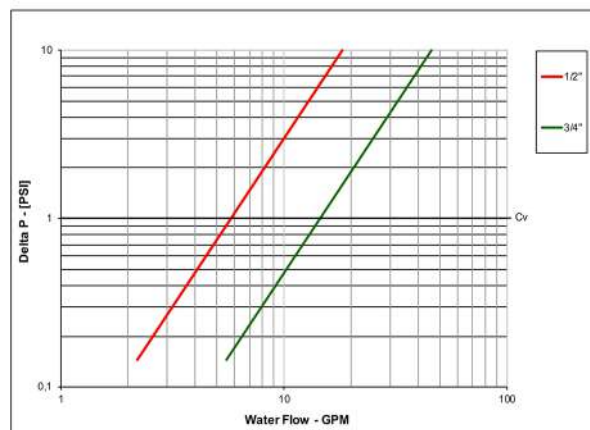

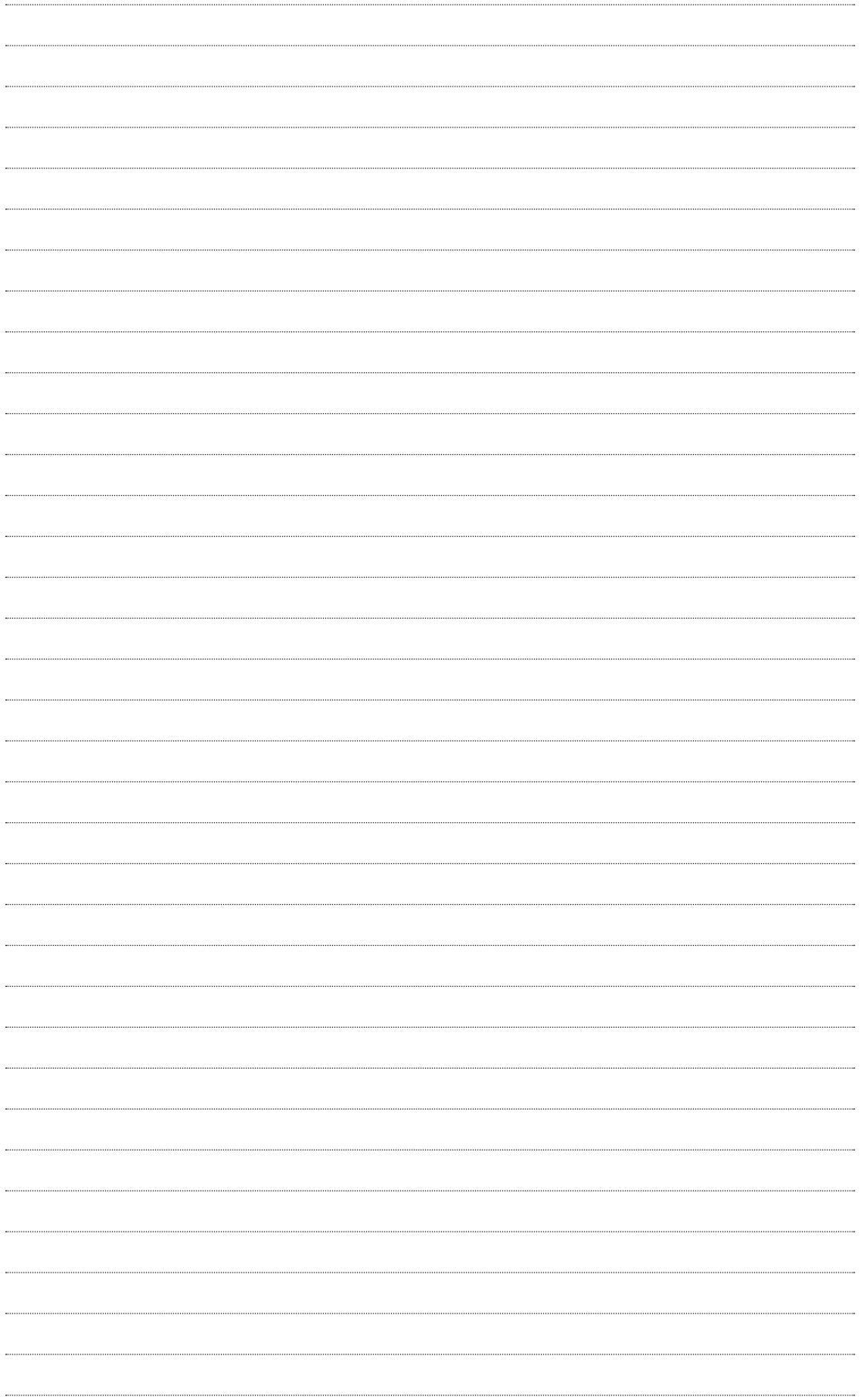

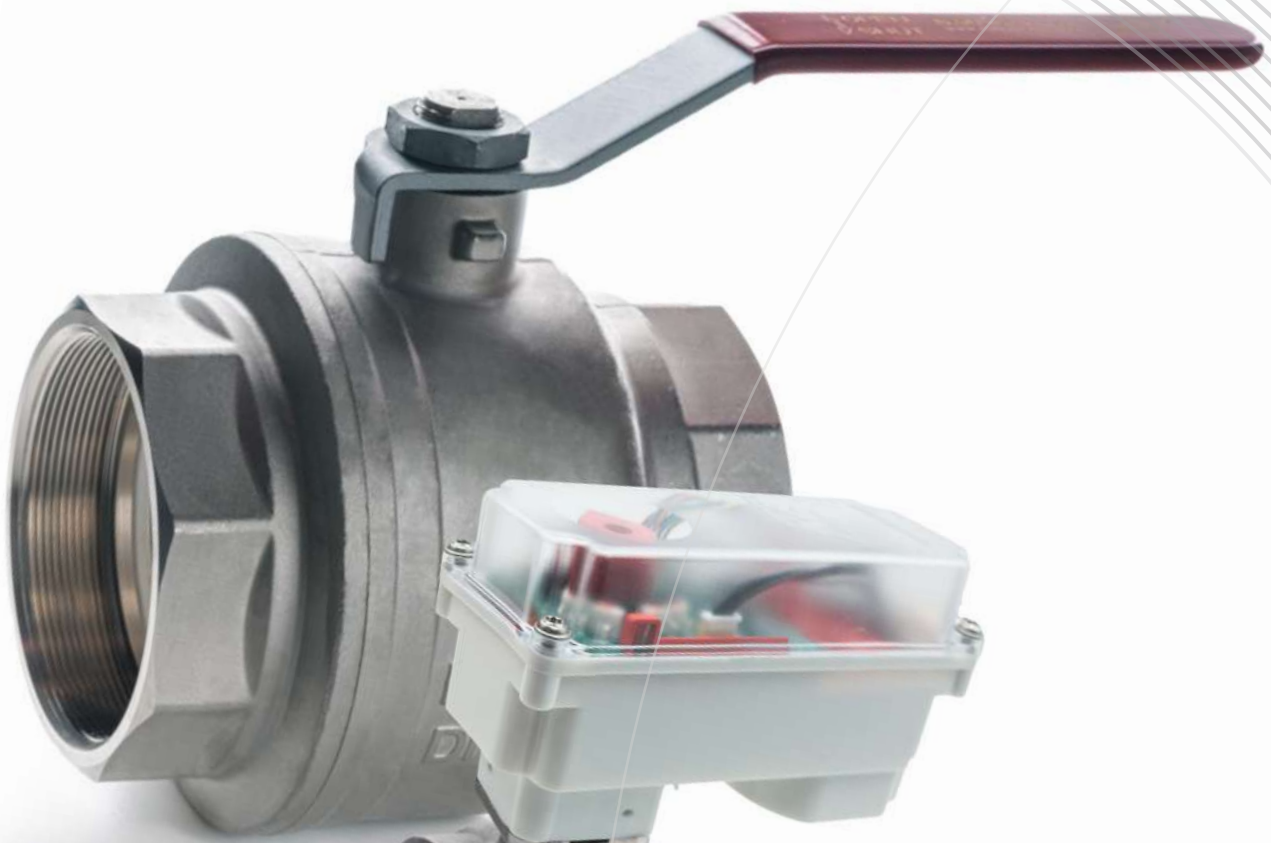

Application Catalog



ACTUATION



INDUSTRY



PNEUMATIC



GAS



FIREFIGHTING



DRINKING WATER



PLUMBING



ACCESSORIES



Ask for additional information on the whole range of **RuB** products and consult with your supplier for special applications.



ALL RIGHTS RESERVED | COPYRIGHT© Bonomi Industries Srl 2026

Bonomi Industries Srl endeavors to provide comprehensive information about the installation, maintenance and operation of its products. For more details or clarification, please contact us. **Bonomi Industries Srl** reserves the right to change or modify product design, construction, specifications, materials or the information herein without prior notice and without incurring any obligation to make such changes and modifications on products previously or subsequently sold. Content of this document is proprietary to **Bonomi Industries Srl** and it may not be copied in part or in whole without prior written authorization. Recommendations on application design and material selection are based on available technical data and are offered as suggestions only. Each user should make his/her own tests to determine the suitability for his/her own particular use. **Bonomi Industries Srl** gives no express or implied warranties concerning the form, fit, or function of a product in any application. **Bonomi Industries Srl** does not accept liability for errors or omissions. Any undated reference to a code or standard shall be interpreted as referring to the latest edition.

Bonomi Industries Srl, **RuB** and triangles, are all registered trademarks of **Bonomi Industries Srl**. Other logos or trademarks are property of respective owners.

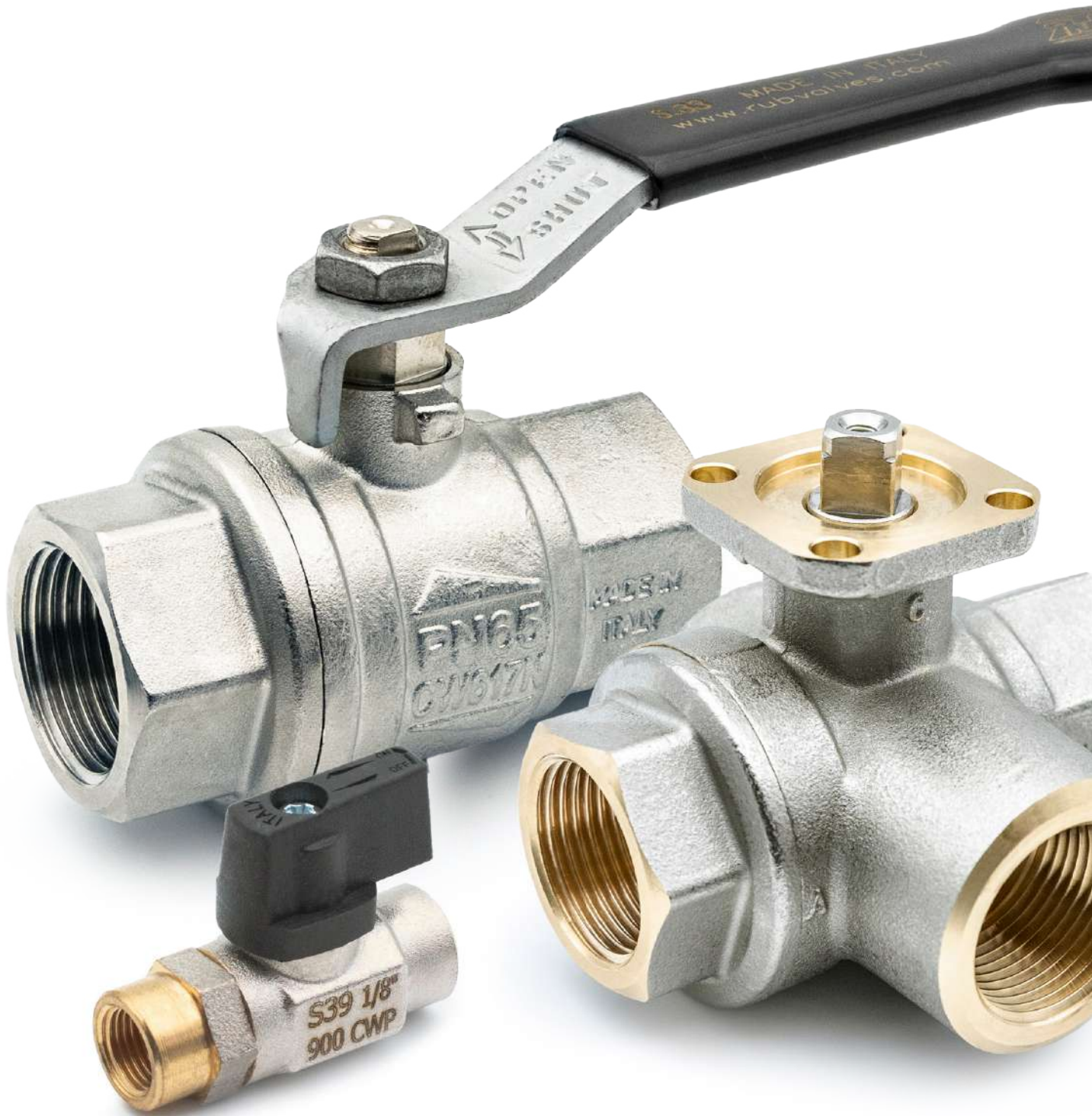



Via Padana Superiore, 29, 25080 Mazzano (BS), Italy
Tel.: +39 030 212441 - sales@rubvalves.com
www.rubvalves.com