

DRINKING WATER CATALOG



Started in 1954 by a young Silvio Bonomi, Bonomi Industries Srl led product and process innovations of the brass valve industry for over 70 years

Our founder's motto was "Quality and trust". This is the legacy we bring forward every day.







About us

Bonomi Industries Srl is an Italian manufacturer of high quality shut-off brass valves, actuators and custom-engineered solutions. Under the RuB brand, its products are globally trusted for their reliability and performance in a variety of applications.

Bonomi Industries Srl is part of Hadron group — a private holding company established in 2018 during the strategic reorganization of Rubinetterie Utensilerie Bonomi (RuB), which also led to the creation of Shedstone, a real estate company — Bonomi Industries Srl continues to grow and innovate. Started in 1954, with entrepreneurial roots tracing back to 1828, the company upholds the values and tradition of a family business while embracing a vision focused towards the future.

Growth at Bonomi Industries Srl is driven by continuous investments in product improvements, advanced machining, assembly, and logistics technologies, as well as expanded manufacturing capabilities, enhanced system interconnectivity, database analysis and strengthened engineering and R&D efforts. At the same time, sustainability — encompassing environmental, social, and governance topics — has always been part of the company's DNA and inspires meaningful actions.

For Bonomi Industries Srl, innovation and responsibility go hand in hand. This commitment shapes a journey aimed at safeguarding the environment, empowering people, and fostering resilient governance for a better tomorrow.



Bonomi Industries Srl turns words into actions for all stakeholders
Scan the QR code to discover our values



Companies

RuB valves and actuators are trusted worldwide, installed across five continents and proven in the most demanding applications.

Production takes place entirely at our headquarters, Bonomi Industries Srl, in Mazzano (Brescia), Italy. Finished products are then distributed globally from Italy and through our international branches. In North America, *RuB, Incorporated* operates from a modern 5.000 sqm (50,000 sqf) facility, handling both assembly and distribution. In Japan, *RuB kk* serves as a strategic presence in a peculiar market.

With a strong global presence, we provide proximity, reliability, and outstanding service to our customers. Our sales team builds lasting partnerships with distributors and OEMs by offering responsive support and technical expertise. Certified, high-quality products, combined with deep knowledge of local cultures and regulations, make Bonomi Industries Srl the trusted partner in fluid control solutions.



Bonomi Industries srl

MAZZANO, BS - ITALY
Manufacturing



RuB, Inc.

SHAKOPEE, MN - USA
Distribution



RuB KK

TOKYO - JAPAN
Distribution



RuB, Inc.
SHAKOPEE, MN - USA
Distribution



Bonomi Industries Srl
MAZZANO, BS - ITALY
Manufacturing



RuB KK
TOKYO - JAPAN
Distribution



Quality

Quality you can trust, proven through generations of experience.

From rigorous incoming goods inspections to double leak testing, 24-72 hour valve assessments, and visual inspections for top markets/applications, Bonomi Industries Srl ensures consistent reliability and precision in every product. Advanced traceability systems, calibrated instruments, and statistical software enhance quality control throughout the production process.

Our dedicated Quality Control team supports continuous monitoring and improvement, ensuring that each production batch meets exactly applicable standards. Paired with robust testing protocols and expert technical support, we deliver solutions designed to meet the most challenging applications.



Approved by Lloyd's Register Quality Assurance:

ISO 9001:2015 (Quality Management) since 1998.

ISO 14001:2018 (Environmental Management System) since 2021.

ISO 45001:2018 (Occupational Health & Safety) since 2021.



Environment: Air and water are filtered and recovered. Use of recycled environment-friendly packaging materials. Scrap is recycled.



Product Quality Assessment: recognized by certifying bodies in all major industrialized countries worldwide



Safety: compliance with the provisions of decree 81/2008 for the safety system, extensive staff training, and continuous monitoring



Customized products developed by the Engineering Center



In compliance with the **PED Directive** since 2002



Quality you can trust

See our quality process in action/Experience every step of our quality process





Sustainability

Sustainability has always been a necessity, not a choice. The adoption of sustainable practices at corporate level lays the foundation for creating virtuous cycles that inspire future generations.

Our commitment is stronger than ever, and we're proud to share with you here below figures that mark the tasks we focus on our actions, achievements, and the vision we have for the future. Localized production of electricity is now a reality and we have not been shy with our investments towards clean renewable energy.

Companies are finally waking up to producing their own electricity. Aside from covering the needs of our production manufacturing facility with through solar panels, we constantly reduce energy consumption by investing in smart technology and minimizing heavy material handling.

The diligence with which we strive to make our process and products less impactful on the environment is confirmed by the certifications awarded by international bodies, in particular ISO 14001:2018 and the "silver" medal in the EcoVadis sustainability assessment.

HOW WE WALK THE TALK.

100% of our brass ball valves prevent unnecessary waste – lifetime guaranteed

96% manufacturing scrap is reused

30% of energy comes from our own renewable sources

100% cooling waters are recovered and reused



Together, safeguarding our Planet
Learn more about our initiatives.







OEM

Every year, OEMs all over the world rely on RuB custom solutions to reduce leaks, equipment breakages and production downtime. We're heavily invested in OEM customizations with custom-made machinery for innovative products and solutions.

We have proven expertise in solving technical and operational challenges for leading boilers, heat pumps and burners manufacturers, LPG gas tank and system manufacturers, manufacturers of watering systems, fire protection, refrigeration, HVAC manufacturers, marine applications with shipbuilders, compressors, tanks, machine tools manufacturers, filtration, chemical, food processing and pharmaceutical companies.

We are intrigued to learn about your obstacles and bring your custom, top shelf solution to life.

PRIVATE LABEL

We strive to meet the needs of our customers in every way possible. And we do so not only through specifically designed, engineered and manufactured OEM products, but also by customizing standard RuB ball valves.

The possible branding options to choose from include:

- Changing the lever marking to the customer's trademark
- Packing with a custom label
- Customized handle colors and materials
- Customized valve fittings
- Dedicated valve body stamping
- Special marking on the valve body
- Custom installation instructions



OEM solutions, custom made for you

OEMs have a Partner to solve their challenges and develop new products





Certifications

We are proud to offer 100% made-in-Italy shut-off brass valves, actuators, and OEM-engineered products, all manufactured in our ISO 9001:2015 certified headquarters in Brescia, Italy. Since adopting this quality management system in 1992 under Lloyd's Register, we have continuously improved product reliability, performance and traceability.

Our certifications, granted by leading global laboratories and agencies, demonstrate compliance with the highest standards for major applications and markets. Supported by rigorous testing and state of art technology, our products meet the demanding requirements of top manufacturers and distributors worldwide.

PRODUCT TYPE APPROVALS

	Deutsche Vereinigung des Gas und Wasserfaches e.V. Technisch-wissenschaftlicher Verein			General Directorate of Civil Defence	
	Deutsche Vereinigung des Gas und Wasserfaches			The Australian Gas Association	
	Deutsche Vereinigung des Gas und Wasserfaches Hygiene			OSHA Compliant	
	Schweizerischer Verein des Gas und Wasserfaches			Factory Mutual Research Corporation	
	Attestation de Conformité Sanitaire			Underwriter Laboratories Inc.	
	ARGB-KVBG			CRN-TSSA	
	Water Regulations Advisory Scheme			CSA International for Drinking Water to NSF/ANSI 61- NSF/ANSI 372	
	British Standards Institution			CSA - Canadian Standards Association	
	Kiwa KUKreg4			KSFD -Kuwait Fire Service Directorate	
	Ri.se. / Boverket			LIA - L.P Gas Instruments Inspections Association	
	Kiwa - Swedcert				

COMPLIANCES

	ROHS			PED 2014/68/UE by ICIM (0425)	PED
	Reach declaration	Reach		Декларация соответствия	EAC



We developed and constantly innovate strict protocols and processes
Discover all the certifications and awards received from international bodies



PATENTED
NO. 1421306

▲ OPEN
▼ SHUT

RuB valve features

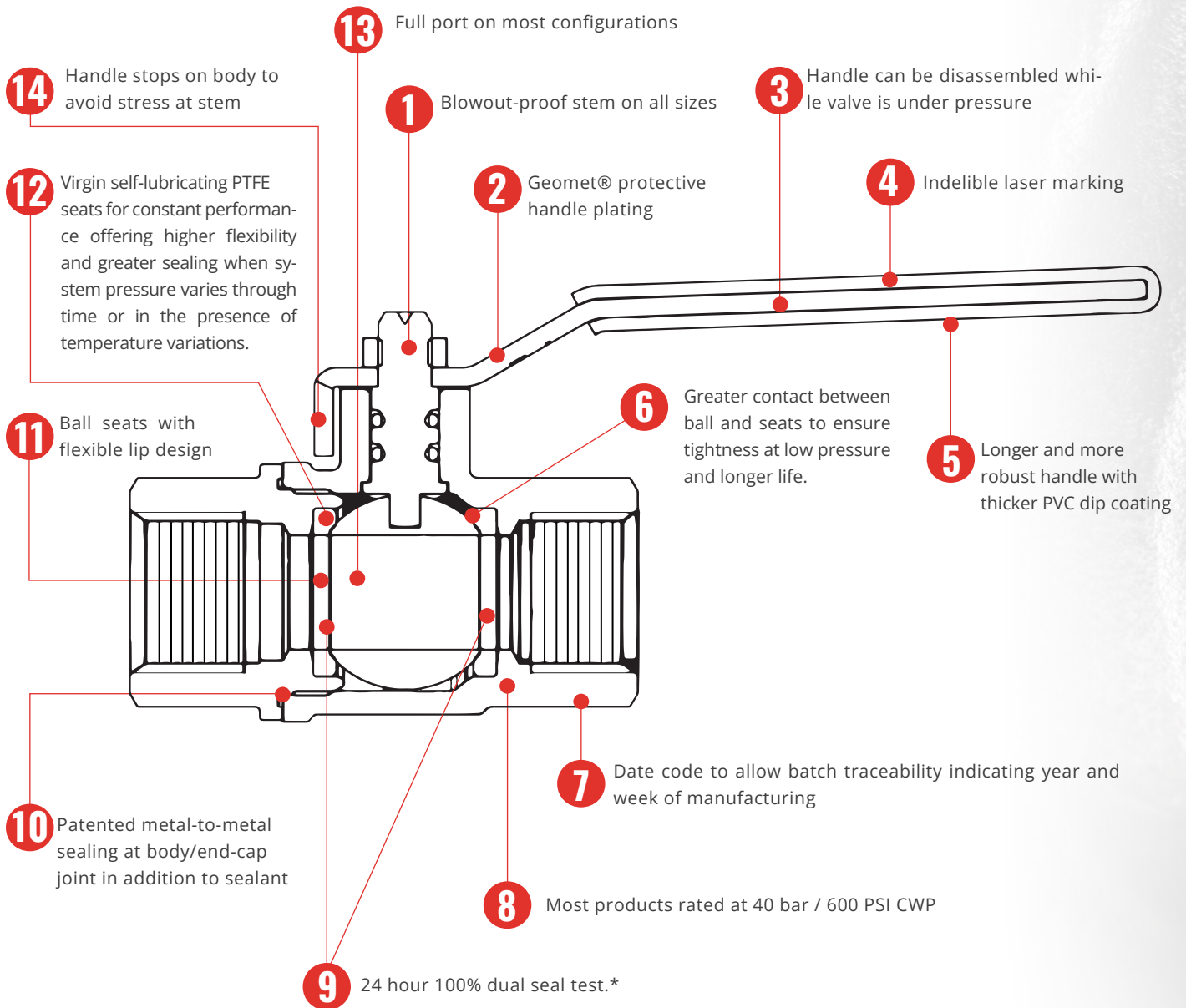

RuB seal test

Valve in half open position is pressurized at 6 bar (87 psig), then closed, trapping compressed air in between ball seats and stem sealing. After adequate preset time, based upon valve size, any leaks are verified using extremely accurate electronic sensors and any defective valve is automatically rejected; all valves passing this initial seal test are filled with compressed air again and remain closed and under pressure for minimum 24 hours; after 24 hours, the valves go back again under the same accurate a new set of electronic pressure sensors and any leaking valve is automatically rejected.

* Certain products are not suitable for double seal test



Our solutions come with an added benefit: maximizing your revenue
Scan the QR code to discover our products



DRINKING WATER

Water is life, and it deserves the utmost respect through the highest safety and hygiene standards. With decades of expertise, we manufacture ball valves using specialized alloys that meet regulations worldwide. Whether it's DZR brass CW602N, Lead-Free CW510L, CW511L, or UBA-approved CW617N, RuB valves are designed to meet your specific drinking water needs.





s.20 DZR 1/4" - 2" ISO 228, dezincification-resistant	Page 20
s.20 DZR M/F 3/8" - 1 1/4" ISO 228, dezincification-resistant	Page 22
s.21 DZR 12 - 54 mm solder ends, for insulation, dezincification-resistant	Page 24
s.24 DZR press ends 15 - 54 mm, dezincification-resistant	Page 26
s.24 DZR 1/2" - 4" EN 10226-1, dezincification-resistant	Page 28
s.24 DZR 1/2" - 4" EN 10226-1, dezincification-resistant, stainless steel handle	Page 30
s.26 DZR 3/8" - 2" ISO 228, for insulation, dezincification-resistant	Page 32
s.28 DZR 12 - 54 mm compression ends, dezincification-resistant	Page 34
s.30 DZR 12 - 54 mm compression ends, for insulation, dezincification-resistant	Page 36
s.84 W 1/4" - 2", EN 10226-1	Page 38
s.84 W M/F 1/4" - 2", EN 10226-1	Page 40
s.84W M/F 3/4" for flat gasket	Page 42
s.468LF DZR 22 mm compression ends, ISO 5211, Lead-Free, dezincification-resistant	Page 44
Puri-T 292 NPT 1/4" - 2" Lead Free	Page 46
Puri-T 242 1/2" - 2" Lead Free, solder ends	Page 48
Puri-T 264 NPT 1/2" - 1 1/2" Lead Free, ISO 5211	Page 50



s.20 DZR

Female/Female
1/4" - 2"
ISO 228, dezincification-resistant

Several governmental authorities recommend use of special alloys for valves handling water in areas where there is a problem of dezincification.

RuB DZR valves are designed to meet such requirements.

Through the use of new technology these valves retain the reliability and competitiveness of brass, but are comparable to bronze in corrosion resistance.

Be kind with yourself, make sure the valve that brings you pure fresh water is an **RuB** DZR valve.



QUALITY

- 24h 100% seal test guaranteed
- Dual sealing system allows valve to be operated in either direction making installation easier
- No metal-to-metal moving parts
- No maintenance ever required
- Handle clearly shows ball position
- Silicone-free lubricant on all seals
- Chrome plated DZR brass ball for longer life
- Handle stops on body to avoid stress at stem

BODY

- Hot forged sand blasted DZR unplated body and cap sealed with Loctite® or equivalent thread sealant
- Dezincification resistant ADZ-T and ADZ-P brass approved to SBN-PFS 1983:2 and NR-BFS 1988:18 specifications

STEM

- Maintenance-free, double FPM O-rings at the stem for maximum safety
- Blowout-proof unplated DZR brass stem

SEALING

- Pure PTFE self-lubricating seats with flexible-lip design

THREADS

- ISO 228 parallel female by female threads

FLOW

- Full port to DIN 3357 for maximum flow

HANDLE

- Geomet® carbon steel handle with thick PVC dip coating. Handle coating offers both thermal and electrical protection
- Handle removable with valve in service
- **WARNING:** do not exceed reasonable temperature and/or electrical load

WORKING PRESSURE & TEMPERATURE

- 30 bar (450 PSI) non-shock cold working pressure
- -40°C to +170°C (-40°F to +350°F)
- **WARNING:** freezing of the fluid in the installation may severely damage the valve

UPON REQUEST

- Stainless steel ball (1.4401 / AISI 316)
- Glass filled PTFE seals
- Custom design
- Male by female threads

PED DIRECTIVE

- According to 2014/68/UE module A: it cannot be used with dangerous gases in sizes larger than 25mm

APPROVED BY OR IN COMPLIANCE WITH

- RoHS Compliant (EU)
- KIWA Regulation 4 a.k.a. KUKreg4 (United Kingdom)
- EAC – Declaration of conformity (Russia, Kazakhstan, Belarus)
- Water Regulations Advisory Scheme (United Kingdom)

NOTE: approvals apply to specific configurations/sizes only.

OPTIONS

- Oval lockable handle **1**
- Patented locking device **2**
- Stainless steel handle (1.4016 / AISI 430) **3**
- **RuB** memory stop designed to be installed with our stubby handle
- T-handle **4**
- CW617N brass body and components **5**
- Brass stem extension **5**
- Stubby handle



s.20 DZR XGES20 - 6012

Each user should perform his own tests to find out the suitability for his particular application. BONOMI INDUSTRIES makes no warranty, express or implied, as to the shape, fit or function of a product for any application. Contact us or consult with your supplier for additional information on the suitability of the BONOMI INDUSTRIES products with your specific field of use.



Part description	Q.ty	Material
1 Unplated body	1	CW602N
2 Ball seat	2	PTFE
3 Chrome plated ball	1	CW602N
4 Unplated end-cap	1	CW602N
5 Unplated stem O-ring design	1	CW602N
6 Geomet® nut	1	C4C (EN10263-2)
7 O-Ring	2	FPM
8 White PVC coated Geomet® steel handle	1	DD11 (EN10111)

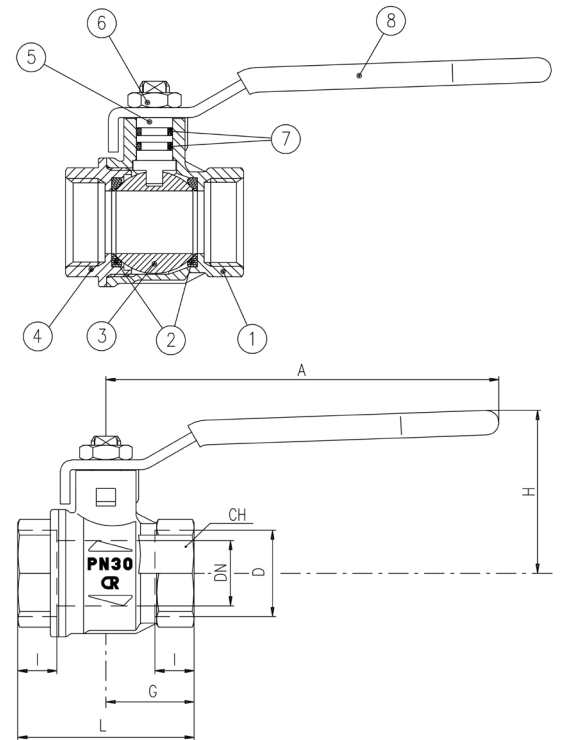

1 1/4"-2" hollow ball

Compliant to CE 2014/68/UE product
Equipment category I Module A

Code	S20B00	S20C00	S20D00	S20E00	S20F00	S20G00	S20H00	S20I00
D (inch)	1/4"	3/8"	1/2"	3/4"	1"	1 1/4"	1 1/2"	2"
DN (mm)	8	10	15	20	25	32	40	50
I (mm)	9	9	11	12	14	15	17	19
L (mm)	39	39	50	54	67	77	90	106
G (mm)	19.5	19.5	25	27	33.5	38.5	45	53
A (mm)	100	100	100	120	120	158	158	158
H (mm)	39	39	43	50	54	73	79	86
CH (mm)	17	20	25	31	38	48	54	66
Kv (m ³ /h)	3.9	8.2	28	42	70	80	125	179

DN shows the nominal flow diameter. Actual flow diameter complies with full port DIN 3357 part 4.

PRESSURE-TEMPERATURE CHART

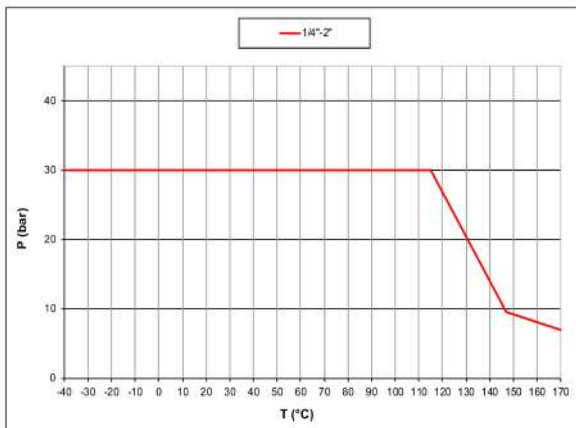

PRESSURE DROP CHART

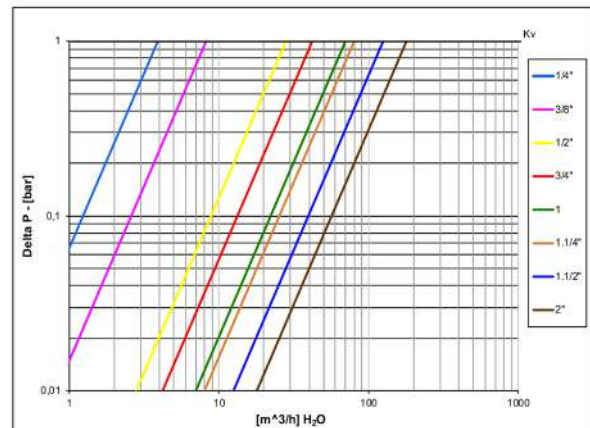



s.20 DZR M/F

Male/Female
3/8" - 1 1/4"
ISO 228, dezincification-resistant

Several governmental authorities recommend use of special alloys for valves handling water in areas where there is a problem of dezincification. **RuB** DZR valves are designed to meet such requirements.

Through the use of new technology these valves retain the reliability and competitiveness of brass, but are comparable to bronze in corrosion resistance.

Be kind with yourself, make sure the valve that brings you pure fresh water is an **RuB** DZR valve.



QUALITY

- 24h 100% seal test guaranteed
- Dual sealing system allows valve to be operated in either direction making installation easier
- No metal-to-metal moving parts
- No maintenance ever required
- Handle clearly shows ball position
- Silicone-free lubricant on all seals
- Chrome plated DZR brass ball for longer life
- Handle stops on body to avoid stress at stem

BODY

- Hot forged sand blasted DZR unplated body and cap sealed with Loctite® or equivalent thread sealant
- Dezincification resistant ADZ-T and ADZ-P brass approved to SBN-PFS 1983:2 and NR-BFS 1988:18 specifications

STEM

- Maintenance-free, double FPM O-rings at the stem for maximum safety
- Blowout-proof unplated DZR brass stem

SEALING

- Pure PTFE self-lubricating seats with flexible-lip design

THREADS

- ISO 228 parallel male by female threads

FLOW

- Full port to DIN 3357 for maximum flow

HANDLE

- Geomet® carbon steel handle with thick PVC dip coating. Handle coating offers both thermal and electrical protection
- Handle removable with valve in service
- **WARNING:** do not exceed reasonable temperature and/or electrical load

WORKING PRESSURE & TEMPERATURE

- 30 bar (450 PSI) non-shock cold working pressure
- -40°C to +170°C (-40°F to +350°F)
- **WARNING:** freezing of the fluid in the installation may severely damage the valve

UPON REQUEST

- Stainless steel ball (1.4401 / AISI 316)
- Glass filled PTFE seals
- Custom design

PED DIRECTIVE

- According to 2014/68/UE module A: it cannot be used with dangerous gases in sizes larger than 25mm

APPROVED BY OR IN COMPLIANCE WITH

- RoHS Compliant (EU)
- EAC – Declaration of conformity (Russia, Kazakhstan, Belarus)
- KIWA Regulation 4 a.k.a. KUKreg4 (United Kingdom)
- Water Regulations Advisory Scheme (United Kingdom)

NOTE: approvals apply to specific configurations/sizes only.

OPTIONS

- Oval lockable handle ①
- Patented locking device ②
- Stainless steel handle (1.4016 / AISI 430) ③
- **RuB** memory stop designed to be installed with our stubby handle
- T-handle ④
- CW617N brass body and components ⑤
- Brass stem extension ⑤
- Stubby handle



s.20 DZR MF XGES20M - 6012

Each user should perform his own tests to find out the suitability for his particular application. BONOMI INDUSTRIES makes no warranty, express or implied, as to the shape, fit or function of a product for any application. Contact us or consult with your supplier for additional information on the suitability of the BONOMI INDUSTRIES products with your specific field of use.



Part description		Q.ty	Material
1	Unplated body	1	CW602N
2	Ball seat	2	PTFE
3	Chrome plated ball	1	CW602N
4	Unplated end-cap	1	CW602N
5	Unplated stem O-ring design	1	CW602N
6	Geomet® nut	1	C4C (EN10263-2)
7	O-Ring	2	FPM
8	White PVC coated Geomet® steel handle	1	DD11 (EN10111)

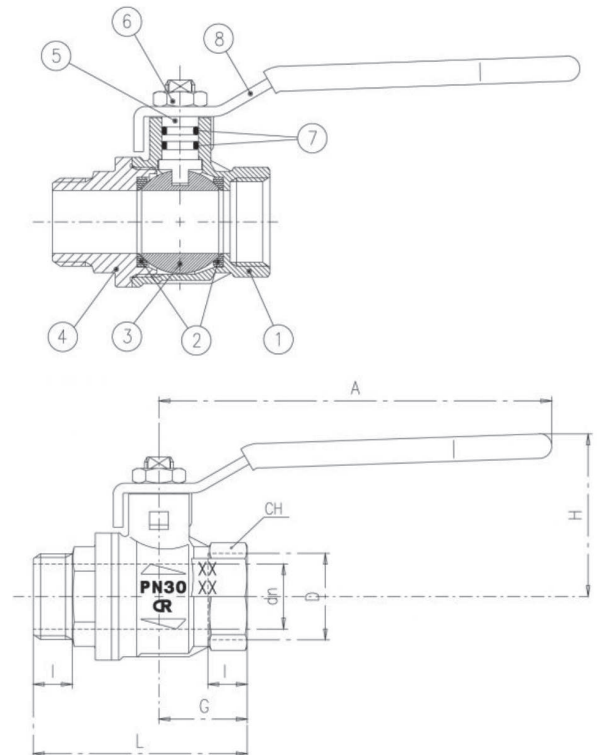

Compliant to CE
2014/68/UE product
Equipment category I
Module A

Code	S20C20	S20D20	S20E20	S20F00	S20G00
D (inch)	3/8"	1/2"	3/4"	1"	1 1/4"
DN (mm)	10	15	20	25	32
I (mm)	9	11	12	14	15
L (mm)	49	60	65.5	77.5	89
G (mm)	19.5	25	27	33.5	38.5
A (mm)	82	100	120	120	158
H (mm)	38	43	50	54	73
CH (mm)	20	25	31	38	48
Kv (m³/h)	8.2	28	42	70	80

DN shows the nominal flow diameter. Actual flow diameter complies with full port DIN 3357 part 4

PRESSURE-TEMPERATURE CHART

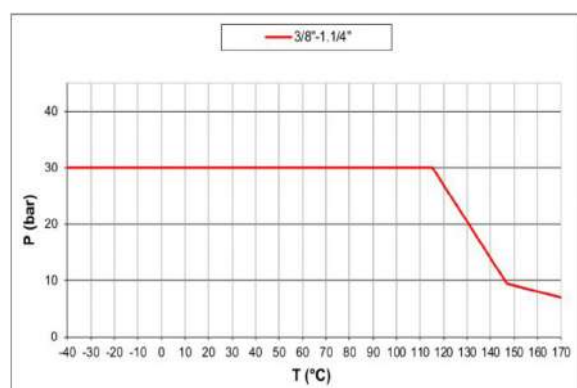

PRESSURE DROP CHART

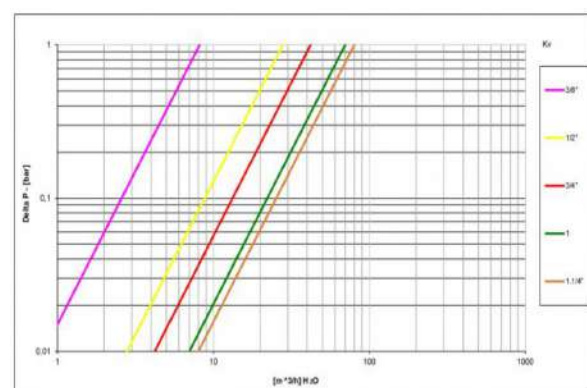



s.21 DZR

**12 - 54 mm solder ends
for insulation
dezincification-resistant**

Several governmental authorities recommend use of special alloys for valves handling water in areas where there is a problem of dezincification.

RuB DZR valves are designed to meet such requirements. Through the use of new technology these valves retain the reliability and competitiveness of brass, but are comparable to bronze in corrosion resistance. Be kind with yourself, make sure the valve that brings you pure fresh water is an **RuB** DZR valve.



QUALITY

- 24h 100% seal test guaranteed
- Dual sealing system allows valve to be operated in either direction making installation easier
- No metal-to-metal moving parts
- No maintenance ever required
- Handle clearly shows ball position
- Silicone-free lubricant on all seals
- Chrome plated DZR brass ball for longer life
- Handle stops on body to avoid stress at stem

BODY

- Hot forged sand blasted DZR unplated body and cap sealed with Loctite® or equivalent thread sealant
- Dezincification resistant ADZ-T and ADZ-P brass approved to SBN- PFS 1983:2 and NR- BFS 1988:18 specifications

STEM

- Maintenance-free, double FPM O-rings at the stem for maximum safety

SEALING

- Pure PTFE self-lubricating seats with flexible-lip design

CONNECTIONS

- Solder ends to NS1759 and ISO 2016

FLOW

- Full port to DIN 3357 for maximum flow

HANDLE

- Geomet® carbon steel handle with thick PVC dip coating. Handle coating offers both thermal and electrical protection
- Handle removable with valve in service
- **WARNING:** do not exceed reasonable temperature and/or electrical load

WORKING PRESSURE & TEMPERATURE

- 16 bar (230 PSI) non-shock cold working pressure
- -40°C to +170°C (-40°F to +350°F)
- Applicable to valve, not to solder joints
- **WARNING:** freezing of the fluid in the installation may severely damage the valve

UPON REQUEST

- Stainless steel ball (1.4401 / AISI 316)
- Glass filled PTFE seals
- Custom design

PED DIRECTIVE

- The product described in this document meets the requirements of PED Directive 2014/68/UE and according to art.4 par.3, it does not require CE marking; it cannot be used with dangerous gases in sizes larger than 25mm

APPROVED BY OR IN COMPLIANCE WITH

- RoHS Compliant (EU)
- EAC – Declaration of conformity (Russia, Kazakhstan, Belarus)
- Kiwa-Swedcert (Sweden)
- Ri.se. / Boverket (Sweden)

NOTE: approvals apply to specific configurations/sizes only.

OPTIONS

- Oval lockable handle **1**
- Patented locking device **2**
- **RuB** memory stop designed to be installed with our stubby handle
- Stainless steel handle (1.4016 / AISI 430) **3**
- Stubby handle
- T-handle **4**



s.21 DZR XCES21 - 5813

Each user should perform his own tests to find out the suitability for his particular application. BONOMI INDUSTRIES makes no warranty, express or implied, as to the shape, fit or function of a product for any application. Contact us or consult with your supplier for additional information on the suitability of the BONOMI INDUSTRIES products with your specific field of use.



DRINKING WATER

	Part description	Q.ty	Material
1	Unplated body	1	CW602N
2	Ball seat	2	PTFE
3	Chrome plated ball	1	CW602N
4	Unplated end-cap	1	CW602N
5	Unplated nut	2	CW617N
6	Unplated solder end hose	2	CC491K
7	Unplated extended stem O-ring design	1	CW602N
8	O-Ring	2	FPM
9	Unplated nut	1	CW617N
10	Geomet® nut	1	C4C (EN10263-2)
11	White PVC coated Geomet® steel handle	1	DD11 (EN10111)

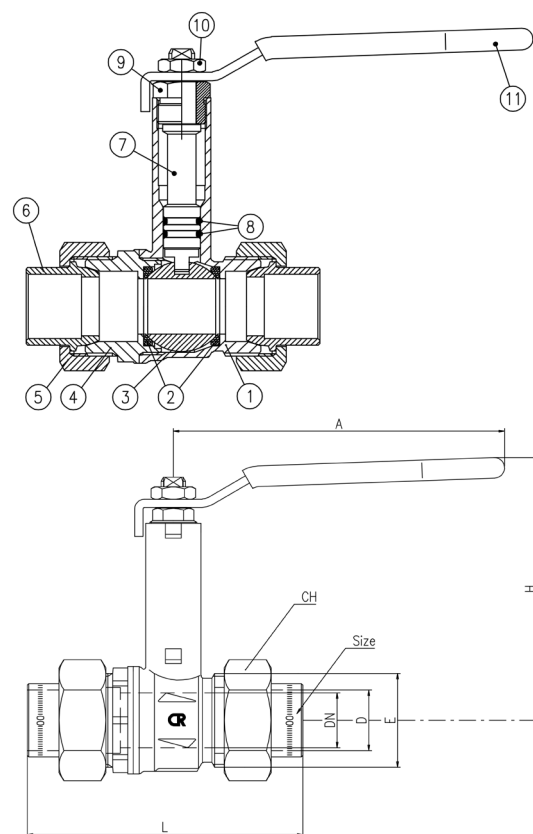

Hollow ball for D 35-42-54

Code	S21C12W	S21D15W	S21E18W	S21E22W	S21F28W	S21G35W	S21H42W	S21I54W
D (mm)	12	15	18	22	28	35	42	54
E (mm)	M22x1.5	M26x1.5	M34x1.5	M34x1.5	M40x2	M50x2	M55x2	M70x2
DN (mm)	10	15R	16R	20R	25R	32R	40R	50R
L (mm)	80	90	100	100	115	129	143	161
A (mm)	100	100	120	120	120	158	158	158
H (mm)	85	88	95	95	99	124	130	137
CH (mm)	26	30	38	38	46	55	62	78
Kv (m ³ /h)	9.6	28	42	42	70	80	125	179

DN shows the nominal flow diameter.

PRESSURE-TEMPERATURE CHART

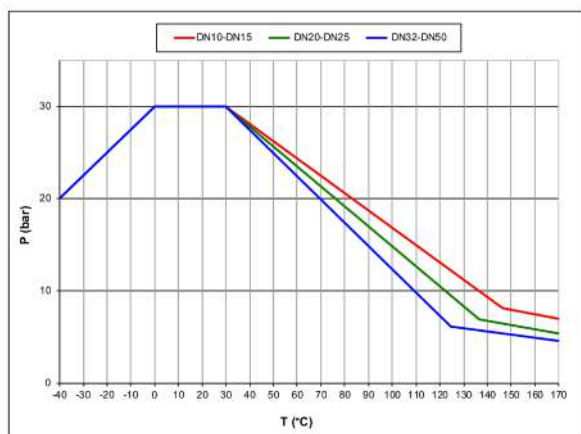

The given data of the pressure-temperature chart refer to the valve body

PRESSURE DROP CHART

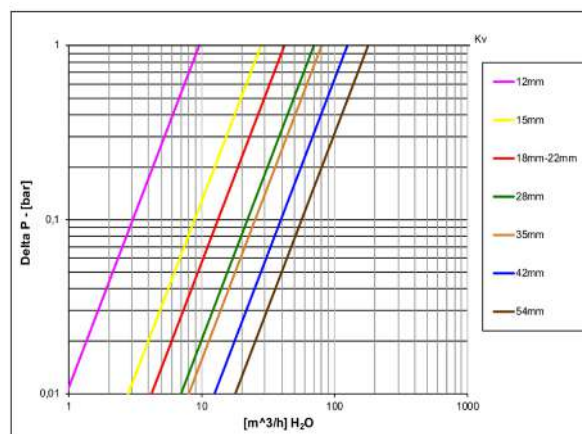



s.24 DZR press ends

**15 - 54 mm
dezincification-resistant**

Time is of essence and valve technology has progressed to save time and ease on-site installation.

RuB s.24 DZR with press ends combines first class features of our s.24 which have been optimized through years of field experience and innovative press fittings which can be pressed with all pressing jaws and tools provided for metal connections type M and V.

Be kind with yourself, make sure the valve that brings you pure fresh water is an **RuB** DZR ball valve. Press-end couplings are made of bronze, a material well known for its suitability to the press operation. Each coupling assembly is seal tested at the plant.



QUALITY

- 100% seal test guaranteed
- Dual sealing system allows valve to be operated in either direction making installation easier
- No metal-to-metal moving parts
- No maintenance ever required
- Handle clearly shows ball position
- Silicone-free lubricant on all seals
- Handle stops on body to avoid stress at stem
- Chrome plated DZR brass ball for longer life

BODY

- Hot forged sand blasted DZR unplated body and cap sealed with Loctite® or equivalent threads sealant
- Dezincification resistant ADZ-T and ADZ-P brass approved to SBN-PFS 1983:2 and NR-BFS 1988:18 specifications

STEM

- Maintenance-free, double FPM O-rings at the stem for maximum safety
- Blowout-proof unplated DZR brass stem

SEALING

- Pure PTFE self-lubricating seats with flexible-lip design

CONNECTIONS

- Press ends connections to EN 1254-4 approved by DVGW

FLOW

- Full port to DIN 3357 for maximum flow

HANDLE

- Geomet® carbon steel handle with thick PVC dip coating. Handle coating offers both thermal and electrical protection
- Handle removable with valve in service
- **WARNING:** do not exceed reasonable temperature and/or electrical load

WORKING PRESSURE & TEMPERATURE

- 16 bar (230 PSI) non-shock cold working pressure
- -20°C to +120°C (-4°F to +250°F)
- **WARNING:** freezing of the fluid in the installation may severely damage the valve

UPON REQUEST

- Stainless steel ball (1.4401 / AISI 316)
- Glass filled PTFE seals
- Custom Design

PED DIRECTIVE

- The product described in this document meets the requirements of PED Directive 2014/68/UE and according to art.4 par.3, it does not require CE marking; it cannot be used with dangerous gases in sizes larger than 25mm

APPROVED BY OR IN COMPLIANCE WITH

- RoHS Compliant (EU)
- EAC – Declaration of conformity (Russia, Kazakhstan, Belarus)

NOTE: approvals apply to specific configurations/sizes only.

OPTIONS

- Oval lockable handle **1**
- Patented locking device **2**
- Stainless steel handle (1.4016 / AISI 430) **3**
- **RuB** memory stop designed to be installed with our stubby handle
- T-handle **4**
- CW617N brass body and components **5**
- Brass stem extension **5**
- Stubby handle



s.24 DZR PRESS ENDS XCES24C - 5813

Each user should perform his own tests to find out the suitability for his particular application. BONOMI INDUSTRIES makes no warranty, express or implied, as to the shape, fit or function of a product for any application. Contact us or consult with your supplier for additional information on the suitability of the BONOMI INDUSTRIES products with your specific field of use.



Part description		Q.ty	Material
1	Unplated body	1	CW602N
2	Ball seat	2	PTFE
3	Chrome plated ball	1	CW602N
4	Unplated end-cap	1	CW602N
5	Unplated stem O-ring design	1	CW602N
6	Geomet® nut	1	CB4FF (EN10263-2)
7	O-Ring	2	FPM
8	White PVC coated Geomet® steel handle	1	DD11 (EN10111)
9	O-Ring	2	EPDM
10	Unplated press end connection	2	CW724R

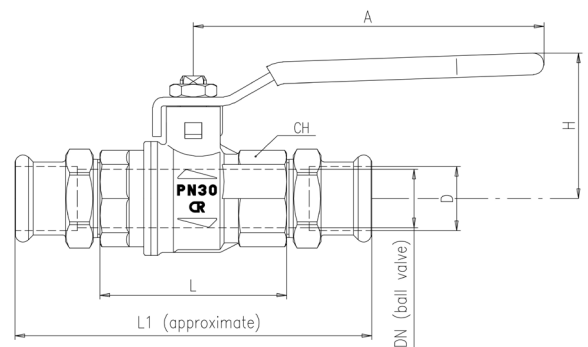
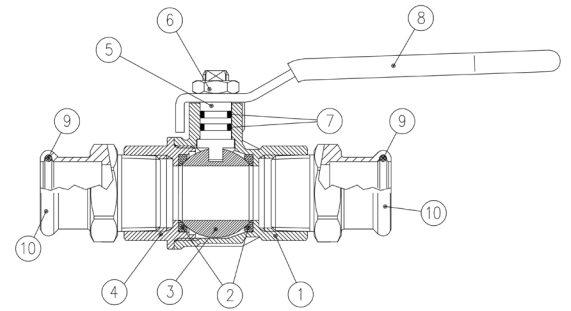

35-54 mm hollow ball

Code	S24DC15	S24EC22	S24FC28	S24GC35	S24HC42	S24IC54
D (mm)	15	22	28	35	42	54
DN (mm)	15	20	25	32	40	50
L (mm)	59	64	81	93	102	121
L1 (mm)	118	123	146	164	187	220
A (mm)	100	120	120	158	158	158
H (mm)	43	50	54	73	79	86
CH (mm)	25	31	40	49	54	68,5
Kv (m3/h)	28	42	70	80	125	179

DN shows the nominal flow diameter. Actual flow diameter complies with full port DIN 3357 part 4.

PRESSURE-TEMPERATURE CHART

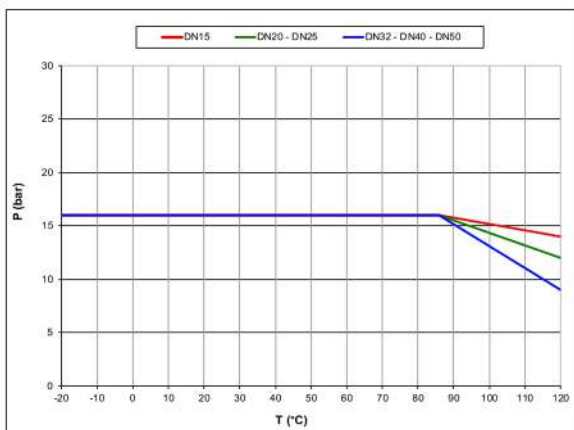

PRESSURE DROP CHART

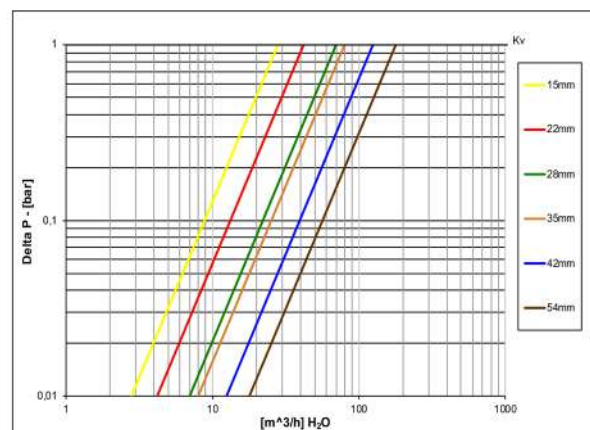



s.24 DZR

Female/Female
1/2" - 4"
EN 10226-1, dezincification-resistant

Several governmental authorities recommend use of special alloys for valves handling water in areas where there is a problem of dezincification.

RuB DZR valves are designed to meet such requirements.

Through the use of new technology these valves retain the reliability and competitiveness of brass, but are comparable to bronze in corrosion resistance.

Be kind with yourself, make sure the valve that brings you pure fresh water is an **RuB** DZR valve.



QUALITY

- 24h 100% seal test guaranteed
- Dual sealing system allows valve to be operated in either direction making installation easier
- No metal-to-metal moving parts
- No maintenance ever required
- Handle clearly shows ball position
- Silicone-free lubricant on all seals
- Chrome plated DZR brass ball for longer life
- Handle stops on body to avoid stress at stem

BODY

- Hot forged sand blasted DZR unplated body and cap sealed with Loctite® or equivalent thread sealant
- Dezincification resistant ADZ-T and ADZ-P brass approved to SBN-PFS 1983:2 and NR-BFS 1988:18 specifications

STEM

- Maintenance-free, double FPM O-rings at the stem for maximum safety
- Blowout-proof unplated DZR brass stem

SEALING

- Pure PTFE self-lubricating seats with flexible-lip design

THREADS

- EN 10226-1, ISO 228 parallel female by female threads

FLOW

- Full port to DIN 3357 for maximum flow

HANDLE

- Geomet® carbon steel handle with thick PVC dip coating. Handle coating offers both thermal and electrical protection
- Handle removable with valve in service
- **WARNING:** do not exceed reasonable temperature and/or electrical load

WORKING PRESSURE & TEMPERATURE

- 30 bar (450 PSI) non-shock cold working pressure
- -40°C to +170°C (-40°F to +350°F)
- **WARNING:** freezing of the fluid in the installation may severely damage the valve

UPON REQUEST

- Crimp/press end connections
- Stainless steel ball (1.4401 / AISI 316)
- Glass filled PTFE seals
- Custom design

PED DIRECTIVE

- According to 2014/68/UE module A: it cannot be used with dangerous gases in sizes larger than 25mm

APPROVED BY OR IN COMPLIANCE WITH

- RoHS Compliant (EU)
- KIWA Regulation 4 a.k.a. KUKreg4 (United Kingdom)
- EAC – Declaration of conformity (Russia, Kazakhstan, Belarus)
- Water Regulations Advisory Scheme (United Kingdom)

- **NOTE:** approvals apply to specific configurations/sizes only.

OPTIONS

- Oval lockable handle up to 2", round over 2" **1**
- Patented locking device **2**
- Stainless steel handle (1.4016 / AISI 430) **3**
- **RuB** memory stop designed to be installed with our stubby handle
- T-handle **4**
- CW617N brass body and components **5**
- Brass stem extension **5**
- Stubby handle up to 2"



s.24 DZR XGES24 - 6012

Each user should perform his own tests to find out the suitability for his particular application. BONOMI INDUSTRIES makes no warranty, express or implied, as to the shape, fit or function of a product for any application. Contact us or consult with your supplier for additional information on the suitability of the BONOMI INDUSTRIES products with your specific field of use.



DRINKING WATER

Part description		Q.ty	Material
1	Unplated body	1	CW602N
2	Ball seat	2	PTFE
3	Chrome plated ball	1	CW602N
4	Unplated end-cap	1	CW602N
5	Unplated stem O-ring design	1	CW602N
6	Geomet® nut	1	C4C (EN10263-2)
7	O-Ring	2	FPM
8	White PVC coated Geomet® steel handle	1	DD11 (EN10111)

1 1/4"-2" hollow ball

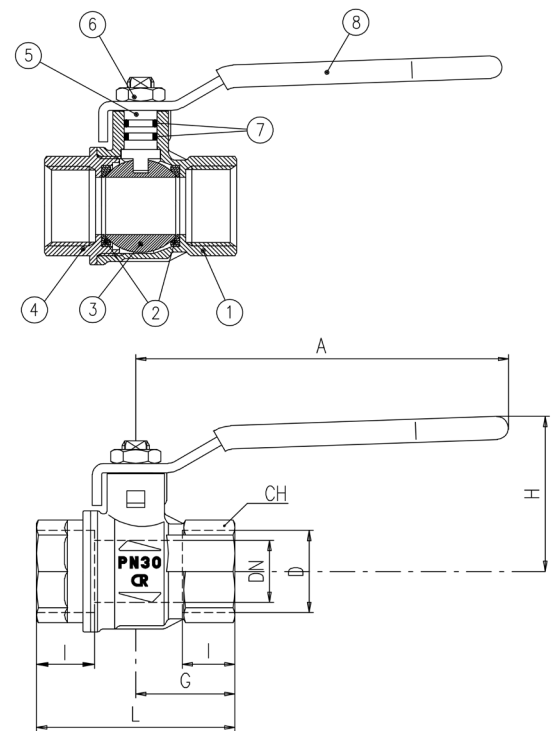

Compliant to CE 2014/68/UE product Equipment category I Module A

Code	S24D00	S24E00	S24F00	S24G00	S24H00	S24I00	S24L00	S24M00	S24N00
D (inch)	1/2"	3/4"	1"	1 1/4"	1 1/2"	2"	2 1/2"	3"	4"
DN (mm)	15	20	25	32	40	50	65	80	100
I (mm)	15.5	17	21	23	23	26.5	32	35	41.5
L (mm)	59	64	81	93	102	121	156	177	216
G (mm)	29.5	32	40.5	46.5	51	60.5	78	88.5	108
A (mm)	100	120	120	158	158	158	255	255	255
H (mm)	43	50	54	73	79	86	132	140	154
CH (mm)	25	31	40	49	54	68.5	85	99	125
Kv (m ³ /h)	28	42	70	80	125	179	516	776	1130

DN shows the nominal flow diameter. Actual flow diameter complies with full port DIN 3357 part 4. Stem configuration of valves over 2" is slightly different. Ball valves are marked CE on handle from 1 1/4" to 2", on body over 2" as follows: CE XXCODEXX Cat. I-A

PRESSURE-TEMPERATURE CHART

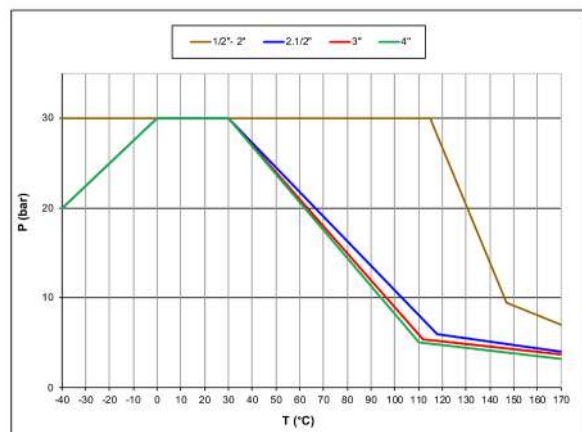

PRESSURE DROP CHART

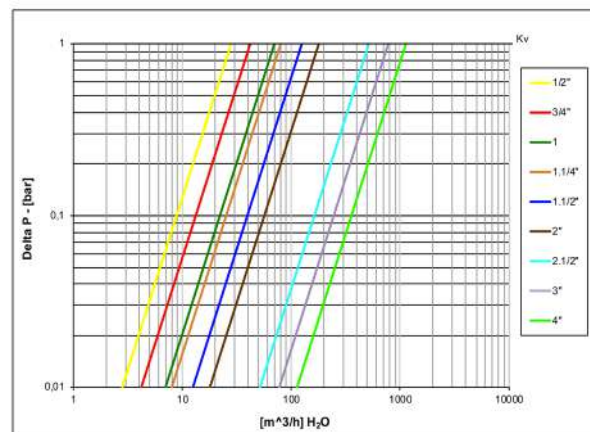



s.24 DZR

Female/Female
1/2" - 4"

EN 10226-1, dezincification-resistant, stainless steel handle



Several governmental authorities recommend use of special alloys for valves handling water in areas where there is a problem of dezincification.

RuB DZR valves are designed to meet such requirements.

Through the use of new technology these valves retain the reliability and competitiveness of brass, but are comparable to bronze in corrosion resistance.

Be kind with yourself, make sure the valve that brings you pure fresh water is an **RuB** DZR valve.



QUALITY

- 24h 100% seal test guaranteed
- Dual sealing system allows valve to be operated in either direction making installation easier
- No metal-to-metal moving parts
- No maintenance ever required
- Handle clearly shows ball position
- Silicone-free lubricant on all seals
- Chrome plated DZR brass ball for longer life
- Handle stops on body to avoid stress at stem

BODY

- Hot forged sand blasted DZR unplated body and cap sealed with Loctite® or equivalent thread sealant
- Dezincification resistant ADZ-T and ADZ-P brass approved to SBN-PFS 1983:2 and NR-BFS 1988:18 specifications

STEM

- Maintenance-free, double FPM O-rings at the stem for maximum safety
- Blowout-proof unplated DZR brass stem

SEALING

- Pure PTFE self-lubricating seats with flexible-lip design

THREADS

- EN 10226-1, ISO 228 parallel female by female threads

FLOW

- Full port to DIN 3357 for maximum flow

HANDLE

- Stainless steel handle with thick PVC dip coating. Handle coating offers both thermal and electrical protection
- Handle removable with valve in service
- **WARNING:** do not exceed reasonable temperature and/or electrical load

WORKING PRESSURE & TEMPERATURE

- 30 bar (450 PSI) non-shock cold working pressure
- -40°C to +170°C (-40°F to +350°F)
- **WARNING:** freezing of the fluid in the installation may severely damage the valve

UPON REQUEST

- Crimp/press end connections
- Stainless steel ball (1.4401 / AISI 316)
- Glass filled PTFE seals
- Custom design

PED DIRECTIVE

- According to 2014/68/UE module A: it cannot be used with dangerous gases in sizes larger than 25mm

APPROVED BY OR IN COMPLIANCE WITH

- RoHS Compliant (EU)
- KIWA Regulation 4 a.k.a. KUKreg4 (United Kingdom)
- EAC – Declaration of conformity (Russia, Kazakhstan, Belarus)
- Water Regulations Advisory Scheme (United Kingdom)

- **NOTE:** approvals apply to specific configurations/sizes only.

OPTIONS

- Oval lockable handle up to 2", round over 2" **1**
- Patented locking device **2**
- Geomet® carbon steel handle **3**
- **RuB** memory stop designed to be installed with our stubby handle
- T-handle **4**
- CW617N brass body and components **5**
- Brass stem extension **5**
- Stubby handle up to 2"



s.24 DZR XCES24I - 6012

Each user should perform his own tests to find out the suitability for his particular application. BONOMI INDUSTRIES makes no warranty, express or implied, as to the shape, fit or function of a product for any application. Contact us or consult with your supplier for additional information on the suitability of the BONOMI INDUSTRIES products with your specific field of use.



Part description		Q.ty	Material
1	Unplated body	1	CW602N
2	Ball seat	2	PTFE
3	Chrome plated ball	1	CW602N
4	Unplated end-cap	1	CW602N
5	Unplated stem O-ring design	1	CW602N
6	Stainless steel nut	1	1.4305/AISI303
7	O-Ring	2	FPM
8	White PVC coated stainless steel handle	1	1.4016/AISI430

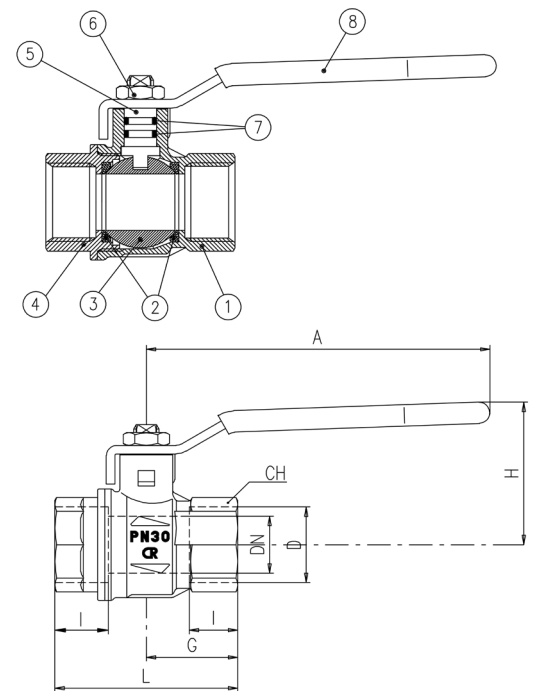

1 1/4"-2" hollow ball

Compliant to CE 2014/68/UE product Equipment category I Module A

Code	S24D00I	S24E00I	S24F00I	S24G00I	S24H00I	S24I00I	S24L00I	S24M00I	S24N00I
D (inch)	1/2"	3/4"	1"	1 1/4"	1 1/2"	2"	2 1/2"	3"	4"
DN (mm)	15	20	25	32	40	50	65	80	100
I (mm)	15.5	17	21	23	23	26.5	32	35	41.5
L (mm)	59	64	81	93	102	121	156	177	216
G (mm)	29.5	32	40.5	46.5	51	60.5	78	88.5	108
A (mm)	100	120	120	158	158	158	255	255	255
H (mm)	43	50	54	73	79	86	132	140	154
CH (mm)	25	31	40	49	54	68.5	85	99	125
Kv (m ³ /h)	28	42	70	80	125	179	516	776	1130

DN shows the nominal flow diameter. Actual flow diameter complies with full port DIN 3357 part 4. Stem configuration of valves over 2" is slightly different. Ball valves are marked CE on handle from 1 1/4" to 2", on body over 2" as follows: CE XXCODEXX Cat. I-A

PRESSURE-TEMPERATURE CHART

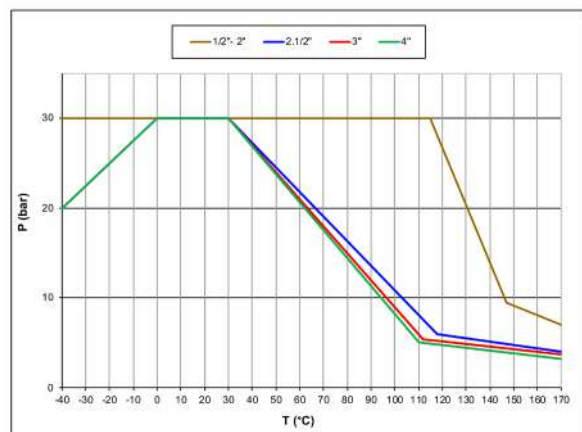

PRESSURE DROP CHART

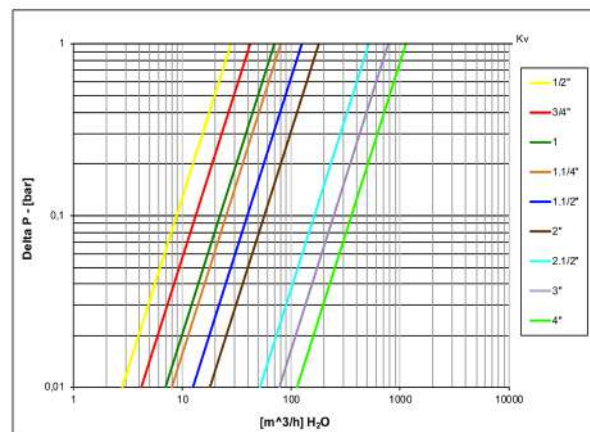



s.26 DZR

Female/Female
3/8" - 2"
ISO 228, for insulation, dezincification-resistant

Several governmental authorities recommend use of special alloys for valves handling water in areas where there is a problem of dezincification.

RuB DZR valves are designed to meet such requirements. Through the use of new technology these valves retain the reliability and competitiveness of brass, but are comparable to bronze in corrosion resistance.

Be kind with yourself, make sure the valve that brings you pure fresh water is an **RuB** DZR valve.



QUALITY

- 24h 100% seal test guaranteed
- Dual sealing system allows valve to be operated in either direction making installation easier
- No metal-to-metal moving parts
- No maintenance ever required
- Handle clearly shows ball position
- Silicone-free lubricant on all seals
- Chrome plated DZR brass ball for longer life
- Handle stops on body to avoid stress at stem

BODY

- Hot forged sand blasted DZR unplated body and cap sealed with Loctite® or equivalent thread sealant
- Dezincification resistant ADZ-T and ADZ-P brass approved to SBN-PFS 1983:2 and NR-BFS 1988:18 specifications
- Extended stem forged in one piece with body allows perfect sealing and easy operation when valve is isolated

STEM

- Maintenance-free, double FPM O-rings at the stem for maximum safety
- Unplated DZR brass stem

SEALING

- Pure PTFE self-lubricating seats with flexible-lip design

THREADS

- ISO 228 female by female threads

FLOW

- Full port to DIN 3357 for maximum flow

HANDLE

- Geomet® carbon steel handle with thick PVC dip coating. Handle coating offers both thermal and electrical protection
- Handle removable with valve in service
- **WARNING:** do not exceed reasonable temperature and/or electrical load

WORKING PRESSURE & TEMPERATURE

- 30 bar (450 PSI) non-shock cold working pressure
- -40°C to +170°C (-40°F to +350°F)
- **WARNING:** freezing of the fluid in the installation may severely damage the valve

UPON REQUEST

- CW617N brass body and components
- Stainless steel ball (1.4401 / AISI 316)
- Glass filled PTFE seals
- Custom design
- Male by female threads

PED DIRECTIVE

- According to 2014/68/UE module A: it cannot be used with dangerous gases in sizes larger than 25 mm

APPROVED BY OR IN COMPLIANCE WITH

- RoHS Compliant (EU)
- EAC – Declaration of conformity (Russia, Kazakhstan, Belarus)

NOTE: approvals apply to specific configurations/sizes only.

OPTIONS

- Oval lockable handle **1**
- Patented locking device **2**
- Stainless steel handle (1.4016 / AISI 430) **3**
- **RuB** memory stop designed to be installed with our stubby handle
- T-handle **4**
- Short stem design **5**
- Stubby handle



s.26 DZR XCES26 - 5940

Each user should perform his own tests to find out the suitability for his particular application. BONOMI INDUSTRIES makes no warranty, express or implied, as to the shape, fit or function of a product for any application. Contact us or consult with your supplier for additional information on the suitability of the BONOMI INDUSTRIES products with your specific field of use.



Part description	Q.ty	Material
1 Unplated body	1	CW602N
2 Ball seat	2	PTFE
3 Chrome plated ball	1	CW602N
4 Unplated end-cap	1	CW602N
5 Unplated extended stem O-ring design	1	CW602N
6 O-Ring	2	FPM
7 Unplated nut	1	CW617N
8 Geomet® nut	1	C4C EN10263-2)
9 White PVC coated Geomet® steel handle	1	DD11 EN10111)

1 1/4"-2" hollow ball

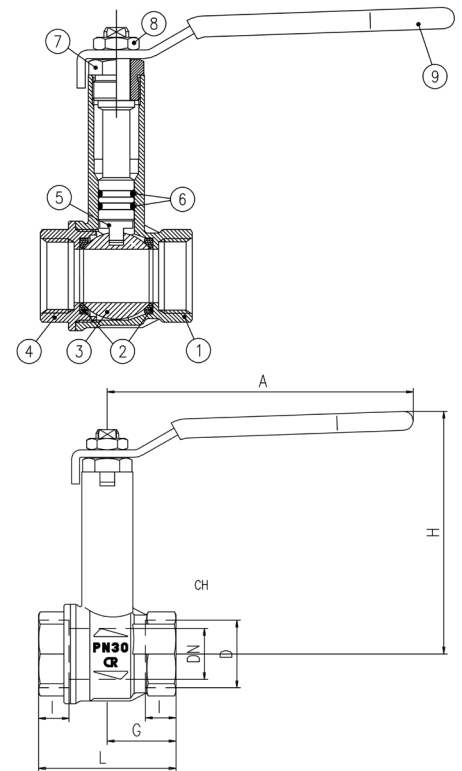

Code	S26C00	S26D00	S26E00	S26F00	S26G00	S26H00	S26I00
D (inch)	3/8"	1/2"	3/4"	1"	1 1/4"	1 1/2"	2"
DN (mm)	10	15	20	25	32	40	50
I (mm)	9	11	12	14	15	17	19
L (mm)	39	50	54	67	77	90	106
G (mm)	19.5	25	27	33.5	38.5	45	53
A (mm)	100	100	120	120	158	158	158
H (mm)	85	88	95	99	124	130	137
CH (mm)	20	25	31	38	48	54	66
Kv (m3/h)	8.2	28	42	70	80	125	179

DN shows the nominal flow diameter. Actual flow diameter complies with full port DIN 3357 part 4.

PRESSURE-TEMPERATURE CHART

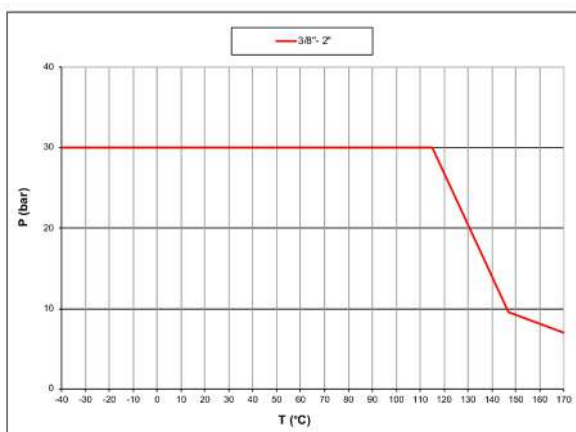

PRESSURE DROP CHART

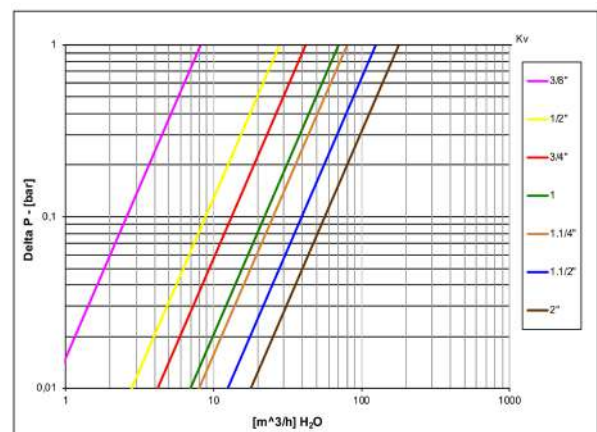



s.28 DZR

12 - 54 mm compression ends dezincification-resistant

Several governmental authorities recommend use of special alloys for valves handling water in areas where there is a problem of dezincification.

RuB DZR valves are designed to meet such requirements. Through the use of new technology these valves retain the reliability and competitiveness of brass, but are comparable to bronze in corrosion resistance.

Be kind with yourself, make sure the valve that brings you pure fresh water is an **RuB** DZR valve.



QUALITY

- 24h 100% seal test guaranteed
- Dual sealing system allows valve to be operated in either direction making installation easier
- No metal-to-metal moving parts
- No maintenance ever required
- Handle clearly shows ball position
- Silicone-free lubricant on all seals
- Handle stops on body to avoid stress at stem
- Chrome plated DZR brass ball for longer life

BODY

- Hot forged sand blasted DZR unplated body and cap sealed with Loctite® or equivalent thread sealant
- Dezincification resistant ADZ-T and ADZ-P brass approved to SBN- PFS 1983:2 and NR-BFS 1988:18 specifications

STEM

- Maintenance-free, double FPM O-rings at the stem for maximum safety
- Blowout-proof unplated DZR brass stem

SEALING

- Pure PTFE self-lubricating seats with flexible-lip design

CONNECTIONS

- Compression ends to EN 1254-2 and NKB no.12

FLOW

- Full port to DIN 3357 for maximum flow

HANDLE

- Geomet® carbon steel handle with thick PVC dip coating. Handle coating offers both thermal and electrical protection
- Handle removable with valve in service
- **WARNING:** do not exceed reasonable temperature and/or electrical load

WORKING PRESSURE & TEMPERATURE

- 16 bar (230 PSI) non-shock cold working pressure
- -20°C to +120°C (-4°F to +250°F)
- **WARNING:** freezing of the fluid in the installation may severely damage the valve

UPON REQUEST

- Stainless steel ball (1.4401 / AISI 316)
- Glass filled PTFE seals
- Custom design

PED DIRECTIVE

- The product described in this document meets the requirements of PED Directive 2014/68/UE and according to art.4 par.3, it does not require CE marking; it cannot be used with dangerous gases in sizes larger than 25mm

APPROVED BY OR IN COMPLIANCE WITH

- RoHS Compliant (EU)
- EAC – Declaration of conformity (Russia, Kazakhstan, Belarus)
- KIWA Regulation 4 a.k.a. KUKreg4 (United Kingdom) for sizes 12mm through 35mm
- Kiwa-Swedcert (Sweden)
- Ri.se. / Boverket (Sweden)
- Water Regulations Advisory Scheme (United Kingdom) for sizes 12mm through 35mm

NOTE: approvals apply to specific configurations/sizes only.

OPTIONS

- Oval lockable handle **1**
- Patented locking device **2**
- Stainless steel handle (1.4016 / AISI 430) **3**
- **RuB** memory stop designed to be installed with our stubby handle
- T-handle **4**
- Compression ends with extended stem for insulation **5**
- Brass stem extension **5**
- Stubby handle



s.28 DZR XGES28 - 5813

Each user should perform his own tests to find out the suitability for his particular application. BONOMI INDUSTRIES makes no warranty, express or implied, as to the shape, fit or function of a product for any application. Contact us or consult with your supplier for additional information on the suitability of the BONOMI INDUSTRIES products with your specific field of use.



Part description	Q.ty	Material
1 Unplated body	1	CW602N
2 Ball seat	2	PTFE
3 Chrome plated ball	1	CW602N
4 Unplated end-cap	1	CW602N
5 Olive	2	CW603N - CW508L - CW602N
6 Unplated nut	2	CW617N
7 Unplated stem O-ring design	1	CW602N
8 Geomet® nut	1	C4C (EN10263-2)
9 O-Ring	2	FPM
10 White PVC coated Geomet® steel handle	1	DD11 (EN10111)

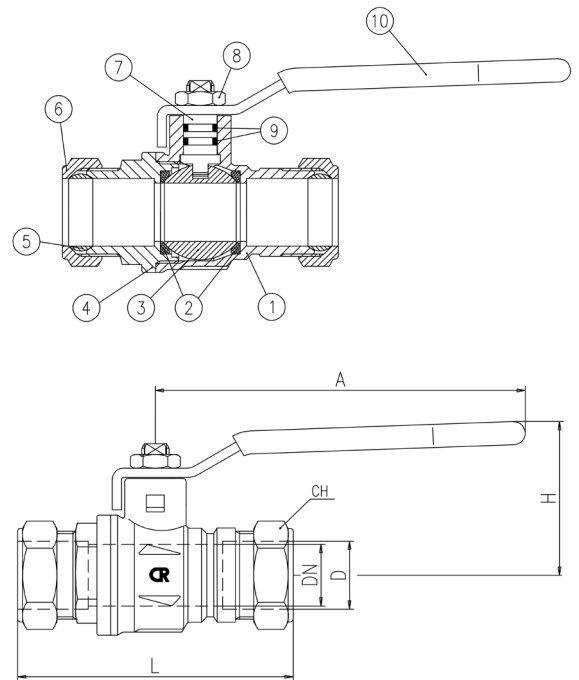

Hollow ball for D 35-42-54

Code	S28C12	S28D15	S28D18	S28E22	S28F28	S28G35	S28H42	S28I54
D (mm)	12	15	18	22	28	35	42	54
DN (mm)	10	15R	20R	20R	25R	32R	40R	50R
L (mm)	67	72	78.5	79	90.5	110	128.5	142
A (mm)	100	100	100	120	120	158	158	158
H (mm)	38	43	43	50	54	73	79	86
CH (mm)	19	24	27	32	38.5	48	54	70
Kv (m ³ /h)	8.2	28	28	42	70	80	125	179

DN shows the nominal flow diameter. Actual flow diameter complies with full port DIN 3357 part 4.

PRESSURE-TEMPERATURE CHART

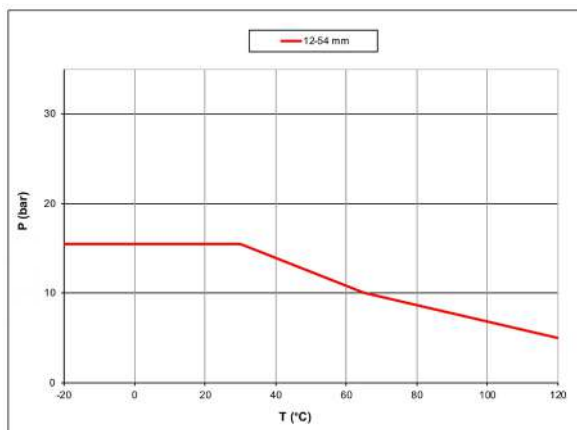

PRESSURE DROP CHART

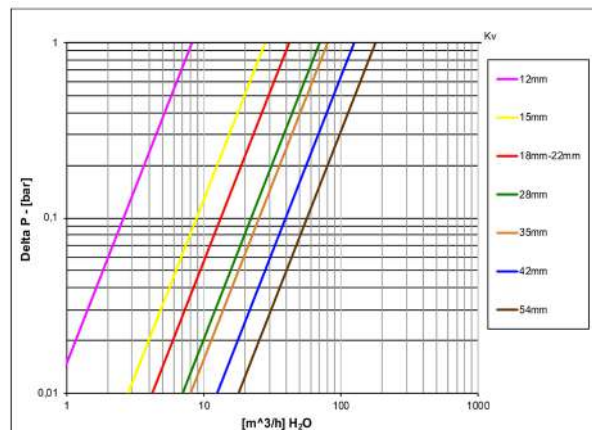



s.30 DZR

**12 - 54 mm compression ends
for insulation
dezincification-resistant**

Several governmental authorities recommend use of special alloys for valves handling water in areas where there is a problem of dezincification.

RuB DZR valves are designed to meet such requirements. Through the use of new technology these valves retain the reliability and competitiveness of brass, but are comparable to bronze in corrosion resistance.

Be kind with yourself, make sure the valve that brings you pure fresh water is an **RuB** DZR valve.



QUALITY

- 24h 100% seal test guaranteed
- Dual sealing system allows valve to be operated in either direction making installation easier
- No metal-to-metal moving parts
- No maintenance ever required
- Handle clearly shows ball position
- Silicone-free lubricant on all seals
- Handle stops on body to avoid stress at stem
- Chrome plated DZR brass ball for longer life

BODY

- Hot forged sand blasted DZR unplated body and cap sealed with Loctite® or equivalent thread sealant
- Dezincification resistant ADZ-T and ADZ-P brass approved to SBN-PFS 1983:2 and NR-BFS 1988:18 specifications
- Extended stem forged in one piece with body allows perfect sealing and easy operation when valve is isolated

STEM

- Maintenance-free, double FPM O-rings at the stem for maximum safety
- Unplated DZR brass stem

SEALING

- Pure PTFE self-lubricating seats with flexible-lip design

CONNECTIONS

- Compression ends to EN 1254-2 and NKB no.12

FLOW

- Full port to DIN 3357 for maximum flow

HANDLE

- Geomet® carbon steel handle with thick PVC dip coating. Handle coating offers both thermal and electrical protection
- Handle removable with valve in service
- **WARNING:** do not exceed reasonable temperature and/or electrical load

WORKING PRESSURE & TEMPERATURE

- 16 bar (230 PSI) non-shock cold working pressure
- -20°C to +120°C (-4°F to +250°F)
- **WARNING:** freezing of the fluid in the installation may severely damage the valve

UPON REQUEST

- Stainless steel ball (1.4401 / AISI 316)
- Glass filled PTFE seals
- Custom design

PED DIRECTIVE

- The product described in this document meets the requirements of the PED Directive 2014/68/UE and according to art.4 par.3, it does not require CE marking; it cannot be used with dangerous gases in sizes larger than 25 mm

APPROVED BY OR IN COMPLIANCE WITH

- RoHS Compliant (EU)
- EAC – Declaration of conformity (Russia, Kazakhstan, Belarus)
- Kiwa-Swedcert (Sweden)
- Ri.se. / Boverket (Sweden)

NOTE: approvals apply to specific configurations/sizes only.

OPTIONS

- Oval lockable handle **1**
- Patented locking device **2**
- Stainless steel handle (1.4016 / AISI 430) **3**
- T-handle **4**
- **RuB** memory stop designed to be installed with our stubby handle
- Short stem design **5**
- Stubby handle



s.30 DZR XCES30 - 5813

Each user should perform his own tests to find out the suitability for his particular application. BONOMI INDUSTRIES makes no warranty, express or implied, as to the shape, fit or function of a product for any application. Contact us or consult with your supplier for additional information on the suitability of the BONOMI INDUSTRIES products with your specific field of use.



DRINKING WATER

Part description	Q.ty	Material
1 Unplated body	1	CW602N
2 Ball seat	2	PTFE
3 Chrome plated ball	1	CW602N
4 Unplated end-cap	1	CW602N
5 Olive	2	CW603N - CW508L - CW602N
6 Unplated nut	2	CW617N
7 Unplated extended stem O-ring design	1	CW602N
8 O-Ring	2	FPM
9 Unplated nut	1	CW617N
10 Geomet® nut	1	C4C (EN10263-2)
11 White PVC coated Geomet® steel handle	1	DD11 (EN10111)

Hollow ball for D 35-42-54

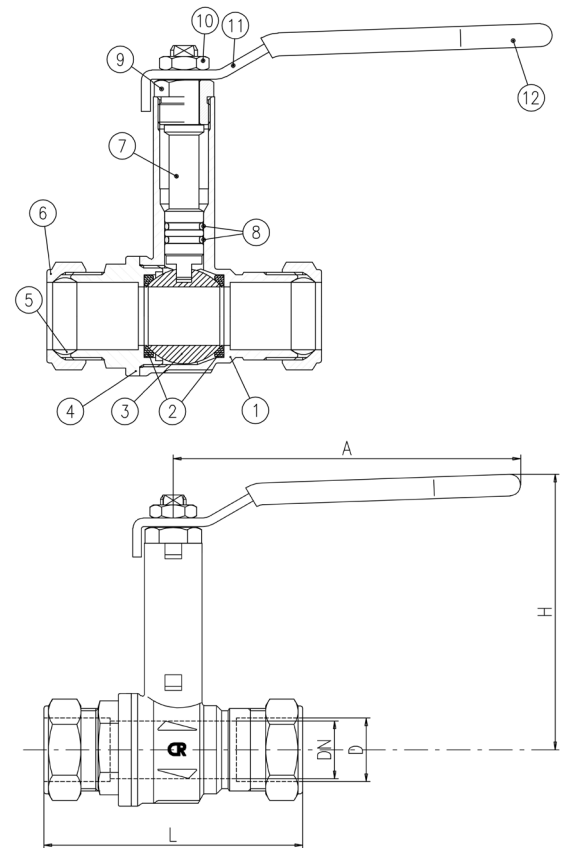

Code	S30C12	S30D15	S30D18	S30E22	S30F28	S30G35	S30H42	S30I54
D (mm)	12	15	18	22	28	35	42	54
DN (mm)	10	15R	15R	20R	25R	32R	40R	50R
L (mm)	67	72	78.5	79	90.5	110	128.5	142
A (mm)	100	100	100	120	120	158	158	158
H (mm)	85	88	88	95	99	124	130	137
CH (mm)	19	24	27	32	38.5	48	54	70
Kv (m ³ /h)	8.2	28	28	42	70	80	125	179

DN shows the nominal flow diameter. Actual flow diameter complies with full port DIN 3357 part 4.

PRESSURE-TEMPERATURE CHART

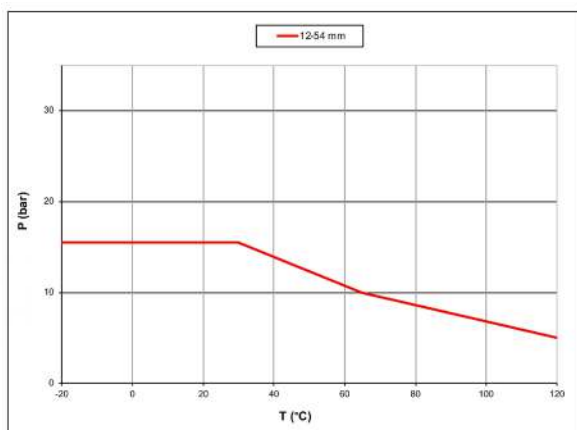

PRESSURE DROP CHART

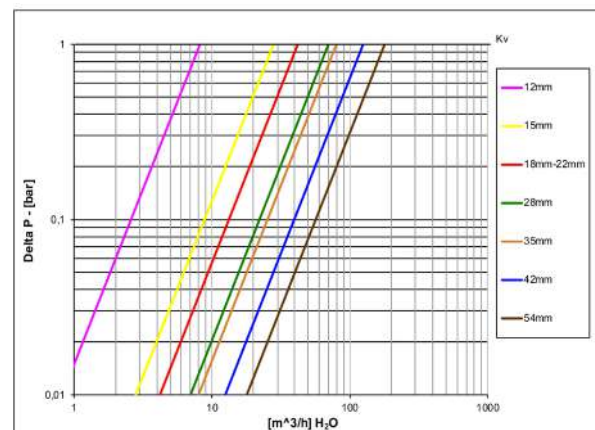



s.84 W

Female/Female
1/4" - 2"
EN 10226-1

Legionella is a bacterium that lives and proliferates in natural and artificial aquatic environments at temperatures ranging between 5.7°C and 55°C and standing up to acidic and alkaline environments. New s.84W is approved for use with drinking water; the specific ball design avoids water stagnation and the spread of bacteria in the system.

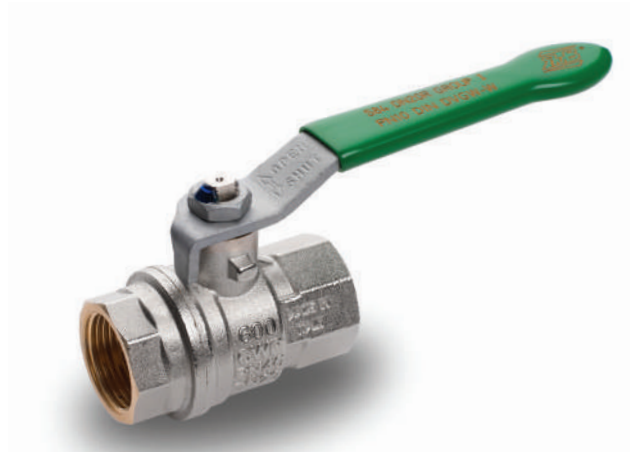

QUALITY

- 24h 100% seal test guaranteed
- Dual sealing system allows valve to be operated in either direction making installation easier
- No metal-to-metal moving parts
- No maintenance ever required
- Handle clearly shows ball position
- Silicone-free lubricant on all seals
- Handle stops on body to avoid stress at stem
- Chrome plated brass ball with rinse hole

BODY

- Hot forged sand blasted, external nickel plated brass body and cap sealed with Loctite® or equivalent thread sealant
- Finest brass according to EN 12165 and EN 12164 specifications

STEM

- Blowout-proof nickel plated brass stem
- Maintenance-free, double EPDM O-rings at the stem for maximum safety

SEALING

- Pure PTFE self-lubricating seats with flexible-lip design

THREADS

- EN 10226-1, ISO 228 parallel female by female threads

FLOW

- Full port to DIN 3357 for maximum flow

HANDLE

- Geomet® carbon steel handle with thick PVC dip coating. Handle coating offers both thermal and electrical protection
- Handle removable with valve in service
- **WARNING:** do not exceed reasonable temperature and/or electrical load

WORKING PRESSURE & TEMPERATURE

- 40 bar (600 PSI) non-shock cold working pressure
- DIN-EN 13828 limitations for potable water: 10 bar (Kg/cm²) non- shock cold working pressure and +65°C temperature (occasional excursions up to 90°C are permitted for a period of 1 h maximum)
- -40°C to +150°C (-40°F to +302°F)
- **WARNING:** freezing of the fluid in the installation may severely damage the valve

UPON REQUEST

- Glass filled PTFE seals
- Stainless steel handle (1.4016 / AISI 430)
- Special configuration for industrial oxygen application
- Custom design

PED DIRECTIVE

- According to 2014/68/UE module A: it cannot be used with dangerous gases in sizes larger than 25mm

APPROVED BY OR IN COMPLIANCE WITH

- RoHS Compliant (EU)
- DVGW (Germany)
- EAC – Declaration of conformity (Russia, Kazakhstan, Belarus)
- Water Regulations Advisory Scheme (United Kingdom)
- Attestation de Conformité Sanitaire (France)

NOTE: approvals apply to specific configurations/sizes only.

OPTIONS

- Patented locking device **1**
- T-handle **2**
- Stubby handle
- Stem extension
- **RuB** memory stop designed to be installed with our stubby handle



s.84 W XCES84W - 6012

Each user should perform his own tests to find out the suitability for his particular application. BONOMI INDUSTRIES makes no warranty, express or implied, as to the shape, fit or function of a product for any application. Contact us or consult with your supplier for additional information on the suitability of the BONOMI INDUSTRIES products with your specific field of use.



DRINKING WATER

Part description		Q.ty	Material
1	Nickel plated body (external treatment)	1	CW617N
2	Seat	2	PTFE
3	Chrome plated ball with rinse hole (rinse hole on sizes from 3/4" up to 2")	1	CW617N
4	Nickel plated end-cap (external treatment)	1	CW617N
5	Nickel plated stem O-ring design	1	CW617N
6	Geomet® nut	1	C4C (EN10263-2)
7	O-Ring	2	EPDM
8	Green PVC coated Geomet® steel handle	1	DD11 (EN10111)

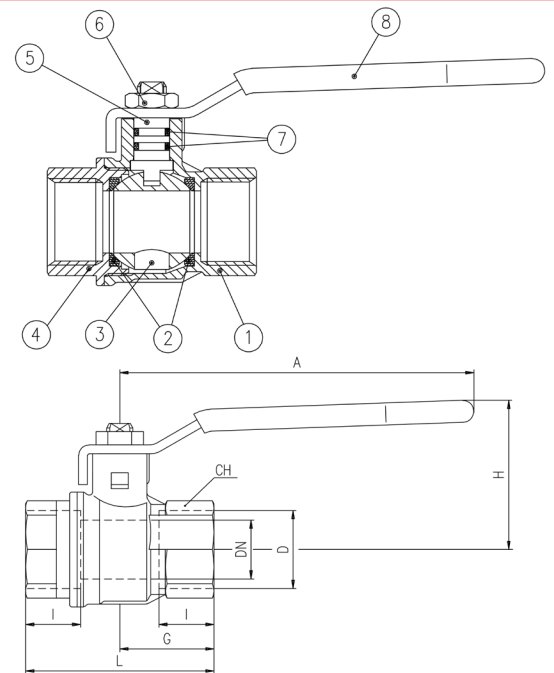

1 1/4" to 2" hollow ball

Compliant to CE 2014/68/UE product Equipment category I Module A

Code	S84B00W	S84C00W	S84D00W	S84E00W	S84F00W	S84G00W	S84H00W	S84I00W
D (inch)	1/4"	3/8"	1/2"	3/4"	1"	1 1/4"	1 1/2"	2"
DN(mm)	8	10	15	20	25	32	40	50
I (mm)	12	12	15,5	17	21	23	23	26,5
L (mm)	45	45	59	64	81	93	102	121
G (mm)	22,5	22,5	29,5	32	40,5	46,5	51	60,5
A (mm)	82	82	100	120	120	158	158	158
H (mm)	38	38	43	50	54	73	79	86
CH (mm)	17	20	25	31	40	49	54	68,5
Kv(m3/h)	3,9	8,2	28	36	62	79	124	178

DN shows the nominal flow diameter. Actual flow diameter complies with full port DIN 3357 part 4.

Ball valves are marked CE on handle from 1 1/4" to 2" as follow: CE XXCODEXX Cat I-A

PRESSURE-TEMPERATURE CHART

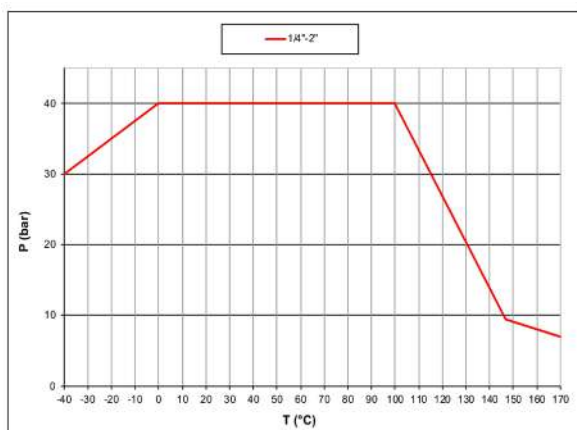

PRESSURE DROP CHART

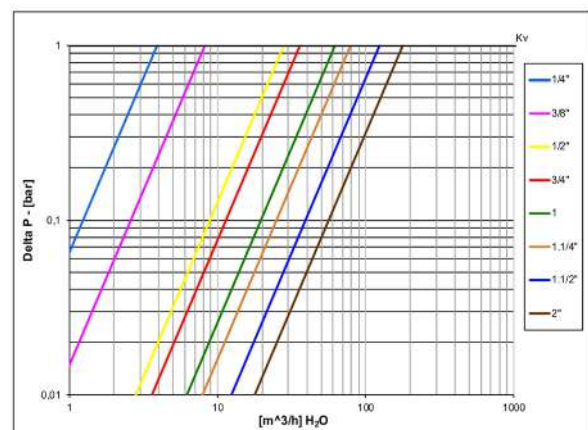



s.84 W M/F

Male/Female
1/4" - 2"
EN 10226-1

Legionella is a bacterium that lives and proliferates in natural and artificial aquatic environments at temperatures ranging between 5.7°C and 55°C and standing up to acidic and alkaline environments. New s.84W is approved for use with drinking water; the specific ball design avoids water stagnation and the spread of bacteria in the system.



QUALITY

- 24h 100% seal test guaranteed
- Dual sealing system allows valve to be operated in either direction making installation easier
- No metal-to-metal moving parts
- No maintenance ever required
- Handle clearly shows ball position
- Silicone-free lubricant on all seals
- Handle stops on body to avoid stress at stem
- Chrome plated brass ball with rinse hole

BODY

- Hot forged sand blasted, external nickel plated brass body and cap sealed with Loctite® or equivalent thread sealant
- Finest brass according to EN 12165 and EN 12164 specifications

STEM

- Blowout-proof nickel plated brass stem
- Maintenance-free, double EPDM O-rings at the stem for maximum safety

SEALING

- Pure PTFE self-lubricating seats with flexible-lip design

THREADS

- EN 10226-1, ISO 228 parallel female thread by EN10226-1, ISO7/1 taper male thread

FLOW

- Full port to DIN 3357 for maximum flow

HANDLE

- Geomet® carbon steel handle with thick PVC dip coating. Handle coating offers both thermal and electrical protection
- Handle removable with valve in service
- **WARNING:** do not exceed reasonable temperature and/or electrical load

WORKING PRESSURE & TEMPERATURE

- 40 bar (600 PSI) non-shock cold working pressure
- DIN-EN 13828 limitations for potable water: 10 bar (Kg/cm²) non- shock cold working pressure and +65°C temperature (occasional excursions up to 90°C are permitted for a period of 1 h maximum)
- -40°C to +150°C (-40°F to +302°F)
- **WARNING:** freezing of the fluid in the installation may severely damage the valve

UPON REQUEST

- Glass filled PTFE seals
- Stainless steel handle (1.4016 / AISI 430)
- Special configuration for industrial oxygen application
- Custom design

PED DIRECTIVE

- According to 2014/68/UE module A: it cannot be used with dangerous gases in sizes larger than 25mm

APPROVED BY OR IN COMPLIANCE WITH

- RoHS Compliant (EU)
- DVGW (Germany)
- EAC – Declaration of conformity (Russia, Kazakhstan, Belarus)
- Water Regulations Advisory Scheme (United Kingdom)
- Attestation de Conformité Sanitaire (France)

NOTE: approvals apply to specific configurations/sizes only.

OPTIONS

- Patented locking device ①
- T-handle ②
- Stubby handle
- Stem extension
- **RUB** memory stop designed to be installed with our stubby handle



s.84 W MF XGES84WM - 6012

Each user should perform his own tests to find out the suitability for his particular application. BONOMI INDUSTRIES makes no warranty, express or implied, as to the shape, fit or function of a product for any application. Contact us or consult with your supplier for additional information on the suitability of the BONOMI INDUSTRIES products with your specific field of use.



DRINKING WATER

Part description		Q.ty	Material
1	Nickel plated body (external treatment)	1	CW617N
2	Seat	2	PTFE
3	Chrome plated ball with rinse hole (rinse hole on sizes from 3/4" up to 2")	1	CW617N
4	Nickel plated end-cap (external treatment)	1	CW617N
5	Nickel plated stem O-ring design	1	CW617N
6	Geomet® nut	1	C4C (EN10263-2)
7	O-Ring	2	EPDM
8	Green PVC coated Geomet® steel handle	1	DD11 (EN10111)

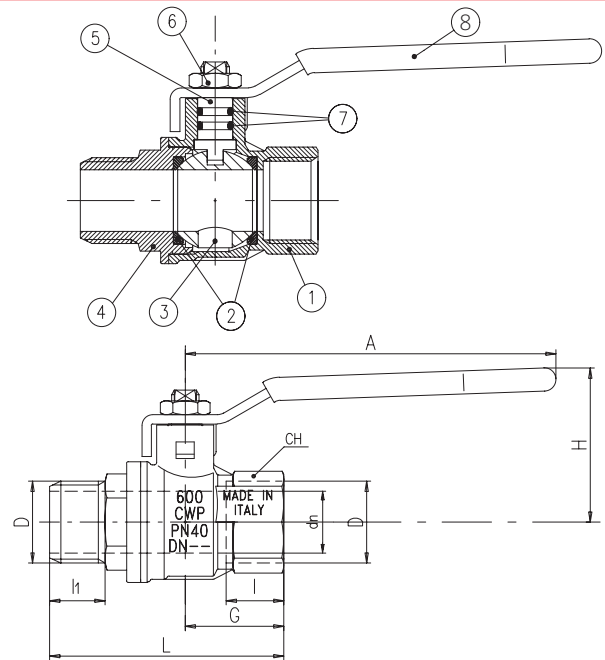

1 1/4" to 2" hollow ball

Compliant to CE 2014/68/UE product Equipment category I Module A

Code	S84B20W	S84C20W	S84D20W	S84E20W	S84F20W	S84G20W	S84H20W	S84I20W
D (inch)	1/4"	3/8"	1/2"	3/4"	1"	1 1/4"	1 1/2"	2"
DN (mm)	8	10	15	20	25	32	40	50
I (mm)	12	12	15.5	17	21	23	23	26.5
I1 (mm)	13.5	13.5	16.5	18	22	24	24	27.5
L (mm)	56.5	56.5	70	76.5	92.5	106	113	133
G (mm)	22.5	22.5	29.5	32	40.5	46.5	51	60.5
A (mm)	82	82	100	120	120	158	158	158
H (mm)	38	38	43	50	54	73	79	86
CH (mm)	17	20	25	31	40	49	54	68.5
Kv (m3/h)	3.9	8.2	28	36	62	79	124	178

DN shows the nominal flow diameter. Actual flow diameter complies with full port DIN 3357 part 4.

Ball valves are marked CE on handle from 1 1/4" to 2" as follow: CE XXCODEXX Cat I-A

PRESSURE-TEMPERATURE CHART

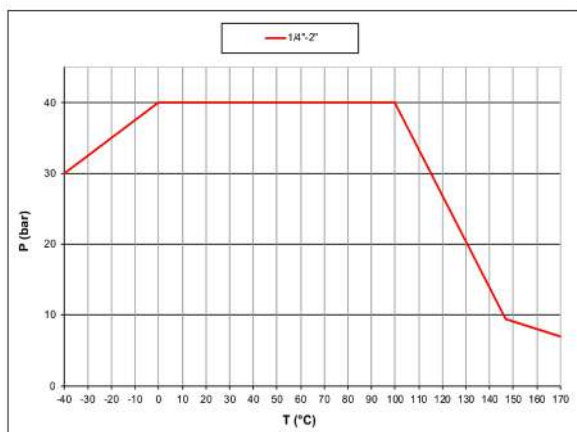

PRESSURE DROP CHART

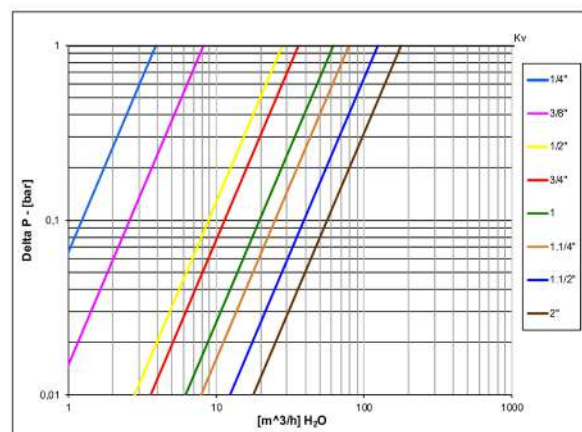

s.84W M/F

Male/Female 3/4" for flat gasket

Legionella is a bacterium that lives and proliferates in natural and artificial aquatic environments at temperatures ranging between 5.7°C and 55°C and standing up to acidic and alkaline environments.

New s.84AW is approved for use with drinking water; the specific ball design avoids water stagnation and the spread of bacteria in the system.

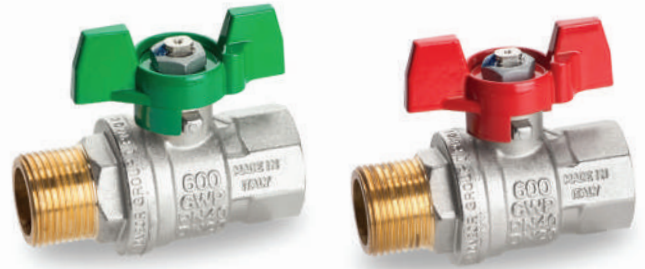

QUALITY

- 24h 100% seal test guaranteed
- Dual sealing system allows valve to be operated in either direction making installation easier
- The valve is provided with a flat sealing surface at male thread that offers an improved performance compared to conventional connections; a wider seal surface guarantees higher sealing, reliable over time
- No metal-to-metal moving parts
- No maintenance ever required
- T-handle clearly shows ball position
- Silicone-free lubricant on all seals
- Handle stops on body to avoid stress at stem
- Chrome plated brass ball with rinse hole

BODY

- Hot forged sand blasted, external nickel plated brass body and cap sealed with Loctite® or equivalent thread sealant
- Finest brass according to EN 12165 and EN 12164 specifications

STEM

- Blowout-proof nickel plated brass stem
- Maintenance-free, double EPDM O-rings at the stem for maximum safety

SEALING

- Pure PTFE self-lubricating seats with flexible-lip design

THREADS

- EN 10226-1, ISO228 parallel female by ISO228 male threads

FLOW

- Full port to DIN 3357 for maximum flow

HANDLE

- Aluminum T-handle enameled green or red
- T-handle removable with valve in service
- **WARNING:** do not exceed reasonable temperature and/or electrical load

WORKING PRESSURE & TEMPERATURE

- 40 bar (600 PSI) non-shock cold working pressure
- DIN-EN 13828 limitations for potable water: 10 bar (Kg/cm²) non-shock cold working pressure and +65°C temperature (occasional excursions up to 90°C are permitted for a period of 1 h maximum)
- -40°C to +150°C (-40°F to +302°F)
- **WARNING:** freezing of the fluid in the installation may severely damage the valve

UPON REQUEST

- Stem extension
- Stainless steel ball (1.4401 / AISI 316)
- Glass filled PTFE seals
- Custom design

PED DIRECTIVE

- The product meets the requirements of PED Directive 2014/68/UE and according to art.4 par.3, it does not require CE marking

APPROVED BY OR IN COMPLIANCE WITH

- RoHS Compliant (EU)
- DVGW (Germany)
- EAC – Declaration of conformity (Russia, Kazakhstan, Belarus)
- Attestation de Conformité Sanitaire (France)

NOTE: approvals apply to specific configurations/sizes only

OPTIONS

- Patented locking device **1**
- Geomet® carbon steel handle with thick PVC dip coating. Handle coating offers both thermal and electrical protection **2**
- Stubby handle
- **RuB** memory stop designed to be installed with our stubby handle

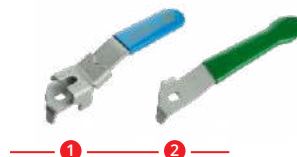

s.84 W MF FLAT GASKET XCES84AW - 5813

Each user should perform his own tests to find out the suitability for his particular application. BONOMI INDUSTRIES makes no warranty, express or implied, as to the shape, fit or function of a product for any application. Contact us or consult with your supplier for additional information on the suitability of the BONOMI INDUSTRIES products with your specific field of use.



Part description	Q.ty	Material
1 Nickel plated body (external nickel plated, unplated inside)	1	CW617N
2 Seat	2	PTFE
3 Chrome plated ball with rinse hole	1	CW617N
4 Nickel plated male end-cap (external nickel plated, unplated inside)	1	CW617N
5 Nickel plated stem O-ring design	1	CW617N
6 Geomet® nut	1	C4C (EN10263-2)
7 O-Ring	2	EPDM
8 Green or red T-handle	1	EN AC-46100

Code	S84E26AW	S84E26AWR
D (inch)	Rp 3/4" (EN10226 - ISO228)	Rp 3/4" (EN10226 - ISO228)
D1 (inch)	G3/4" B (ISO228)	G3/4" B (ISO228)
DN (mm)	19	19
I (mm)	17	17
I1 (mm)	18	18
L (mm)	76,5	76,5
G (mm)	32	32
A (mm)	30	30
H (mm)	49	49
CH (mm)	31	31
T-handle	Green	Red
Kv (m3/h)	36	36

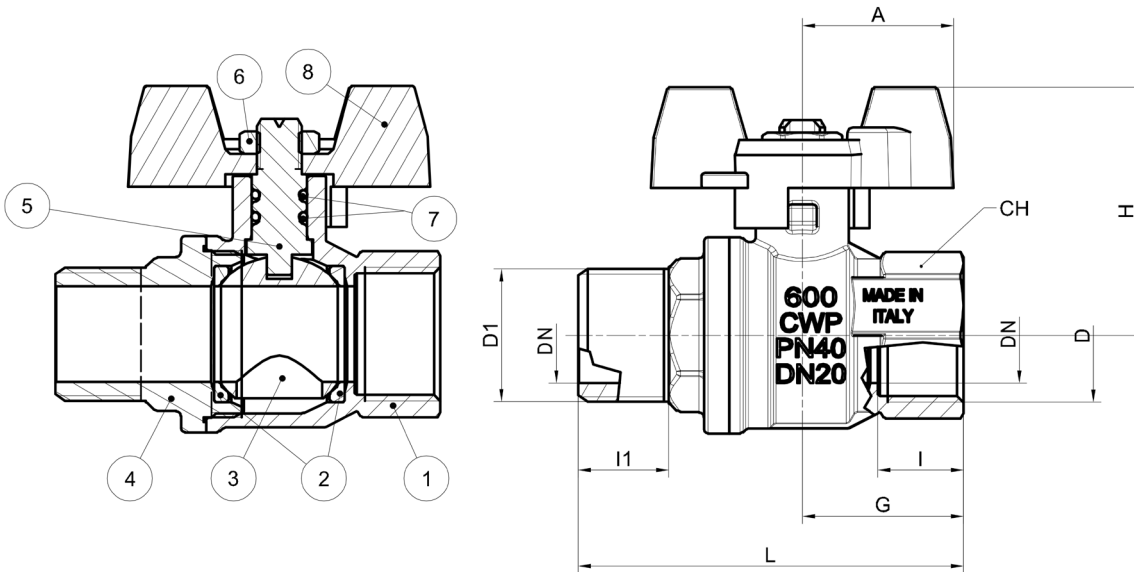

DN shows the nominal flow diameter. Actual flow diameter complies with full port DIN 3357 part 4.

PRESSURE-TEMPERATURE CHART

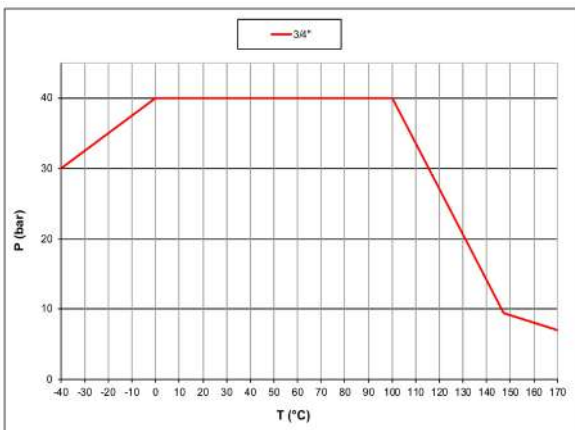

PRESSURE DROP CHART

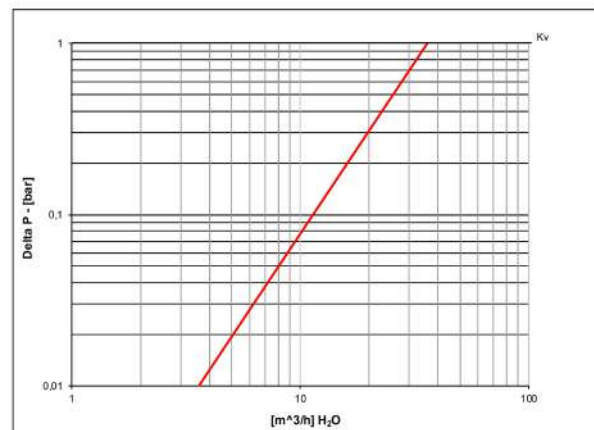



S.468LF DZR

22 mm compression ends
ISO 5211

Lead-Free, dezincification-resistant



QUALITY

- 100% seal test guaranteed
- Arrow on the valve body clearly shows the flow direction
- No metal-to-metal moving parts
- No maintenance ever required
- Stem clearly shows ball position
- Silicone-free lubricant on all seals
- Chrome plated DZR and lead free brass ball for longer life and with antifreeze function

BODY

- Hot forged sand blasted DZR and lead free unplated body and cap sealed with Loctite® or equivalent thread sealant
- Dezincification-resistant and lead free brass in compliance with HCACL Hygienic copper alloy composition (UBA list)

STEM

- Maintenance-free, double EPDM O-rings at the stem for maximum safety
- Blowout-proof unplated DZR and lead free brass stem

SEALING

- EPDM seats for lower torque

THREADS

- Compression ends to EN 1254-2

FLOW

- Full port to DIN 3357 for maximum flow

HANDLE

- Integrated sturdy ISO 5211 flange allows direct mounting of electric and pneumatic actuators, with no bracket or coupling required. See **RuB** line of electric and pneumatic actuators.

WORKING PRESSURE & TEMPERATURE

- Shell rating: 40 bar (600 PSI) non-shock cold working pressure
- Seat rating/compression ends: 16 bar max (230 PSI max) non-shock cold working pressure (see chart for pressure/temperature limits)
- -20°C to +120°C (-4°F to +250°F)
- **WARNING:** freezing of the fluid in the installation may severely damage the valve

UPON REQUEST

- Custom design

PED DIRECTIVE

- The product described in this document meets the requirements of PED Directive 2014/68/UE and according to art.4 par.3, it does not require CE marking

APPROVED BY OR IN COMPLIANCE WITH

- Certified by CSA International for Drinking Water to NSF/ANSI 372 (United States)
- Water Regulations Advisory Scheme (United Kingdom)

NOTE: approvals apply to specific configurations/sizes only.

OPTIONS

- S.468 DZR and lead free 7/8" compression ends
- Rack and pinion pneumatic actuator (spring return or double acting)
- Compact power electric actuator
- Manual lockable handle

s.468LF DZR XGES468 - 5466

Each user should perform his own tests to find out the suitability for his particular application. BONOMI INDUSTRIES makes no warranty, express or implied, as to the shape, fit or function of a product for any application. Contact us or consult with your supplier for additional information on the suitability of the BONOMI INDUSTRIES products with your specific field of use.



Part description	Q.ty	Material
1 Unplated body	1	CW511L
2 Seat	2	EPDM
3 Chrome plated ball	1	CW511L
4 Unplated end-cap	1	CW511L
5 Unplated stem	1	CW511L
6 O-Ring	2	EPDM
7 Washer	1	PTFE carbon filled 25%
8 Olive	2	CW508L
9 Unplated nut	2	CW617N

Code	S468E22
D (inch)	22
DN(mm)	19
L (mm)	87,5
G (mm)	40,7
H (mm)	33,5
ØA (mm)	36
ØC (mm)	Ø5.2 (M6)
Square B (mm)	9
ØM (mm)	43,4
F (mm)	8,3
CH (mm)	32
Kv (m3/h)	36

DN shows the nominal flow diameter. Actual flow diameter complies with full port DIN 3357 part 4.

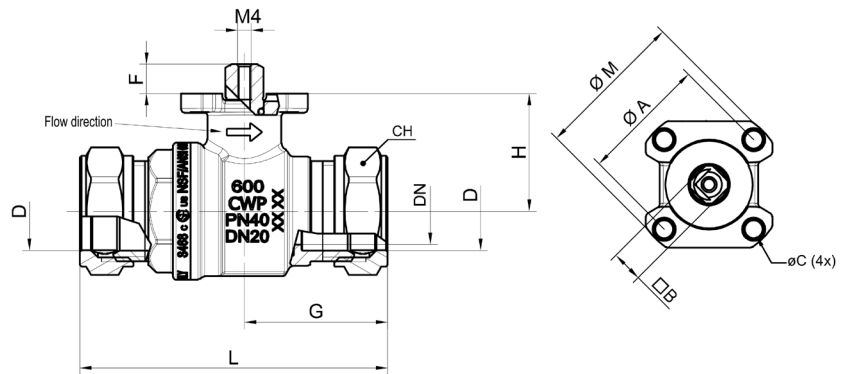
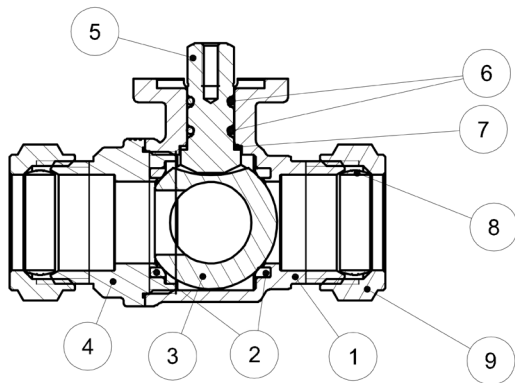

TORQUE FOR ACTUATOR SIZING N.M

Delta P -->	0÷6 bar	6÷16 bar
Valve size	<i>to open/to close</i>	<i>to open/to close</i>
22 mm	2,5	3

PRESSURE-TEMPERATURE CHART

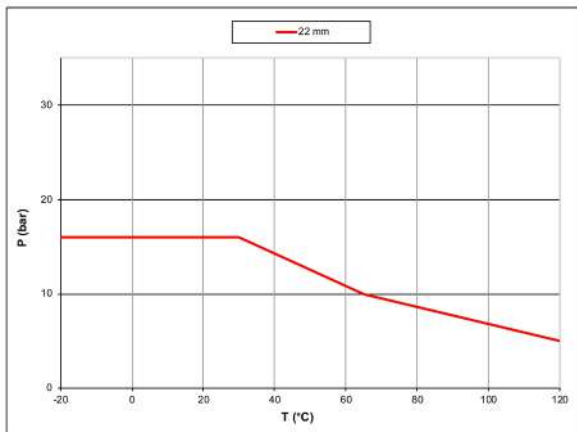

PRESSURE DROP CHART

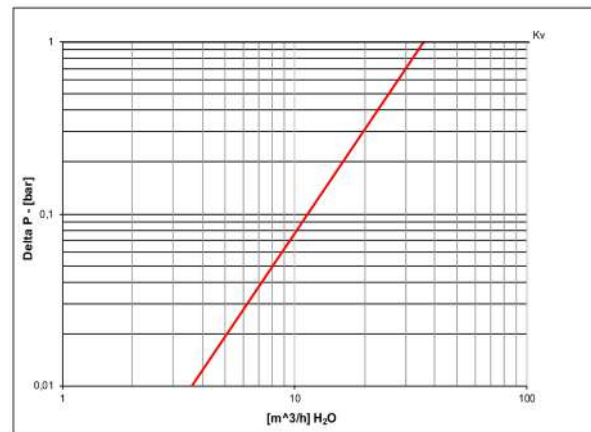



Puri-T 292 NPT

Female/Female
1/4" - 2"
Lead Free

All surfaces of this product in contact with drinking water contain less than 0.25% of lead in compliance with U.S. law



QUALITY

- Certified by CSA International to comply with U.S. s3874, California AB1953, and similar laws of other states for the safe handling of drinking water
- 24h 100% seal test guaranteed
- Dual sealing system allows valve to be operated in either direction making installation easier
- No metal-to-metal moving parts
- Handle clearly shows ball position
- Silicone-free lubricant on all seals
- Handle stops on body to avoid stress at stem

BODY

- Hot forged sand blasted, unplated lead free brass body and cap sealed with Loctite® or equivalent thread sealant
- Chrome plated lead free brass ball for longer life

STEM

- Pure PTFE adjustable packing gland and reinforced washer for lower torque and easy maintenance
- Blowout-proof unplated lead free brass stem

SEALING

- Glass filled pure PTFE self-lubricating seats with flexible-lip design

THREADS

- NPT taper ANSI B.1.20.1 female by female threads

FLOW

- Full port to DIN 3357 for maximum flow

HANDLE

- Geomet® carbon steel handle with thick PVC dip coating. Handle coating offers both Thermal and electrical protection
- **WARNING:** do not exceed reasonable temperature and/or electrical load

WORKING PRESSURE & TEMPERATURE

- 600 PSI non-shock cold working pressure
- For general use: -40°F / +350°F (-40°C to +170°C)
- NSF 61 limits (CSA approval): tested for use in continuous exposure to water of ambient temperature
- **WARNING:** freezing of the fluid in the installation may severely damage the valve

UPON REQUEST

- Custom design
- Pure PTFE seals
- * For sales within EU: CE marking needed, please contact us

APPROVED BY OR IN COMPLIANCE WITH

- EAC – Declaration of conformity (Russia, Kazakhstan, Belarus)
- Certified by CSA International for Drinking Water to NSF/ANSI 61 – NSF/ANSI 372 (United States)
- RoHS Compliant (EU)

NOTE: approvals apply to specific configurations/sizes only.

OPTIONS

- Oval lockable handle **1**
- Patented locking device **2**
- Stem extension
- Stainless steel handle (1.4016 / AISI 430) **3**
- Stubby handle **4**
- T-handle **5**



PURI-T 292 NPT XCET292 - 6012

Each user should perform his own tests to find out the suitability for his particular application. BONOMI INDUSTRIES makes no warranty, express or implied, as to the shape, fit or function of a product for any application. Contact us or consult with your supplier for additional information on the suitability of the BONOMI INDUSTRIES products with your specific field of use.



Part description	Q.ty	Material
1 Unplated NPT body	1	CW510L
2 Seat	2	PTFE glass filled 5-15%
3 Chrome plated ball	1	CW510L
4 Unplated NPT end-cap	1	CW510L
5 Unplated stem packing gland design	1	CW510L
6 Nickel plated gland nut	1	CW617N
7 Geomet® nut	1	CB4FF (EN10263-2)
8 Packing gland seal	1	PTFE
9 Thrust washer	1	PTFE carbon filled 25%
10 Green PVC coated Geomet® steel handle	1	DD11 (EN10111)

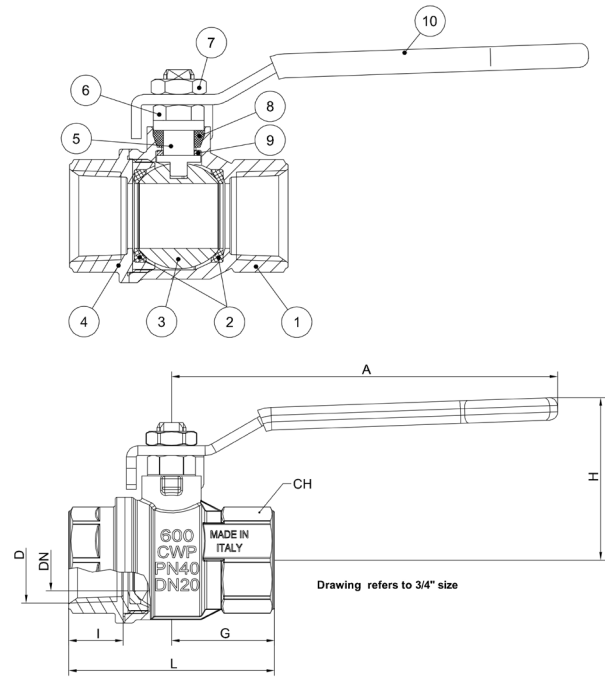

1 1/2"-2" hollow ball

For sales within EU: CE marking needed, please contact us

Code	T292B41	T292C41	T292D41	T292E41	T292F41	T292G41	T292H41	T292I41
D (inch)	1/4"	3/8"	1/2"	3/4"	1"	1 1/4"	1 1/2"	2"
DN (inch)	0.315	0.374	0.591	0.748	0.945	1.181	1.496	1.890
I (inch)	0.472	0.472	0.610	0.669	0.827	0.906	0.906	1.043
L (inch)	1.772	1.772	2.323	2.520	3.189	3.661	4.016	4.764
G (inch)	0.886	0.886	1.161	1.259	1.594	1.831	2.007	2.381
A (inch)	3.228	3.228	3.937	4.724	4.724	6.220	6.220	6.220
H (inch)	1.575	1.575	1.693	1.968	2.165	2.992	3.228	3.504
CH (inch)	0.669	0.787	0.984	1.220	1.574	1.929	2.126	2.697
Cv (GPM)	4.5	9.5	32.3	48.5	80.9	127.1	144.4	206.8

DN shows the nominal flow diameter. Actual flow diameter complies with full port DIN 3357 part 4.

PRESSURE-TEMPERATURE CHART

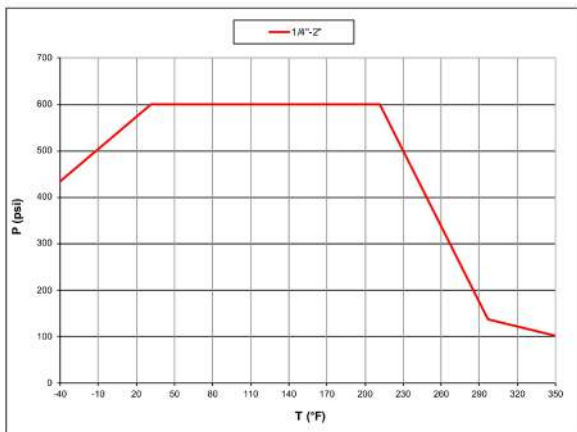

PRESSURE DROP CHART

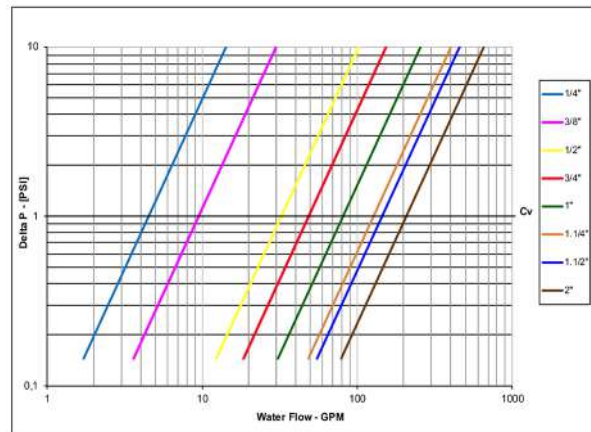



Puri-T 242

1/2" - 2"
Lead Free
solder ends

All surfaces of this product in contact with drinking water contain less than 0.25% of lead in compliance with U.S. law

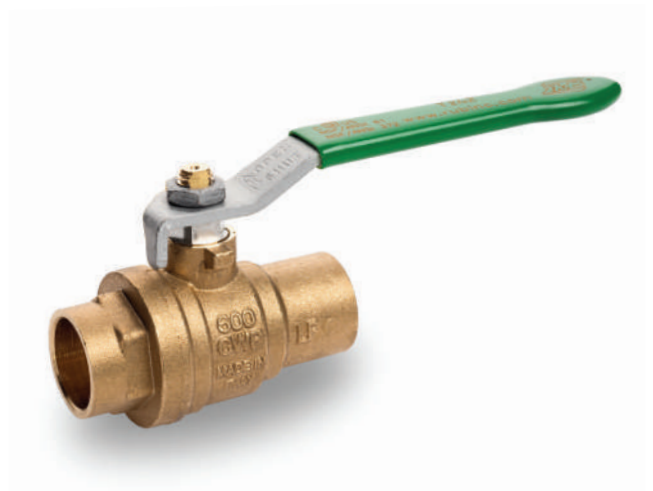

QUALITY

- Certified by CSA International to comply with U.S. s3874, California AB1953, and similar laws of other states for the safe handling of drinking water
- 24h 100% seal test guaranteed
- Dual sealing system allows valve to be operated in either direction making installation easier
- No metal-to-metal moving parts
- Handle clearly shows ball position
- Silicone-free lubricant on all seals
- Chrome plated lead free brass ball for longer life
- Handle stops on body to avoid stresses at stem

BODY

- Hot forged sand blasted, unplated lead free brass body and cap sealed with Loctite® or equivalent thread sealant

STEM

- Pure PTFE adjustable packing gland and reinforced PTFE washer for lower torque and easy maintenance
- Blowout-proof unplated lead free brass stem

SEALING

- Pure PTFE self-lubricating seats with flexible-lip design

CONNECTIONS

- Solder-end ANSI B16.18 female by female connections

FLOW

- Full port to DIN 3357 for maximum flow

HANDLE

- Geomet® carbon steel handle with thick PVC dip coating. Handle coating offers both thermal and electrical protection
- **WARNING:** do not exceed reasonable temperature and/or electrical load

WORKING PRESSURE & TEMPERATURE

- 600 PSI (for solder joints rating see table 1) non-shock cold working pressure
- For general use: -4°F / +350°F (for solder joints rating see table 1)
- NSF 61 limits (CSA approval): tested for use in continuous exposure to water of ambient temperature
- **WARNING:** freezing of the fluid in the installation may severely damage the valve

UPON REQUEST

- Glass filled PTFE seals
- Stainless steel handle (1.4016 / AISI 430)
- Custom design
- * For sales within EU: CE marking needed, please contact us

APPROVED BY OR IN COMPLIANCE WITH

- EAC – Declaration of conformity (Russia, Kazakhstan, Belarus)
- Certified by CSA International for Drinking Water to NSF/ANSI 61 – NSF/ANSI 372 (United States)
- RoHS Compliant (EU)

NOTE: approvals apply to specific configurations/sizes only.

OPTIONS

- Oval lockable handle ①
- Patented locking device ②
- Stem extension (assemble after soldering)
- Stubby handle ③
- T-handle ④



PURI-T 242 XGET242 - 6012

Each user should perform his own tests to find out the suitability for his particular application. BONOMI INDUSTRIES makes no warranty, express or implied, as to the shape, fit or function of a product for any application. Contact us or consult with your supplier for additional information on the suitability of the BONOMI INDUSTRIES products with your specific field of use.



Part description		Q.ty	Material
1	Unplated solder end body	1	CW510L
2	Seat	2	PTFE
3	Chrome plated ball	1	CW510L
4	Unplated solder end-cap	1	CW510L
5	Unplated stem packing gland design	1	CW510L
6	Nickel plated gland nut	1	CW617N
7	Geomet® nut	1	CB4FF (EN10263-2)
8	Packing gland seal	1	PTFE
9	Thrust washer	1	PTFE carbon filled 25%
10	Green PVC coated Geomet® steel handle	1	DD11 (EN10111)

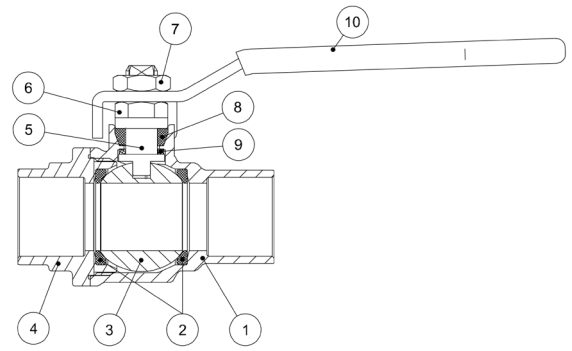

1 ½"-2" hollow ball

For sales within EU: CE marking needed, please contact us

Code		T242D00	T242E00	T242F00	T242G00	T242H00	T242I00
D (inch)	Nominal	1/2"	3/4"	1"	1 ¼"	1 ½"	2"
	Actual	0,6271	0,8771	1,1279	1,3779	1,6279	2,1279
DN (inch)		0,551	0,748	0,944	1,181	1,496	1,889
I (inch)		0,492	0,748	0,905	0,964	1,102	1,338
L (inch)		2,244	2,854	3,346	3,819	4,488	5,433
G (inch)		1,181	1,476	1,673	1,909	2,244	2,716
A (inch)		3,937	4,724	4,724	6,22	6,22	6,22
H (inch)		1,693	1,968	2,165	2,992	3,228	3,504
Cv (GPM)		32,3	48,5	80,9	127,1	144,4	206,8

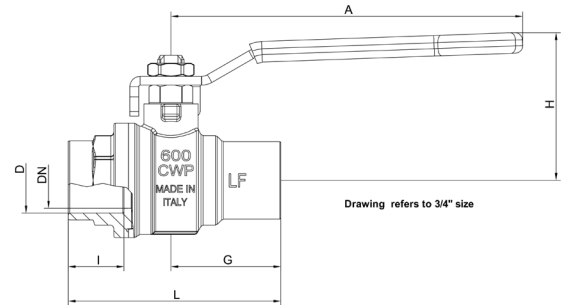

DN shows the nominal flow diameter. Actual flow diameter complies with full port DIN 3357 part 4.

TABLE 1 PRESSURE - TEMPERATURE RATINGS

Joining material	Melting range degrees		Working temperature degrees		Maximum working gauge pressure					
					Size 1/8" - 1"		Size 1 ¼" - 2"		Size 2 ½" - 4"	
	°F	°C	°F	°C	PSI	kPa	PSI	kPa	PSI	kPa
50-50 tin-lead solder* ASTM B32 alloy grade 50 A	361/421	185/215	0/+100	-18/+38	200	1400	176	1200	150	1050
			0/+150	-18/+66	150	1050	125	850	100	700
			0/+200	-18/+93	100	700	90	600	75	500
			0/+250	-18/+121	85	600	75	500	50	350
95-5 tin-antimony solder ASTM B32 alloy grade 95TA	450/464	230/240	0/+100	-18/+38	500**	3500**	400**	2800**	300**	2100**
			0/+150	-18/+66	400**	2800**	350**	2400**	275**	2000**
			0/+200	-18/+93	300**	2100**	250**	1700**	200	1400
			0/+250	-18/+121	200	1400	175	1200	150	1050

Note:

Above stated limits are not imposed by the valve, but by the strength of the soldering joint according to ASME B16.22. * This alloy contains more than 0,2% lead and, according to certain specifications, cannot be used for potable water or other foods. ** Soldered copper tube joints have been tested at 230 PSI (1600 kPa) in accordance with ISO 2016

PRESSURE-TEMPERATURE CHART

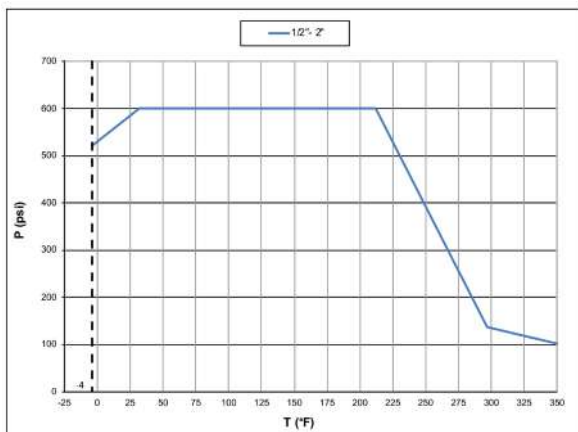

PRESSURE DROP CHART

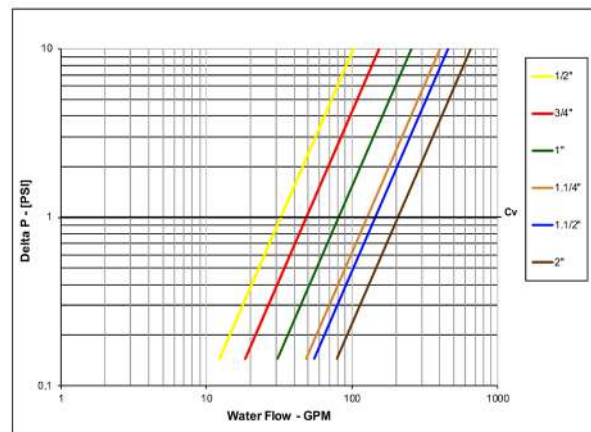

Chart applies to valve, not to solder joints for general use
BONOMI INDUSTRIES SRL - www.rubvalves.com



Puri-T 264 NPT

Female/Female
1/2" - 1 1/2"
Lead Free, ISO 5211

All surfaces of this product in contact with drinking water contain less than 0.25% of lead in compliance with U.S. law



QUALITY

- Certified by CSA International to comply with U.S. s3874, California AB1953, and similar laws of other states for the safe handling of drinking water
- 24h 100% seal test guaranteed
- Dual sealing system allows valve to be operated in either direction making installation easier
- No metal-to-metal moving parts
- No maintenance ever required
- Silicone-free lubricant on all seals
- Chrome plated lead free brass ball for longer life

BODY

- Hot forged sand blasted, unplated lead free brass body and cap sealed with Loctite® or equivalent thread sealant
- Integrated ISO 5211 and DIN 3337 mounting flange for universal connection to actuator
- Finest brass according to EN 12165 and EN 12164 specifications

STEM

- Blowout-proof nickel plated lead free brass stem
- Maintenance-free, double FPM O-rings at the stem for maximum safety

SEALING

- Reinforced PTFE self-lubricating seats with flexible-lip and wear compensation design

THREADS

- NPT taper ANSI B.1.20.1 female by female threads

FLOW

- 100% full port for maximum flow

OPERATING MECHANISM

- Integrated sturdy ISO 5211 flange allows direct mounting of electric and pneumatic actuators, with no bracket or coupling required. See **RuB** line of electric and pneumatic actuators.

WORKING PRESSURE & TEMPERATURE

- 600 PSI up to 3/4" size
- For 1" size up to 1 1/2" size:
- Shell rating: 600 PSI
- Seat rating: Delta P max permissible 230 PSI
- non-shock cold working pressure
- For general use: -4°F/+350°F
- NSF 61 limits (CSA approval): tested for use in continuous exposure to water of ambient temperature
- **WARNING:** freezing of the fluid in the installation may severely damage the valve

UPON REQUEST

- Custom design
- * For sales within EU: CE marking needed, please contact us

APPROVED BY OR IN COMPLIANCE WITH

- EAC – Declaration of conformity (Russia, Kazakhstan, Belarus)
- Certified by CSA International for Drinking Water to NSF/ANSI 61 – NSF/ANSI 372 (United States)
- RoHS Compliant (EU)

NOTE: approvals apply to specific configurations/sizes only.

OPTIONS

- Rack and pinion pneumatic actuator (spring return or double acting)
- Compact power electric actuator for some sizes
- Manual lockable handle



PURI-T 264 XCET264 - 6012

Each user should perform his own tests to find out the suitability for his particular application. BONOMI INDUSTRIES makes no warranty, express or implied, as to the shape, fit or function of a product for any application. Contact us or consult with your supplier for additional information on the suitability of the BONOMI INDUSTRIES products with your specific field of use.



Part description		Q.ty	Material
1	Unplated NPT body	1	CW510L
2	Ball seat	2	PTFE graphite filled 15%
3	Chrome plated ball	1	CW510L
4	Unplated NPT end-cap	1	CW510L
5	Washer	1	PTFE carbon filled 25%
6	Nickel plated stem O-ring design	1	CW510L
7	O-Ring	2	FPM
8	O-Ring	2	FPM

For sales within EU: CE marking needed, please contact us

Code	T264D41	T264E41	T264F41	T264G41	T264H41
D (inch)	1/2"	3/4"	1"	1 1/4"	1 1/2"
DN (inch)	0,59	0,787	0,984	1,259	1,575
I (inch)	0,61	0,708	0,827	0,905	0,964
L (inch)	2,598	2,933	3,563	4,094	4,606
G (inch)	1,201	1,457	1,791	2,047	2,322
H (inch)	1,22	1,516	1,673	1,941	2,441
CH (inch)	1,063	1,260	1,614	1,968	2,165
ØA (inch)	1,417	1,417	1,417	1,417	1,968
□B (inch)	0,354	0,354	0,354	0,354	0,551
C (inch)	0,22	0,22	0,22	0,22	0,260
E (inch)	0,984	0,984	0,984	0,984	1,378
F (inch)	0,295	0,335	0,335	0,335	0,571
Flange connection	F03	F03	F03	F03	F05
Cv (GPM)	32,3	69,3	115,5	179,1	283,1

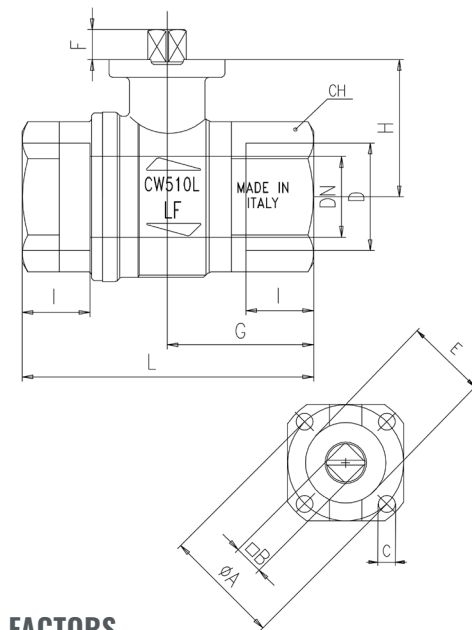
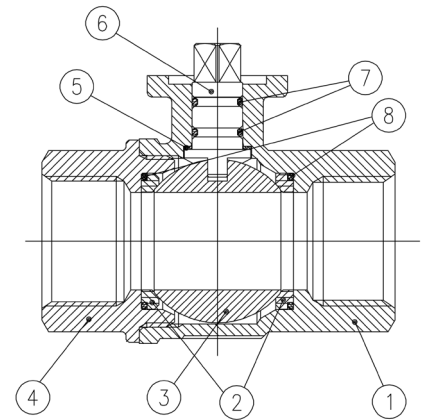

TORQUE FOR ACTUATOR SIZING IN-LB

Delta P →	0÷200 PSI		600 PSI	
	to open	to close	to open	to close
1/2"	25	15	25	15
3/4"	33	20	33	20

Delta P →	0÷90 PSI		>90÷230 PSI	
	to open	to close	to open	to close
1"	19	19	31	31
1 1/4"	22	22	35	35
1 1/2"	51	51	84	84

PRESSURE-TEMPERATURE CHART

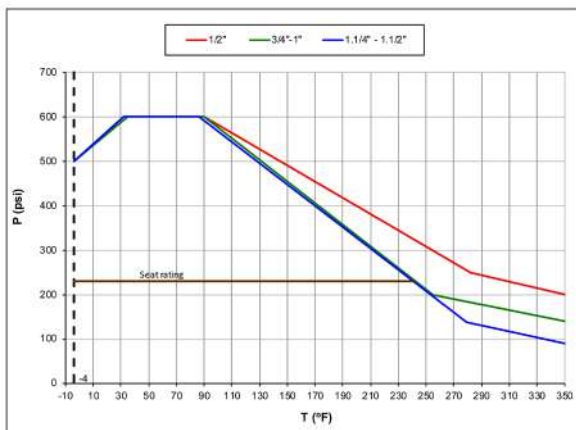

TORQUE CORRECTION FACTORS

Valve torque can vary according to operating frequency, temperature and friction characteristics of the media. If media has more or less friction than water, multiply torque by the following factors:

Lubricating oils or liquids	0.8
Dry gases, natural gas	1.5
Slurries or liquids bearing abrasive particles	1.5÷2.5

PRESSURE DROP CHART

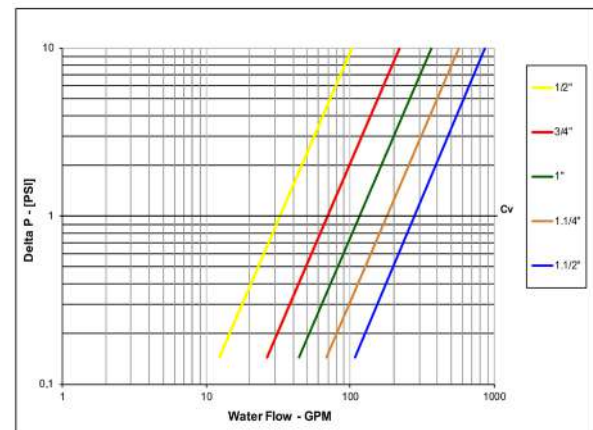



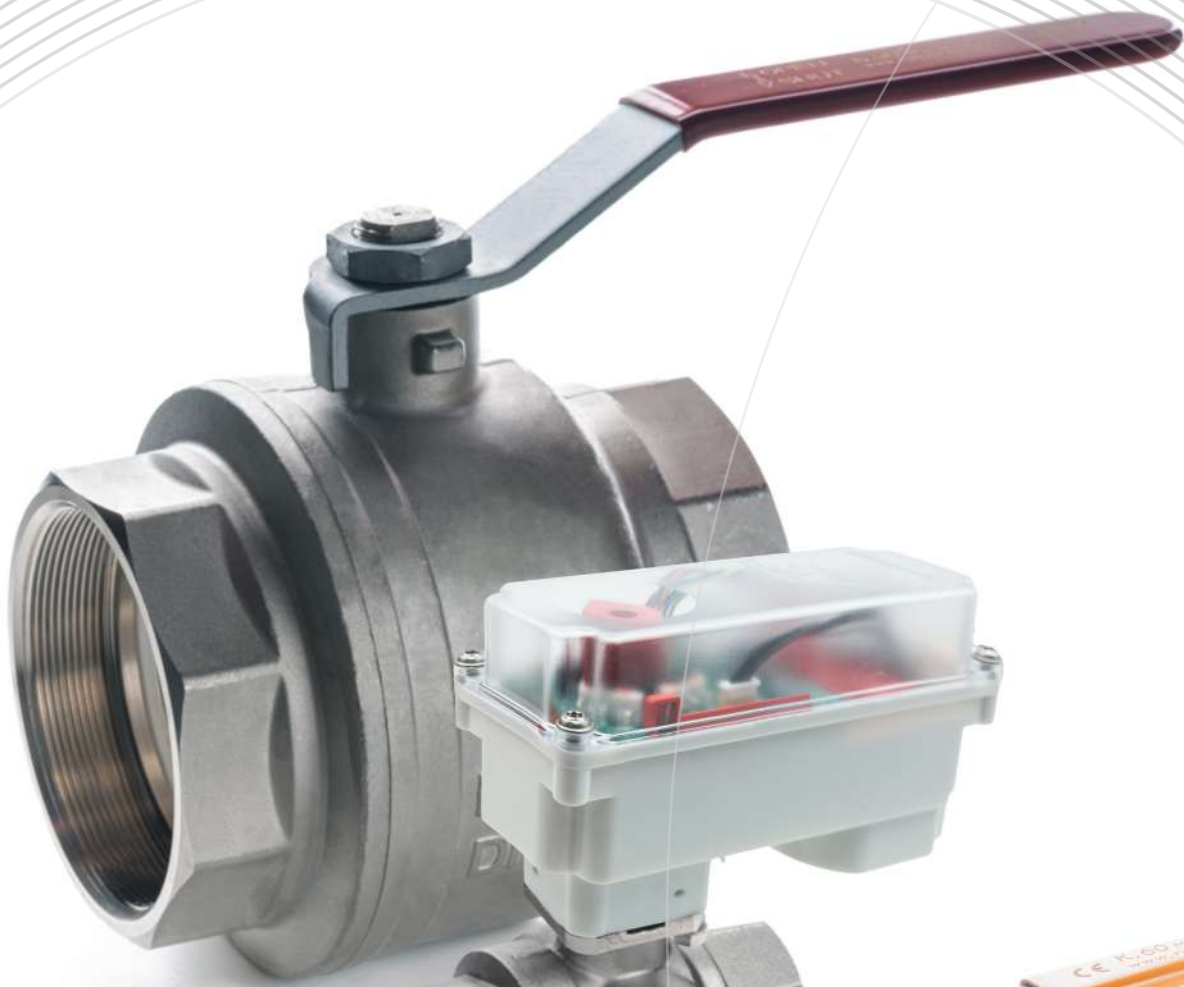

Application Catalog



ACTUATION



INDUSTRY



PNEUMATIC



GAS



FIREFIGHTING



DRINKING WATER



PLUMBING



ACCESSORIES



Ask for additional information on the whole range of **RuB** products and consult with your supplier for special applications.



ALL RIGHTS RESERVED | COPYRIGHT© Bonomi Industries Srl 2026

Bonomi Industries Srl endeavors to provide comprehensive information about the installation, maintenance and operation of its products. For more details or clarification, please contact us. **Bonomi Industries Srl** reserves the right to change or modify product design, construction, specifications, materials or the information herein without prior notice and without incurring any obligation to make such changes and modifications on products previously or subsequently sold. Content of this document is proprietary to **Bonomi Industries Srl** and it may not be copied in part or in whole without prior written authorization. Recommendations on application design and material selection are based on available technical data and are offered as suggestions only. Each user should make his/her own tests to determine the suitability for his/her own particular use. **Bonomi Industries Srl** gives no express or implied warranties concerning the form, fit, or function of a product in any application. **Bonomi Industries Srl** does not accept liability for errors or omissions. Any undated reference to a code or standard shall be interpreted as referring to the latest edition.

Bonomi Industries Srl, **RuB** and triangles, are all registered trademarks of **Bonomi Industries Srl**. Other logos or trademarks are property of respective owners.





Via Padana Superiore, 29, 25080 Mazzano (BS), Italy
Tel.: +39 030 212441 - sales@rubvalves.com
www.rubvalves.com