



s.20 DZR M/F

3/8" - 1 1/4"

ISO 228

dezincification-resistant



Several governmental authorities recommend use of special alloys for valves handling water in areas where there is a problem of dezincification. **RuB** DZR valves are designed to meet such requirements.

Through the use of new technology these valves retain the reliability and competitiveness of brass, but are comparable to bronze in corrosion resistance.

Be kind with yourself, make sure the valve that brings you pure fresh water is an **RuB** DZR valve.



Quality

- 24h 100% seal test guaranteed
- Dual sealing system allows valve to be operated in either direction making installation easier
- No metal-to-metal moving parts
- No maintenance ever required
- Handle clearly shows ball position
- Silicone-free lubricant on all seals
- Chrome plated DZR brass ball for longer life
- Handle stops on body to avoid stress at stem

Body

- Hot forged sand blasted DZR unplated body and cap sealed with Loctite® or equivalent thread sealant
- Dezincification resistant ADZ-T and ADZ-P brass approved to SBN-PFS 1983:2 and NR-BFS 1988:18 specifications

Stem

- Maintenance-free, double FPM O-rings at the stem for maximum safety
- Blowout-proof unplated DZR brass stem

Sealing

- Pure PTFE self-lubricating seats with flexible-lip design

Threads

- ISO 228 parallel male by female threads

Flow

- Full port to DIN 3357 for maximum flow

Handle

- Geomet® carbon steel handle with thick PVC dip coating. Handle coating offers both thermal and electrical protection
- Handle removable with valve in service
- **WARNING:** do not exceed reasonable temperature and/or electrical load

Working pressure & temperature

- 30 bar (450 PSI) non-shock cold working pressure
- -40°C to +170°C (-40°F to +350°F)
- **WARNING:** freezing of the fluid in the installation may severely damage the valve

Options

- CW617N brass body and components
- T-handle
- Oval lockable handle
- Stainless steel handle (1.4016 / AISI 430)
- Patented locking device
- Brass stem extension
- Female by female threads for sizes 1/4" through 2"
- Stubby handle
- **RuB** memory stop designed to be installed with our stubby handle

Upon request

- Stainless steel ball (1.4401 / AISI 316)
- Glass filled PTFE seals
- Custom design

PED directive

- According to 2014/68/UE module A: it cannot be used with dangerous gases in sizes larger than 25mm

Approved by or in compliance with

- RoHS Compliant (EU)
- GOST-R (Russia)
- EAC – Declaration of conformity (Russia, Kazakhstan, Belarus)
- KIWA Regulation 4 a.k.a. KUKreg4 (United Kingdom)

NOTE: approvals apply to specific configurations/sizes only.



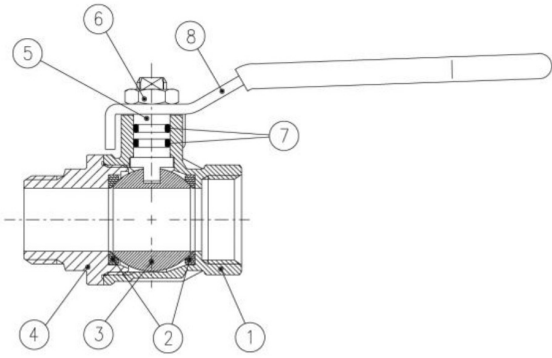

Part description	Q.ty	Material
1	1	CW602N
2	2	PTFE
3	1	CW602N
4	1	CW602N
5	1	CW602N
6	1	CB4FF (EN10263-2)
7	2	FPM
8	1	DD11 (EN10111)

1 1/4" hollow ball

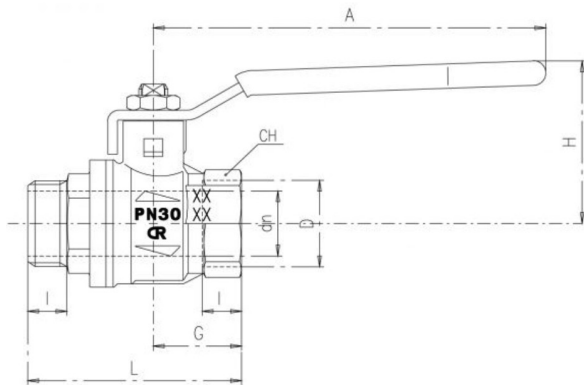

DN shows the nominal flow diameter. Actual flow diameter complies with full port DIN 3357 part 4

Code	S20C20	S20D20	S20E20	S20F20	S20G20
D (inch)	3/8	1/2	3/4	1	1 1/4
DN (mm)	10	15	20	25	32
I (mm)	9	11	12	14	15
L (mm)	49	60	65.5	77.5	89
G (mm)	19.5	25	27	33.5	38.5
A (mm)	82	100	120	120	158
H (mm)	38	43	50	54	73
CH (mm)	20	25	31	38	48
Kv (m3/h)	8.2	28	42	70	80

Pressure-temperature chart

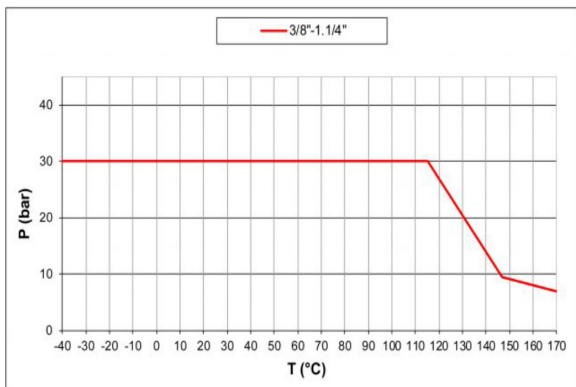

Pressure drop chart

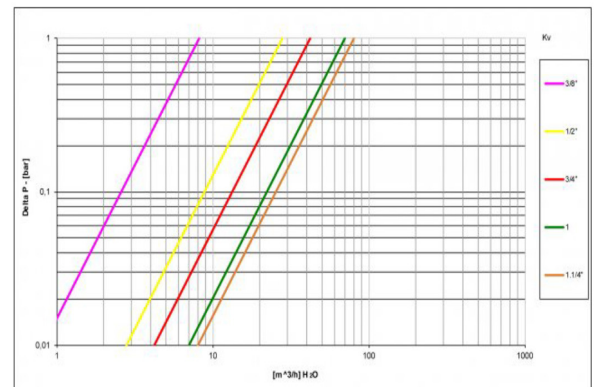

XCES20M - 5202