



s.7650 BSPT

3-way 2 seats L-port (diverting)

1/2" - 2"
ISO 5211

The **RuB** s.7650 is the right choice for fluid diversion and is designed with robust maintenance-free components ensuring ease of operation and safety. With a simple 90° turn, you can divert flow from one downstream outlet to the other. It combines traditional manual operation with modern automation. It is also very easy to convert from its sturdy lever handle to ISO 5211 actuator flange assembly. It features low operating torque and a special wear reducing self-compensating valve seat design that meets our 100,000 cycle life test requirement. The valve can be purchased separately, with handle or with a **RuB** actuator already mounted.



Quality

- Electronic 100% seal test guaranteed
- No metal-to-metal moving parts
- No maintenance ever required
- Silicone-free lubricant on all seals
- Chrome plated brass ball for longer life
- Each valve is seal tested for maximum safety
- Performs well in any orientation
- Strong configuration

Body

- Hot forged sand blasted, external nickel plated brass body and cap sealed with Loctite® or equivalent thread sealant
- Integrated ISO5211 / DIN3337 mounting flange for universal connection to actuator
- Finest brass according to EN 12165 and EN 12164 specifications
- 3-way L-port design for flow diversion

Stem

- Blowout-proof nickel plated brass stem
- Maintenance-free, double O-rings at the stem for maximum safety
- Stem slot shows ball position

Sealing

- Reinforced PTFE self-lubricating seats with flexible-lip and wear compensation design

Threads

- ISO 7/1, BS 21 BSPT taper female threads

Flow

- 100% full port for maximum flow

Handle

- Integrated sturdy ISO 5211 flange allows direct mounting of actuators. See **RuB** line of electric and pneumatic actuators.

Working pressure & temperature

- 30 Bar up to 1", 20 bar over 1", non-shock cold working pressure
- -20°C to +170°C (-4°F to +350°F)
- **WARNING:** freezing of the fluid in the installation may severely damage the valve

Options

- Rack and pinion pneumatic actuator (spring return or double acting)
- Compact Power electric actuator
- EN10226-1/ISO228 female threads
- Female by female NPT threads
- Lockable handle as accessory or already mounted (s.7650L)
- Various actuator linkage kit

Upon request

- Custom design
- Stainless steel stem
- Configurations with 4 seats, T-port (s.7350)

PED directive

- The product meets the requirements of PED Directive 2014/68/UE and according to art.4 par.3, it does not require CE marking.

Approved by or in compliance with

- RoHS Compliant (EU)

NOTE: approvals apply to specific configurations/sizes only.



S.76 3-way "L" port operating positions

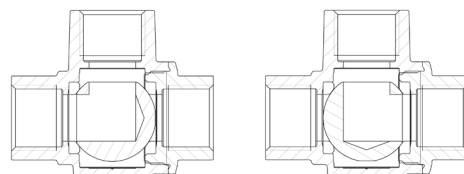

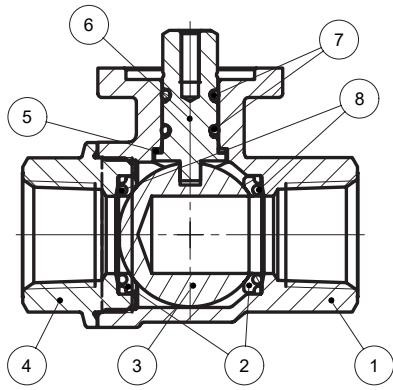

	Part description	Q.ty	Material
1	Sand blasted nickel plated BSPT body (external nickel plated, unplated inside)	1	CW617N
2	Seat	2	PTFE graphite filled 15%, PTFE over 1"
3	Chrome plated ball	1	CW617N
4	Sand blasted nickel plated BSPT end-cap (external nickel plated, unplated inside)	1	CW617N
5	Washer	1	PTFE carbon filled 25%
6	Nickel plated stem O-ring design	1	CW617N
7	O-Ring	2	FPM
8	O-Ring	2	FPM

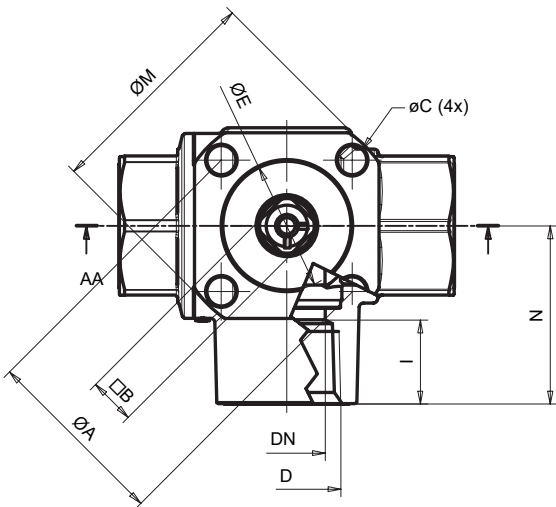
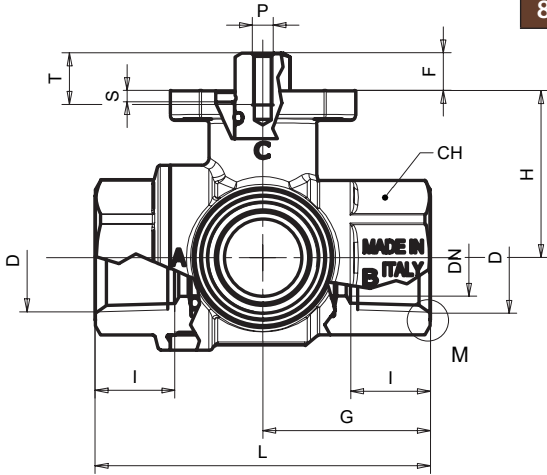

Code	S76D50	S76E50	S76F50	S76G50	S76H50	S76I50
D (inch)	1/2"	3/4"	1"	1 1/4"	1 1/2"	2"
DN (mm)	15	20	25	30.4	38	48
I (mm)	16.5	19	22.5	23	24.5	26.5
L (mm)	65	79	92.5	109.5	126	150
G (mm)	32.5	39.5	46.5	55	63	75
H (mm)	32.5	39.5	42.5	56	63.2	72
N (mm)	34.5	42	49.5	60	69	82
ØA (mm)	36	36	36	50	50	50
ØC (mm)	Ø5.6	Ø5.6	Ø5.6	Ø6.6	Ø6.6	Ø6.6
ØE (mm)	25	25	25	35	35	35
Square B (mm)	9	9	9	11	11	14
ØM (mm)	43.4	43.4	43.4	60.8	60.8	60.8
S (mm)	2.2	2.2	2.2	3.2	3.2	3.2
T (mm)	10	10	10	14	14	14
F (mm)	7.3	8.3	8.3	10	10	14.5
CH (mm)	27	32	41	50	55	70
Flange connection DIN ISO 5211-DIN 3337	F03	F03	F03	F05	F05	F05
P (ISO 262 Thread)	M4	M4	M4	M5	M5	M5

Torque for actuator sizing N.m

Delta P -->	0÷16 bar	
	to open	to close
Valve size		
1/2"	3,5	3,5
3/4"	4,0	4,0
1"	4,5	4,5
1 1/4"	11,7	11,7
1 1/2"	21,5	21,5
2"	28,0	28,0

Torque correction factors

Valve torque can vary according to operating frequency, temperature and friction characteristics of the media.

If media has more or less friction than water, multiply torque by the following factors:

Lubricating oils or liquids	0.8
Dry gases, natural gas	1.5
Slurries or liquids bearing abrasive particles	1.5÷2.5

Pressure drop chart

