



s.8042 NPT

3/4" - 2" MIP x FIP, with tamper proof lockwing



Quality

- 24h 100% seal test guaranteed
- Dual sealing system allows valve to be operated in either direction making installation easier
- No metal-to-metal moving parts
- No maintenance ever required
- Cover clearly shows ball position
- Silicone-free lubricant on all seals
- Chrome plated brass ball for longer life
- Handle stops on body to avoid stresses at stem

Body

- Hot forged sand blasted, unplated brass body and cap sealed with Loctite® or equivalent thread sealant
- Special design to combine newest technologies in valve and traditional gas-cock requirements
- Finest brass according to EN 12165 and EN 12164 specifications

Stem

- Blowout-proof unplated brass stem
- Maintenance - free, double FPM O-rings at the stem for maximum safety

Sealing

- Pure PTFE self-lubricating seats with flexible-lip design

Threads

- NPT taper ANSI B.1.20.1 male by female threads

Flow

- Full port to DIN 3357 for maximum flow

Handle

- Hot forged brass tamper proof lockwing

Working pressure & temperature

- 600 PSI (40 bar) non-shock cold working pressure
- 250 PSI (17 bar) non-shock working pressure for LP-Gas
- -40°F to +350°F (-40°C to +170°C)
- **WARNING:** freezing of the fluid in the installation may severely damage the valve

Options

- Female by female NPT threads

Approved by or in compliance with

- Canadian standards Association (United States, Canada)
- GOST-R (Russia)
- RoHS Compliant (EU)
- Underwriters Laboratories (United States, Canada):
 - Guide YSDT: LP-Gas shut-off valve
 - Guide YRBX: Flammable liquid shut-off valve
 - Guide YRPV: Gas shut-off valve for use with natural and manufactured gases
 - Guide MHKZ: No. 6 oil at 250°F

NOTE: approvals apply to specific configurations/sizes only.

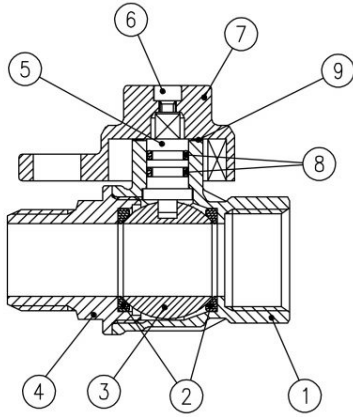

PART DESCRIPTION	Q.TY	MATERIAL
1 Unplated NPT body	1	CW617N
2 Seat	2	PTFE
3 Chrome plated ball	1	CW617N
4 Unplated NPT male end-cap	1	CW617N
5 Unplated stem O-ring design	1	CW617N
6 Stainless steel screw	1	1.4301 / AISI 304
7 Unplated lockwing	1	CW617N
8 O-Ring	2	FPM
9 Washer (from 3/4" to 2")	1	PTFE glass filled 25%

1.1/4"- 2" hollow ball

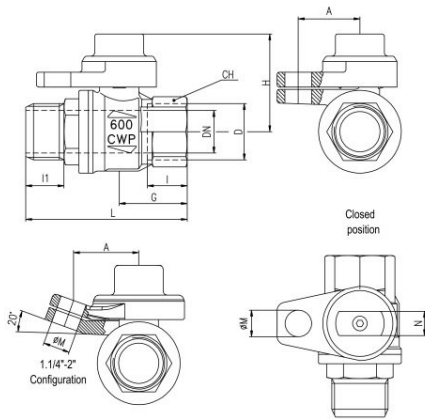

Code	S80E42	S80F42	S80G42	S80H42	S80I42
D (inch)	3/4	1	1 1/4	1 1/2	2
DN (inch)	0.787	0.984	1.259	1.574	1.968
I (inch)	0.669	0.826	0.905	0.905	1.043
I1 (inch)	0.709	0.866	0.945	0.945	1.083
L (inch)	2.992	3.642	4.173	4.449	5.236
G (inch)	1.259	1.594	1.830	2.007	2.381
A (inch)	1.142	1.142	1.208	1.208	1.208
H (inch)	1.801	1.958	2.519	2.756	3.031
M (inch)	0.492	0.492	0.472	0.472	0.472
N (inch)	0.449	0.449	0.563	0.563	0.563
CH (inch)	1.220	1.574	1.929	2.125	2.696
Cv (GPM)	48.5	80.9	92.4	144.4	206.8

DN shows the nominal flow diameter. Actual flow diameter complies with full port DIN 3357 part 4.

Pressure-temperature chart

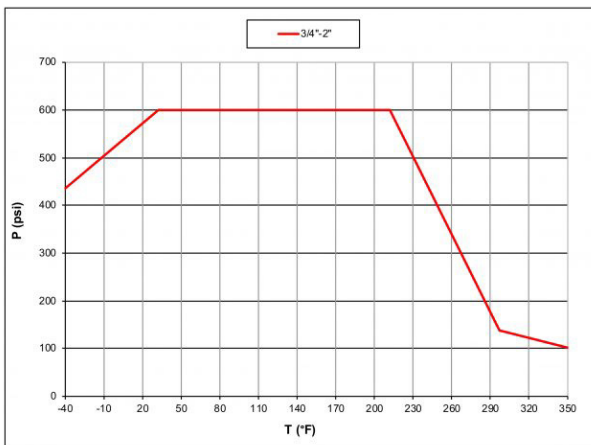

Pressure drop chart

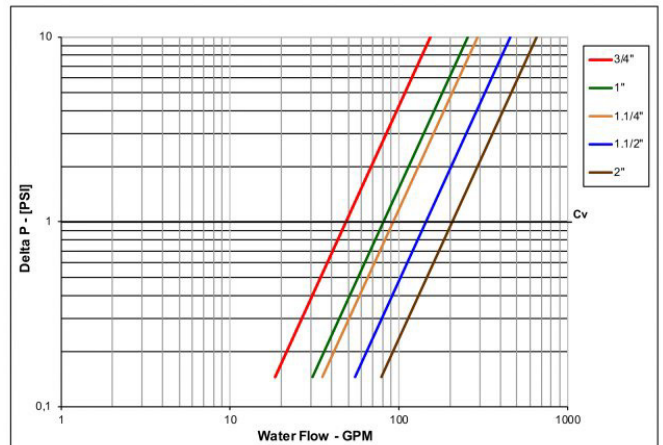

Ask for additional information on the whole range of **RuB** products and consult with your supplier for special applications.
For complete disclaimer: www.rubvalves.com/disclaimer