



# s.17

## motor-oil drain ball valve

Specifically responding to a need in the automotive application, s.17 is fitted under the oil sump to ease drainage operations, and furthermore granting a most reliable tightness thanks to its special automatic locking device, even under severe conditions of vibration stress.

Frozen drain plug and stripped threads are eliminated, no more contact with hot oil, no messy hands or cloths and reduced oil changing time.



### Quality

- 24h 100% seal test guaranteed
- No metal-to-metal moving parts
- No maintenance ever required
- Handle clearly shows ball position
- Silicone-free lubricant on all seals
- Dual sealing system to prevent leakage
- Handle stops on body to avoid stresses at stem

### Body

- Hot forged sand blasted, unplated brass body and cap sealed with Loctite® or equivalent thread sealant
- Compact design and solid structure
- Fines brass according to EN 12165 and EN 12164 to prevent corrosion

### Stem

- Blowout-proof unplated brass stem
- Maintenance-free, double FPM O-ring at the stem for maximum safety

### Sealing

- Glass filled pure PTFE self-lubricating seats with flexible-lip design

### Threads

- M24x1.5 – 3/8" threads

### Handle

- Tamper proof and sealed to prevent dirt or dust from entering the rotation mechanism
- 90° opening rotation
- Automatic lock in closed position, to prevent accidental opening and thus warrant utmost safety

### Working pressure & temperature

- 20 bar (300 PSI) non-shock cold working pressure
- -20°C to +130°C (-4°F to +266°F)
- **WARNING:** freezing of the fluid in the installation may severely damage the valve

### Options

- M16x1.5 threads – hose connection
- M12x1.5 threads – hose connection
- M24x1.5 – 1/4" threads

### Upon request

- Stainless steel ball (1.4401 / AISI 316)
- Custom design

### PED directive

- The product meets the requirements of PED Directive 2014/68/UE and according to art.4 par.3, it does not require CE marking

### Approved by or in compliance with

- GOST-R (Russia)
- RoHS Compliant (EU)

**NOTE:** approvals apply to specific configurations/sizes only.

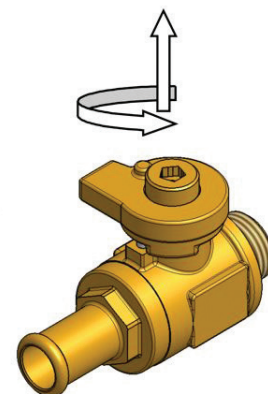

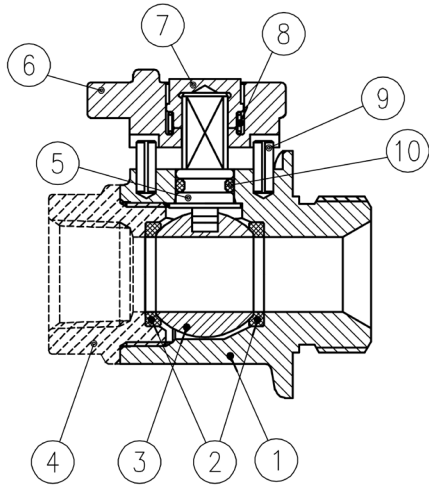

	Part description	Q.ty	Material
1	Unplated sand blasted body	1	CW617N
2	Seat	2	PTFE glass filled 5-15%
3	Chrome plated ball	1	CW617N
4	Unplated end-cap - hose connection - custom	1	CW617N
5	Unplated stem O-ring design	1	CW617N
6	Unplated sand blasted handle	1	CW617N
7	Unplated handle cap	1	CW617N
8	Spring	1	X10CrNi 18-8
9	Spring pin Ø 3x8 ISO 8752	2	X10CrNi 18-8
10	O-Ring	1	FPM

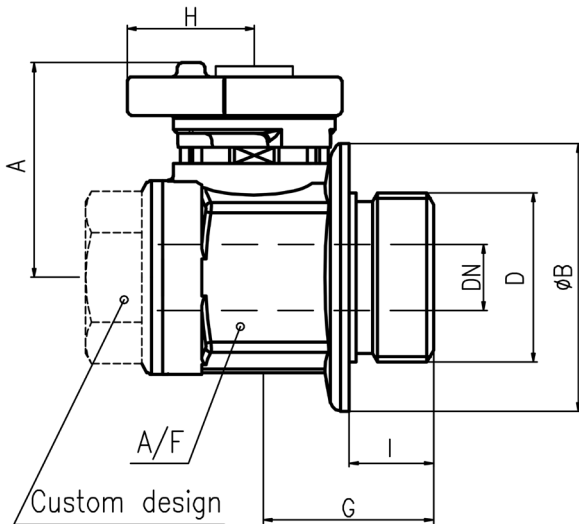

	M12x1.5	M16x1.5	M24x1.5
D (mm)	6	10	11.5
DN (mm)	10	10	12
I (mm)	27	27	38
øB (mm)	24.5	24.5	25.5
G (mm)	31.5	31.5	31.5
H (mm)	18	18	18
A/F (mm)	25	25	27
Kv (m3/h)	8.8		

**Pressure-temperature chart**

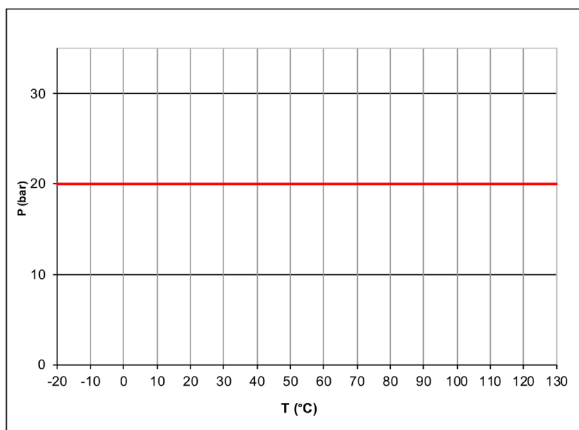

**Pressure drop chart**

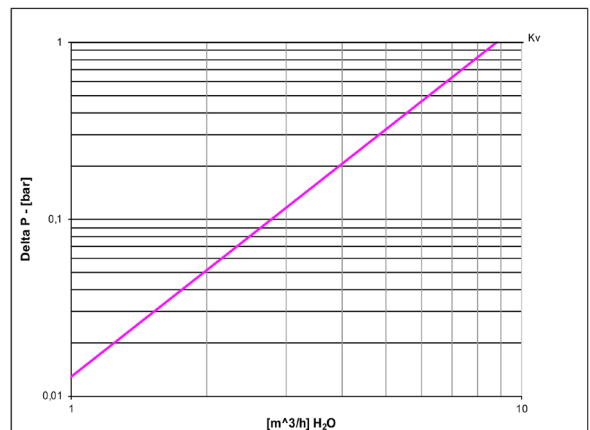

XCES17 - 4266