



s.172

motor-oil compact drain ball valve

Specifically responding to a need in the automotive application, s.172 is fitted under the oil sump to ease drainage operations, and furthermore granting a most reliable tightness thanks to its special automatic locking device, even under severe conditions of vibration stress.

Frozen drain plug and stripped threads are eliminated, no more contact with hot oil, no messy hands or cloths and reduced oil changing time.



PATENT PENDING



Quality

- 24h 100% seal test guaranteed
- No metal-to-metal moving parts
- No maintenance ever required
- Silicone-free lubricant on all seals
- Screwdriver slot, the slot orientation shows the ball position

Body

- Hot forged sand blasted, unplated brass body and cap sealed with metacrylate sealant
- Compact design and solid structure
- Finest brass according to EN 12165 and EN 12164 to prevent corrosion

Stem

- Blowout-proof AISI 316 stainless steel stem
- Maintenance-free, double FPM O-ring at the stem for maximum safety

Sealing

- Pure PTFE self-lubricating seats

Threads

- M22X1.5 thread with seat for O-ring seal



Handle

- 90° open / close

Working pressure & temperature

- 20 bar (300 PSI) non-shock cold working pressure
- -20°C to +130°C (-4°F to +266°F)
- **WARNING:** freezing of the fluid in the installation may severely damage the valve

Options

- Elbow version with hose connection
- Allen stem

Upon request

- AISI 316 stainless steel ball
- Custom design
- Aluminum body

PED directive

- The product meets the requirements of PED Directive 2014/68/UE and according to art.4 par.3, it does not require CE marking

Approved by or in compliance with

- GOST-R (Russia)
- RoHS Compliant (EU)

NOTE: approvals apply to specific configurations/sizes only.

STRAIGHT CONFIGURATION

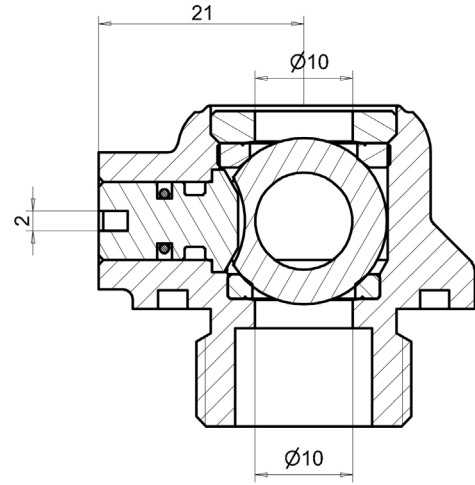
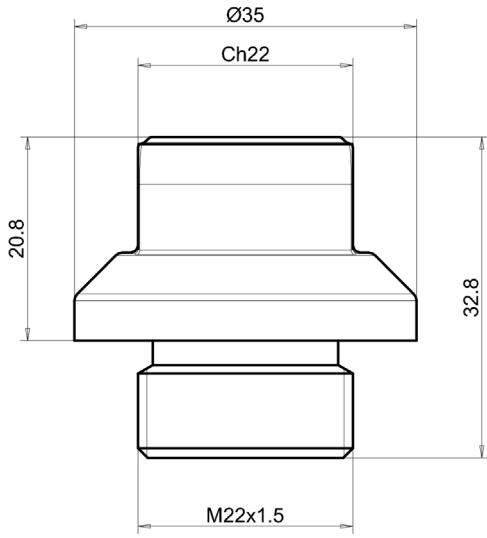

EXAMPLES OF VALVE DIMENSIONS AND CONFIGURATIONS

ELBOW CONFIGURATION

