



s.92S NPT solid ball

1/4" - 4"



Quality

- 24h 100% seal test guaranteed
- Dual sealing system allows valve to be operated in either direction making installation easier
- No metal-to-metal moving parts
- Handle clearly shows ball position
- Silicone-free lubricant on all seals
- Chrome plated brass solid ball for longer life
- Handle stops on body to avoid stress at stem

Body

- Hot forged sand blasted, unplated brass body and cap sealed with Loctite® or equivalent thread sealant
- Finest brass according to EN 12165 and EN 12164 specifications

Stem

- Blowout-proof nickel plated brass stem
- Pure PTFE adjustable packing gland and reinforced washer for lower torque and easy maintenance
- Triple stem seals in sizes over 2"

Sealing

- Glass filled pure PTFE self-lubricating seats with flexible-lip design

Threads

- NPT taper ANSI B. 1.20.1 female by female threads

Flow

- Full port to DIN 3357 for maximum flow
- Solid ball for optimum CV

Handle

- Geomet® carbon steel handle with thick PVC dip coating. Handle coating offers both thermal and electrical protection
- **WARNING:** do not exceed reasonable temperature and/or electrical load

Working pressure & temperature

- 600 PSI (40 bar) up to 2", 450 PSI (30 bar) over 2", (150 WSP / -10 bar all sizes) non-shock cold working pressure
- 250 PSI (17 bar) non-shock working pressure for LP-Gas
- *150 psig (10 bar) non-shock steam working pressure. Not suitable for throttling steam
- -40°F to +366°F (-40°C to +185°C)
- **WARNING:** freezing of the fluid in the installation may severely damage the valve

Options up to 2" size

- Stem extension
- T-handle
- Stainless steel handle (1.4016 / AISI 430)
- Oval lockable handle up to 2", round over 2"
- Patented locking device for valves up to 4"
- Male by female NPT threads up to 4"

Stubby handle

Upon request

- Stainless steel ball and/or stem (1.4401 / AISI 316)
- Custom design
- Pure PTFE seals

Approved by or in compliance with

- Canadian standards Association (United States, Canada)
- Factory Mutual (United States)
- RoHS Compliant (EU)
- GOST-R (Russia)
- Underwriters Laboratories (United States, Canada):
 - Guide YSDT: LP-Gas shut-off valve
 - Guide YRBX: Flammable liquid shut-off valve
 - Guide YRPV: Gas shut-off valve for use with natural and manufactured gases
 - Guide MHKZ: No. 6 oil at 250°F
- CRN-TSSA acc. to MSS SP110 (Canada)
- Kuwait Fire Service Directorate (Kuwait)
- Meeting WW-V-35C Federal U.S. Specification (United States)

NOTE: approvals apply to specific configurations/sizes only.



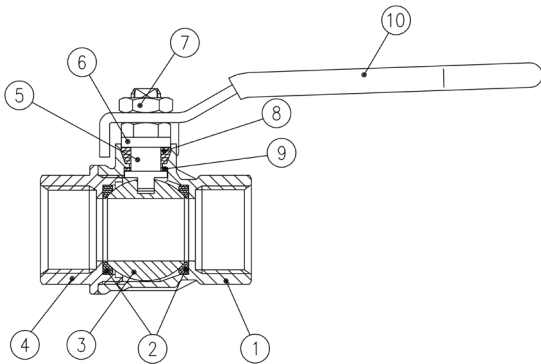

Part description	Q.ty	Material
1 Unplated NPT body	1	CW617N
2 Seat	2	PTFE glass filled 5-15%
3 Chrome plated solid ball	1	CW617N
4 Unplated NPT end-cap	1	CW617N
5 Nickel plated stem packing gland design	1	CW617N
6 Nickel plated gland nut	1	CW617N
7 Geomet® nut	1	CB4FF (EN10263-2)
8 Packing gland seal	1	PTFE
9 Washer	1	PTFE carbon filled 25%
10 Yellow PVC coated Geomet® steel handle	1	DD11 (EN10111)

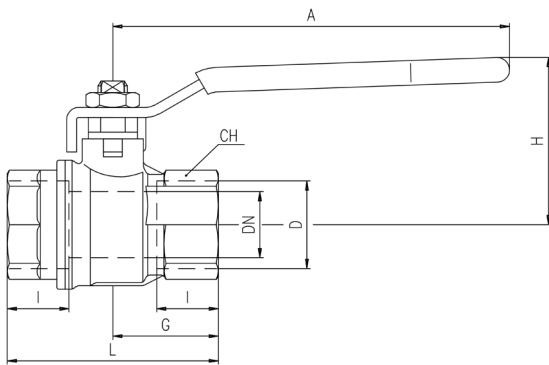

Code	S92B41	S92C41	S92D41	S92E41	S92F41	S92GP41	S92HP41	S92IP41	S92L41	S92M41	S92N41
D (inch)	1/4	3/8	1/2	3/4	1	1 1/4	1 1/2	2	2 1/2	3	4
DN (inch)	0.314	0.393	0.590	0.787	0.984	1.259	1.574	1.968	2.559	3.149	3.937
I (inch)	0.472	0.472	0.610	0.669	0.826	0.905	0.905	1.043	1.260	1.377	1.633
L (inch)	1.771	1.771	2.322	2.519	3.188	3.661	4.015	4.763	6.141	6.968	8.504
G (inch)	0.885	0.885	1.161	1.259	1.594	1.830	2.007	2.381	3.070	3.484	4.252
A (inch)	3.228	3.228	3.937	4.724	4.724	6.220	6.220	6.220	10.039	10.039	10.039
H (inch)	1.563	1.563	1.695	1.988	2.153	2.988	3.236	3.500	5.196	5.511	6.062
CH (inch)	0.669	0.787	0.984	1.220	1.574	1.929	2.125	2.696	3.346	3.897	4.921
Cv (GPM)	4.5	9.5	32.3	48.5	80.9	127.1	214.9	295.8	596.2	896.5	1305.5

DN shows the nominal flow diameter. Actual flow diameter complies with full port DIN 3357 part 4. Stem configuration of valves over 2" is slightly different.

Pressure-temperature chart

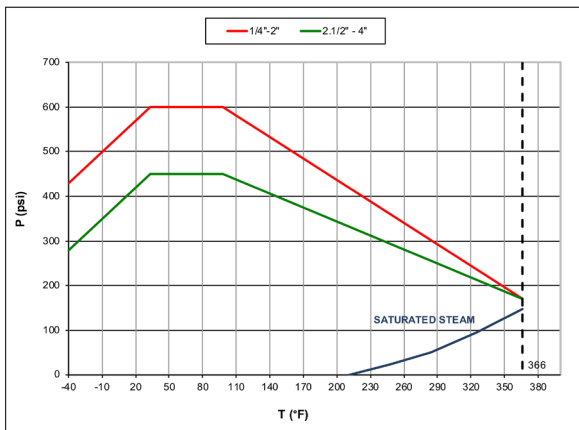

Pressure drop chart

