



## s.7300L 3-way, lever, 4 seats, T-port

1/2" - 1" EN 10226-1



The s.7300L series has a ball seal at every port, and offers a wide variety of possible flow configurations. Positive shutoff can be achieved at any of the exiting ports.

By specifying the appropriate ball port configuration, the T-port design allows flow direction to be adjusted for virtually any situation and is ideal for mixing applications.

Our s.73 multi-port valves can reduce the number of valves required in piping systems and can significantly lower overall costs by replacing two or three conventional 2-way valves, eliminating excess fittings, saving space and simplifying automation.



### Quality

- Electronic 100% seal test guaranteed
- No metal-to-metal moving parts
- No maintenance ever required
- Silicone-free lubricant on all seals
- Chrome plated brass ball for longer life
- Each valve is seal tested for maximum safety
- Performs well in any orientation
- Strong configuration

### Body

- Hot forged sand blasted, external nickel plated brass body and cap sealed with Loctite® or equivalent thread sealant
- Integrated ISO 5211 /DIN 3337 mounting flange for universal connection to actuator
- Finest brass according to EN 12165 and EN 12164 specifications
- 3-way T-port design for flow mixing

### Stem

- Blowout-proof nickel plated brass stem
- Maintenance-free, double FPM O-rings at the stem for maximum safety

### Sealing

- Pure PTFE self-lubricating seats with flexible-lip design
- Four seats design for mixing of various fluids in the system

### Threads

- EN 10226-1, ISO 228 parallel female threads



### Flow

- 100% full port for maximum flow

### Handle

- Geomet® carbon steel handle with thick PVC dip coating. Handle coating offers both thermal and electrical protection
- Handle removable with valve in service
- **WARNING:** do not exceed reasonable temperature and/or electrical load

### Working pressure & temperature

- 20 bar (300 PSI) non-shock cold working pressure
- -20°C to +150°C (-4°F to +302°F)
- **WARNING:** freezing of the fluid in the installation may severely damage the valve

### Options

- Rack and pinion pneumatic actuator (spring return or double acting)
- NPT threads ANSI B.1.20.1 female threads
- S.7300 without handle actuator ready
- Various actuator linkage kit

### Upon request

- Custom design
- Stainless steel stem
- Configurations with 4 seats & L-port (s.7200L) or 2 seats & L-port (s.7600L)

### PED directive

- The product meets the requirements of PED Directive 2014/68/UE and according to art.4 par.3, it does not require CE marking

### Approved by or in compliance with

- EAC - Declaration of conformity (Russia, Kazakhstan, Belarus)
- RoHS Compliant (EU)

**NOTE:** approvals apply to specific configurations/sizes only.

s73 3-way "T" port operating positions

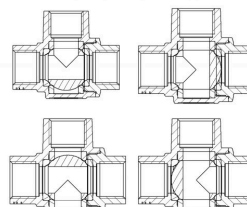

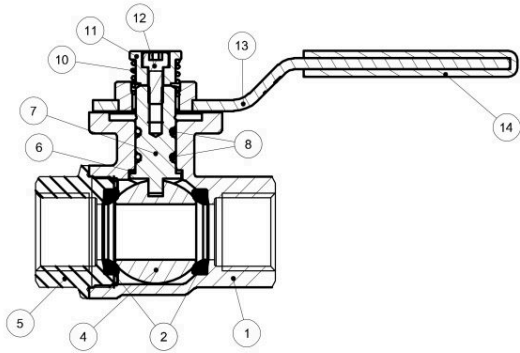

	PART DESCRIPTION	Q.TY	MATERIAL
1	Nickel plated body (external nickel plated, unplated inside)	1	CW617N
2	Seat	2	PTFE
3	Seat	2	PTFE
4	Chrome plated ball	1	CW617N
5	Nickel plated end-cap (external nickel plated, unplated inside)	1	CW617N
6	Washer	1	PTFE carbon filled 25%
7	Nickel plated stem O-ring design	1	CW617N
8	O-Ring	2	FPM
9	Screw handle stop	1	CW617N
10	Spring	1	1.4310 / AISI 302
11	Unplated spring bushing	1	CW617N
12	Stainless steel screw	1	1.4301 / AISI 304
13	Geomet® plated steel handle	1	DD11 (EN10111)
14	Black dipped coating	1	PVC

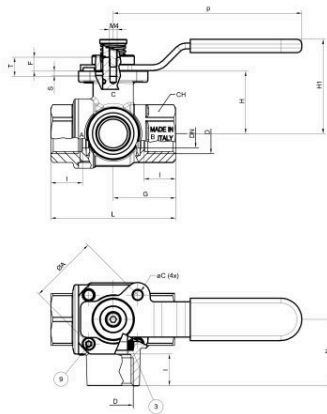

Code	S73D00L	S73E00L	S73F00L
D (inch)	1/2	3/4	1
DN(mm)	15	20	25
I (mm)	16.5	19	22.5
L (mm)	65	79	92.5
G (mm)	32.5	39.5	46.5
H (mm)	32.5	39.5	42.5
N (mm)	34.5	42	49.5
øA (mm)	36	36	36
øC (mm)	ø5.2 (M6)	ø5.2 (M6)	ø5.2 (M6)
p (mm)	100	100	100
H1 (mm)	49	56	59
S (mm)	2.2	2.2	2.2
T (mm)	10	10	10
F (mm)	7.3	8.3	8.3
CH (mm)	27	32	41
Flange connection ISO 5211 DIN3337	F03	F03	F03

### Torque for actuator sizing N.m

Delta P	0÷16 bar		
	Valve size	to open	to close
1/2"		10.5	10.5
3/4"		13	13
1"		29.5	29.5

### Torque correction factors

Valve torque can vary according to operating frequency, temperature and friction characteristics of the media.

If media has more or less friction than water, multiply torque by the following factors.

Lubricating oils or liquids	0.8
Dry gases, natural gas,	1.5
Slurries or liquids bearing abrasive particles	1.5+2.5

With the configuration of T-Ball a stop pin can be screwed in any position of the 4 provided in the flange (1, 2, 3 or 4) and the lever can be rotated freely through 90°, the flow assumes the directions indicated in the diagram; in case of need the lever can be pulled upwards and you can reach any of the four possible positions. An alternative is to mount 2 pins in 2 near holes (e.g. 1 and 2). In this case, the valve does not assume a predetermined position but can be actuated just by pulling the lever towards the top.

The valve allows also to block the lever thanks to the addition of a lock on the lever's protrusion (in the drawing you can see position 2).

The mixing configuration is achieved by placing the pin in position 2. The flows to be mixed enter through A and C and exit through A+C.

