



s.6400

1/2" - 4" EN 10226-1, ISO 5211



Quality

- 24h 100% seal test guaranteed
- Dual sealing system allows valve to be operated in either direction making installation easier
- No metal-to-metal moving parts
- No maintenance ever required
- Silicone-free lubricant on all seals
- Chrome plated brass ball for longer life

Body

- Hot forged sand blasted, nickel plated brass body and cap sealed with Loctite® or equivalent thread sealant
- Integrated ISO 5211 and DIN 3337 mounting flange for universal connection to actuator
- Finest brass according to EN 12165 and EN 12164 specifications

Stem

- Blowout-proof nickel plated brass stem
- Maintenance-free, double FPM O-rings at the stem for maximum safety

Sealing

- Reinforced PTFE self-lubricating seats with flexible-lip and wear compensation design

Threads

- EN 10226-1, ISO 228 parallel female by female threads

Flow

- 100% full port for maximum flow

Operating mechanism

- Integrated sturdy ISO 5211 flange allows direct mounting of electric and pneumatic actuators, with no bracket or coupling required. See **RuB** line of electric and pneumatic actuators.

Working pressure & temperature

- 40 bar (600 PSI) up to 2", 30 bar (450 PSI) over 2" non-shock cold working pressure
- For use with dangerous fluids pressure rating is 5 bar
- -20°C to +170°C (-4°F to +350°F)
- **WARNING:** freezing of the fluid in the installation may severely damage the valve
- For use with dangerous fluids temperature rating is -20°C +60°C

Options

- s.64 configuration featuring NPT taper ANSI B.1.20.1 female by female threads, unplated body, reinforced seats and brass or stainless stem and ball
- CW511L brass (lead-free and DZR) for drinking water applications with compression ends
- Configuration for use with slurries or liquid bearing abrasive particles
- Rack and pinion pneumatic actuator (spring return or double acting)
- Compact power electric actuator for some sizes
- Manual lockable handle

Upon request

- Custom design

PED directive

- Assessment according to Pressure Equipment Directive 2014/68/UE module B+D by ICIM (0425)

Approved by or in compliance with

- Water Regulations Advisory Scheme (United Kingdom)
- GOST-R (Russia)
- EAC - Declaration of conformity (Russia, Kazakhstan, Belarus)
- RoHS Compliant (EU)

NOTE: approvals apply to specific configurations/sizes only.



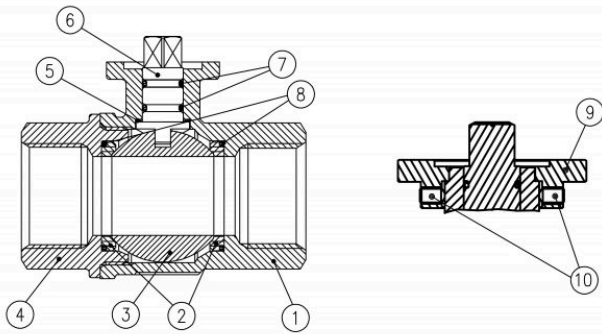

Valves configuration up to 2"

	PART DESCRIPTION	Q.TY	MATERIAL
1	Nickel plated body	1	CW617N
2	Ball seat	2	PTFE graphite filled 15%
3	Chrome plated ball	1	CW617N
4	Nickel plated end-cap	1	CW617N
5	Washer	1	PTFE carbon filled 25%
6	Nickel plated stem O-ring design	1	CW617N
7	O-Ring	2	FPM
8	O-Ring	2	FPM
9	Black anodized flange (only from 2.1/2" to 4")	1	Aluminum
10	Grub Screw (only from 2.1/2" to 4")	2	CB4FF

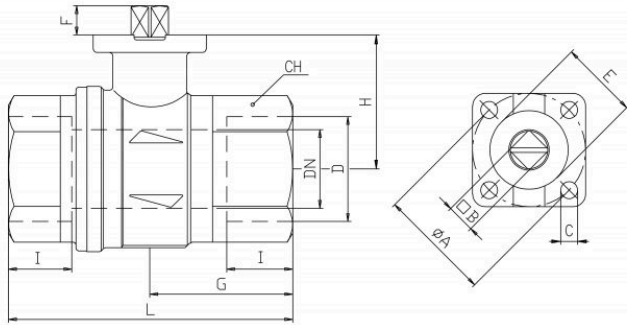

Valve ball seats and stem configuration of valves over 2" is different.

Compliant to CE 2014/68/EU product Equipment category III Module B+D									
Code	S64D00	S64E00	S64F00	S64G00	S64H00	S64I00	S84L00AM	S84M00AM	S84N00AM
D (inch)	1/2	3/4	1	1 1/4	1 1/2	2	2 1/2	3	4
DN(mm)	15	20	25	32	40	50	65	80	100
I (mm)	15.5	18	21	23	24.5	26.5	32	35	41.5
L (mm)	75	80	90	110	120	140	156	177	216
G (mm)	30.5	37	45.5	52	59	67.5	78	88.5	108
H (mm)	31	38.5	42.5	55.5	62	69	89	96	111
CH(mm)	27	32	41	50	55	70	85	99	125
ØA(mm)	36	36	36	50	50	50	70	70	70
□B(mm)	9	9	9	11	11	14	17	17	17
C (mm)	5.6	5.6	5.6	6.6	6.6	6.6	8.5	8.5	8.5
E(mm)	25	25	25	35	35	35	55	55	55
F(mm)	7.5	8.5	8.5	10	10	14.5	18	18	18
Flange connection DIN ISO 5211 DIN 3337	F03	F03	F03	F05	F05	F05	F07	F07	F07
Kv(m ³ /h)	28	60	100	155	245	290	516	770	1120

Ball valves are marked CE on end-cap from 1.1/4" to 4" as follow:
CE 0425 cat IIIB+D PS: 5 GAS TS1:-20°C TS2:+60°C

Torque for actuator sizing N.m

Delta P →	0 ÷ 15 bar		40 bar (30 Bar over 2")	
	To open	To close	To open	To close
Valve size				
1/2"	2,8	1,7	2,8	1,7
3/4"	3,8	2,3	3,8	2,3
1"	7,1	4,2	7,1	4,2
1.1/4"	11,7	12,6	13,6	12,6
1.1/2"	24,9	20,3	30,9	20,3
2"	29,6	25,1	37	25,1
2.1/2"	42	42	105	105
3"	102	102	120	120
4"	186	186	225	225

Torque correction factors

Valve torque can vary according to operating frequency, temperature and friction characteristics of the media.
If media has more or less friction than water, multiply torque by the following factors.

Lubricating oils or liquids	0.8
Dry gases, natural gas	1.5
Slurries or liquids bearing abrasive particles	1.5 ÷ 2.5

Pressure-temperature chart

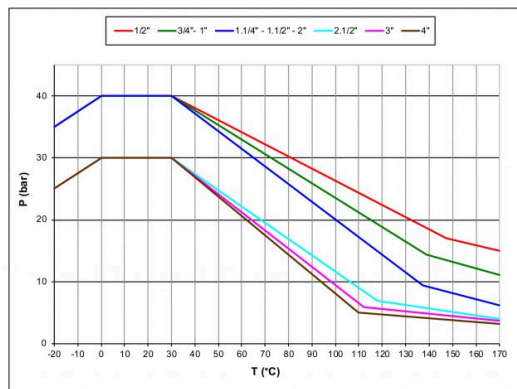

Pressure drop chart

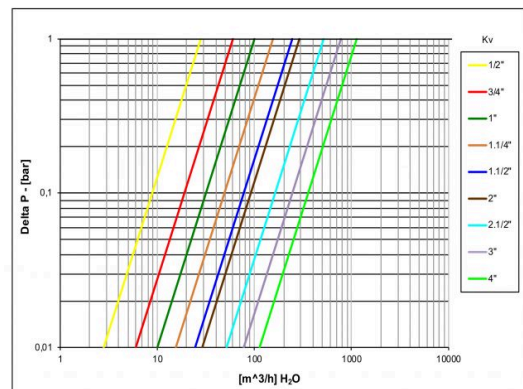

Ask for additional information on the whole range of **RUB** products and consult with your supplier for special applications.
For complete disclaimer: www.rubvalves.com/disclaimer