



s.42

1/2" - 3" solder-ends ball valve



Quality

- 24h 100% seal test guaranteed
- Dual sealing system allows valve to be operated in either direction making installation easier
- No metal-to-metal moving parts
- Handle clearly shows ball position
- Silicone-free lubricant on all seals
- Chrome plated brass ball for longer life
- Handle stops on body to avoid stress at stem

Body

- Hot forged sand blasted, unplated brass body and cap sealed with Loctite® or equivalent thread sealant
- Finest brass according to EN 12165 and EN 12164 specifications

Stem

- Blowout-proof nickel plated brass stem
- Pure PTFE adjustable packing gland and reinforced washer for lower torque and easy maintenance

Sealing

- Pure PTFE self-lubricating seats with flexible-lip design

Connections

- Solder end female by female connections



Flow

- Full port to DIN 3357 for maximum flow

Handle

- Geomet® carbon steel handle with thick PVC dip coating. Handle coating offers both thermal and electrical protection
- **WARNING:** do not exceed reasonable temperature and/or electrical load

Working pressure & temperature

- 600 PSI (40 bar) up to 2", 450 PSI (30 bar) over 2", (150 WSP / -10 bar all sizes) non-shock cold working pressure
- **NOTE:** for solder joints ratings see Table 1 on reverse
- 250 PSI (17 bar) non-shock working pressure for LP-Gas
- *150 psig (10 bar) non-shock working steam pressure. Not suitable for throttling steam.
- -4°F to +366°F (-20°C to + 170 °C) (for solder joints ratings see Table 1 on reverse)
- **WARNING:** freezing of the fluid in the installation may severely damage the valve

Options up to 2" size

- Stem extension (assemble after soldering)
- Lead free for safe drinking water (0.25% or less Pb)
- Oval lockable handle up to 2", round over 2"
- Patented locking device for valves up to 3"
- T-handle
- Stubby handle

Upon request

- Stainless steel ball and/or stem (1.4401 / AISI 316)
- Glass filled PTFE seals
- Stainless steel handle (1.4016 / AISI 430)
- Custom design

Approved by or in compliance with

GOST-R (Russia)
 RoHS Compliant (EU)
 Underwriters Laboratories (United States, Canada):
 - Guide YSDT: LP-Gas shut-off valve
 - Guide YRBX: Flammable liquid shut-off valve
 - Guide YRPV: Gas shut-off valve for use with natural and manufactured gases
 - Guide MHKZ: No. 6 oil at 250°F
 Meeting WW-V-35C Federal U.S. Specification (United States)
 CRN-TSSA acc. to MSS SP110 (Canada)
NOTE: approvals apply to specific configurations/sizes only.

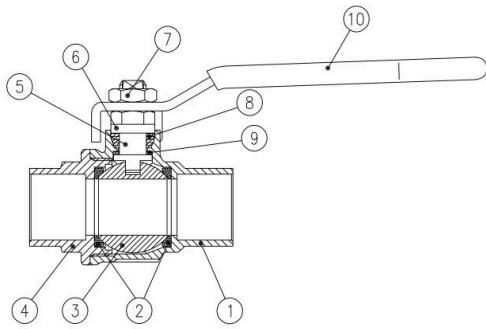

	PART DESCRIPTION	Q.TY	MATERIAL
1	Unplated solder end body	1	CW617N
2	Seat	2	PTFE
3	Chrome plated ball	1	CW617N
4	Unplated solder end-cap	1	CW617N
5	Nickel plated stem packing gland design	1	CW617N
6	Nickel plated gland nut	1	CW617N
7	Geomet® nut	1	CB4FF (EN10263-2)
8	Packing gland seal	1	PTFE
9	Washer	1	PTFE carbon filled 25%
10	Yellow PVC coated Geomet® steel handle	1	DD11 (EN10111)

1.1/4" - 2" hollow ball

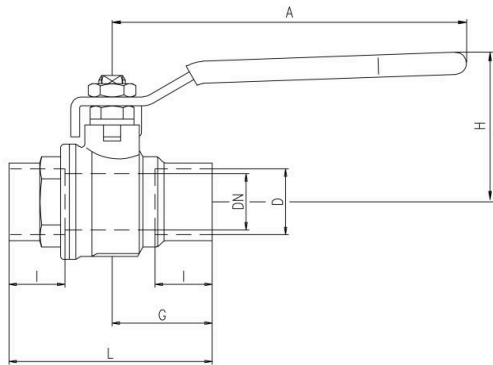

Code	S42D00	S42E00	S42F00	S42G00	S42H00	S42I00	S42L00	S42M00	
D (inch)	Nominal	1/2	3/4	1	1 1/4	1 1/2	2	2 1/2	3
	actual	0.6271	0.8771	1.1279	1.3779	1.6279	2.1279	2.628	3.128
DN (inch)	0.590	0.787	0.984	1.259	1.574	1.968	2.559	3.149	
I (inch)	0.492	0.748	0.905	0.964	1.102	1.338	1.476	1.673	
L (inch)	2.244	2.854	3.346	3.819	4.488	5.433	6.614	7.598	
G (inch)	1.181	1.476	1.673	1.909	2.244	2.716	3.307	3.799	
A (inch)	3.937	4.724	4.724	6.220	6.220	6.220	10.039	10.039	
H (inch)	1.695	1.988	2.153	2.988	3.236	3.500	5.196	5.511	
Cv (GPM)	32.3	48.5	80.9	92.4	144.4	206.8	596.2	896.5	

Joining material	Melting range degrees		Working temperature degrees		Maximum working gauge pressure					
					Size 1/8" - 1"		Size 1 1/4" - 2"		Size 2 1/2" - 4"	
					psi	kPa	psi	kPa	psi	kPa
50-50 tin-lead solder* ASTM B32 alloy grade 50 A	361/421	185/215	0/+100	-18/+38	200	1400	176	1200	150	1050
			0/+150	-18/+66	150	1050	125	850	100	700
			0/+200	-18/+93	100	700	90	600	75	500
			0/+250	-18/+121	85	600	75	500	50	350
95-5 tin-antimony solder ASTM B32 alloy grade 95TA	450/464	230/240	0/+100	-18/+38	500**	3500**	400**	2800**	300**	2100**
			0/+150	-18/+66	400**	2800**	350**	2400**	275**	2000**
			0/+200	-18/+93	300**	2100**	250**	1700**	200	1400
			0/+250	-18/+121	200	1400	175	1200	150	1050

Note:

Above stated limits are not imposed by the valve, but by the strength of the soldering joint according to ASME B16.22.

* This alloy contains more than 0,2% lead and, according to certain specifications, cannot be used for potable water or other foods.

** Soldered copper tube joints have been tested at 230 psi (1600 kPa) in accordance with ISO 2016

Pressure-temperature chart

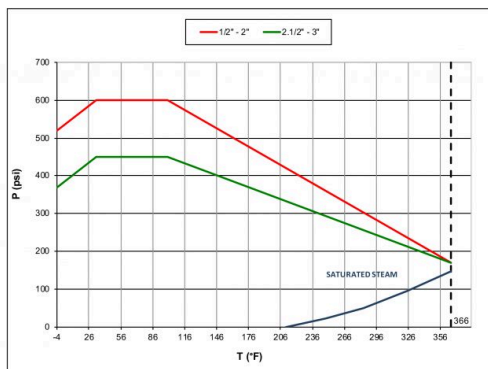

Chart applies to valve, not to solder joints

Pressure drop chart

